

SANYO

LC Colour Projector

**MODEL PLC-250PB
PLC-250PP**

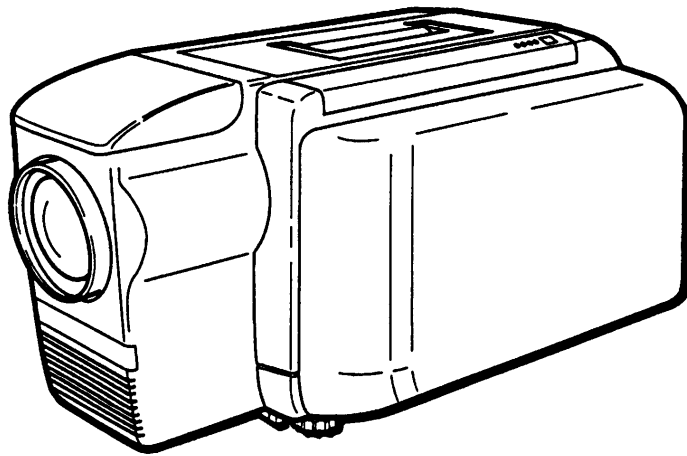

OWNER'S INSTRUCTION MANUAL

TABLE OF CONTENTS

	PAGE
1. SAFETY PRECAUTIONS	3
2. FEATURES	3
3. IMPORTANT SAFETY INSTRUCTIONS	4
4. DESCRIPTION	5
5. OPERATION OF CONTROLS	6-7
6. REMOTE CONTROL OPERATION	8-9
7. SETTING-UP THE PROJECTOR	10
8. USING THE PROJECTOR	11-14
9. PICTURE AND SOUND ADJUSTMENTS	14-15
10. CONNECTING THE PROJECTOR	16-17
11. AIR FILTER CARE AND CLEANING	18
12. LAMP REPLACEMENT/TEMPERATURE INDICATORS	18
13. TROUBLE-SHOOTING GUIDE	19
14. TECHNICAL SPECIFICATIONS	BACK COVER

IMPORTANT: (UK MODEL ONLY)

This cord is already fitted with a moulded plug incorporating a fuse, the value of which is indicated on the pin face of the plug. Should the fuse need to be replaced, an ASTA approved BS 1362 fuse must be used of the same rating, marked thus . If the fuse cover is detachable, never use the plug with the cover omitted. If a replacement fuse cover is required, ensure it is of the same colour as that visible on the pin face of the plug (i.e. red or orange). Fuse covers are available from the Parts Department indicated in your User Instructions.

If the plug supplied is not suitable for your socket outlet, it should be cut off and destroyed.

The end of the flexible cord should be suitably prepared and the correct plug fitted.

WARNING: A PLUG WITH BARED FLEXIBLE CORDS IS HAZARDOUS IF ENGAGED IN A LIVE SOCKET OUTLET.

The Wires in this mains lead are coloured in accordance with the following code:

BlueNeutral

Brown.....Live

As these colours may not correspond with the coloured markings identifying the terminals in your plug, proceed as follows:

The wire which is coloured Blue must be connected to the terminal in the plug which is marked with the letter N or coloured Blue or Black. The wire which is coloured Brown must be connected to the terminal which is marked with the letter L or coloured Brown or Red.

WARNING: DO NOT CONNECT EITHER WIRE TO THE EARTH TERMINAL WHICH IS MARKED WITH THE LETTER E. BY THE EARTH SYMBOL  OR COLOURED GREEN OR GREEN/YELLOW.

1 SAFETY PRECAUTIONS

WARNING:

TO REDUCE THE RISK OF FIRE OR ELECTRIC SHOCK, DO NOT EXPOSE THIS APPLIANCE TO RAIN OR MOISTURE.

Intense light source. Do not stare directly into the projection lens as possible eye damage could result. Be especially careful that children do not stare directly into the light beam.

If the LC colour projector will not be used for an extended time, unplug the LC colour projector from the power outlet.

READ AND KEEP THIS OWNER'S INSTRUCTION MANUAL FOR LATER USE.

IMPORTANT:

For your protection in the event of theft or loss of this LC colour projector, please record the Model Number and Serial Number located on the rear of unit and retain this information. Refer to these numbers whenever you call upon your authorized distributor regarding this product.

Model No: _____

Serial No: _____

2 FEATURES

- 4 colour system, PAL, SECAM, NTSC4.43, NTSC compatible.
- 3-LCD projection system realizes 762cm (300-inch) big screen size with a sharper and clearer picture.
- High-quality 7.6cm (2.98-inch) twin-TFT LCD panel.
- Screen size is adjustable from 20 inches to 300 inches.
- Can be projected directly onto a white screen or white wall.
- 112,800 pixels per panel promises high resolution.
- Keystone correction, convenient for the ceiling or floor mount projection in short distance.
- Motor-drive ZOOM and FOCUS.
- Lit-up remote control.
- Lighted control panel for easy operation.
- SCART, S-VIDEO terminals provided.
- Audio monitor output terminal provided for the external sound system.
- Built-in Audio amplifier and speaker (monaural).
- Superimpose, Blue Back and Reverse Picture Scanning feature provided.

3 IMPORTANT SAFETY INSTRUCTIONS

All the safety and operating instructions should be read before the product is operated.

Read all of the instructions given here and retain them for later use. Unplug this projector from AC power supply before cleaning. Do not use liquid or aerosol cleaners. Use a damp cloth for cleaning.

Do not use attachments not recommended by the manufacturer as they may cause hazards.

Do not place this projector on an unstable cart, stand, or table. The projector may fall, causing serious injury to a child or adult, and serious damage to the projector. Use only with a cart or stand recommended by the manufacturer, or sold with the projector. Wall or shelf mounting should follow the manufacturer's instructions, and should use a mounting kit approved by the manufacturer.

Do not expose this unit to rain or use near water... for example, in a wet basement, near a swimming pool or the like.

Slots and openings in the cabinet and the back or bottom are provided for ventilation, to insure reliable operation of the equipment and to protect it from overheating.

The openings should never be covered with cloth or other material, and the bottom opening should not be blocked by placing the projector on a bed, sofa, rug, or other similar surface. This projector should never be placed near or over a radiator or heat register.

This projector should not be placed in a built-in installation such as a bookcase unless proper ventilation is provided.

This projector should be operated only from the type of power source indicated on the marking label. If you are not sure of the type of power supplied, consult your authorized distributor or local power company.

Do not overload wall outlets and extension cords as this can result in fire or electric shock. Do not allow anything to rest on the power cord. Do not locate this projector where the cord will be abused by persons walking on it.

Never push objects of any kind into this projector through cabinet slots as they may touch dangerous voltage points or short out parts that could result in a fire or electric shock. Never spill liquid of any kind on the projector.

Do not attempt to service this projector yourself as opening or removing covers may expose you to dangerous voltage or other hazards. Refer all servicing to qualified service personnel.

Unplug this projector from wall outlet and refer servicing to qualified service personnel under the following conditions:

- When the power cord or plug is damaged or frayed.
- If liquid has been spilled into the projector.
- If the projector has been exposed to rain or water.
- If the projector does not operate normally by following the operating instructions. Adjust only those controls that are covered by the operating instructions as improper adjustment of other controls may result in damage and will often require extensive work by a qualified technician to restore the projector to normal operation.
- If the projector has been dropped or the cabinet has been damaged.
- When the projector exhibits a distinct change in performance-this indicates a need for service.

When replacement parts are required, be sure the service technician has used replacement parts specified by the manufacturer that have the same characteristics as the original part. Unauthorized substitutions may result in fire, electric shock, or injury to persons.

Upon completion of any service or repairs to this projector, ask the service technician to perform routine safety checks to determine that the projector is in safe operating condition.

Follow all warnings and instructions marked on the projectors.

For added protection for the projector during a lightning storm, or when it is left unattended and unused for long periods of time, unplug it from the wall outlet. This will prevent damage due to lightning and powerline surges.



An appliance and cart combination should be moved with care. Quick stops, excessive force, and uneven surfaces may cause the appliance and cart combination to overturn.

If the projector is to be built into a compartment or similarly enclosed, the minimum distances must be maintained.

Do not cover the ventilation slot on the projector. Heat build-up can reduce the service life of your projector, and can also be dangerous.

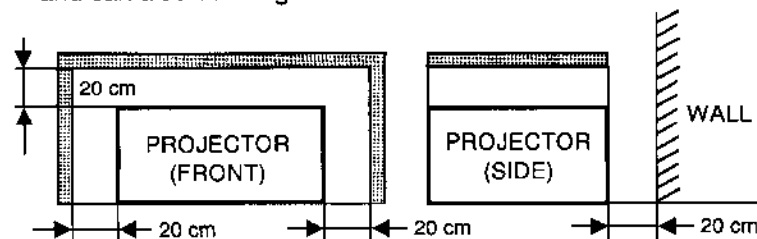

4 DESCRIPTION

FRONT

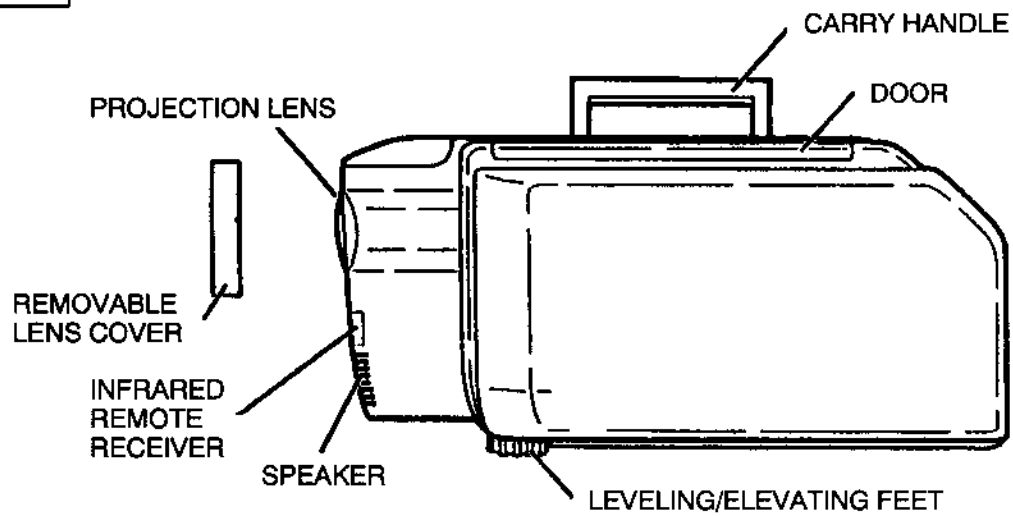

REAR

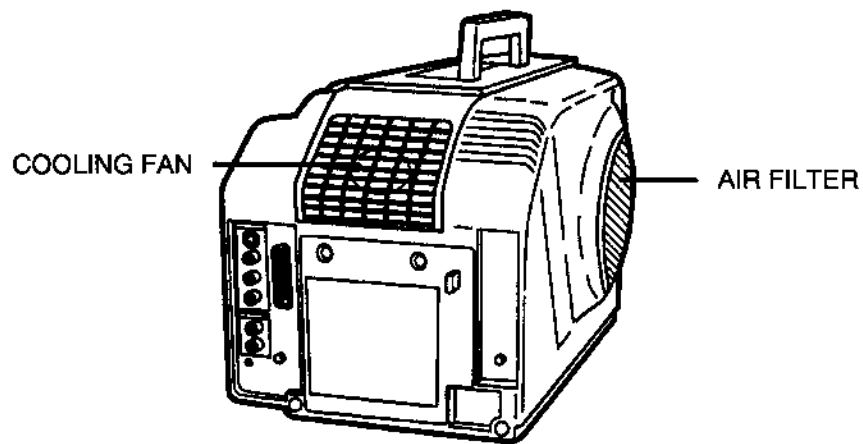

Connect the AC power supply cord (supplied) to the projector

MOVING THE PROJECTOR

Use the carry handle when moving the projector.

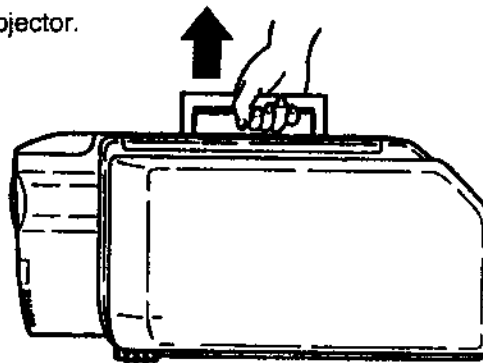

Replace the lens cover when moving the projector to prevent damage to the lens.

5 OPERATION OF CONTROLS

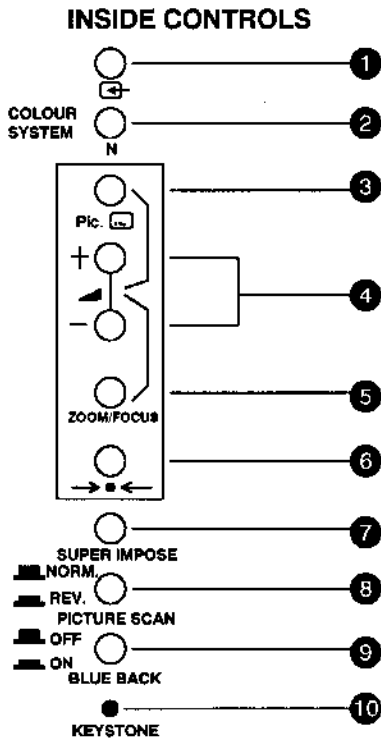
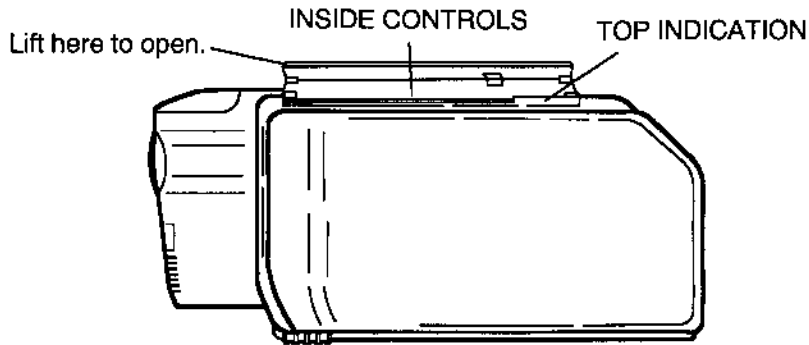

TOP INDICATION

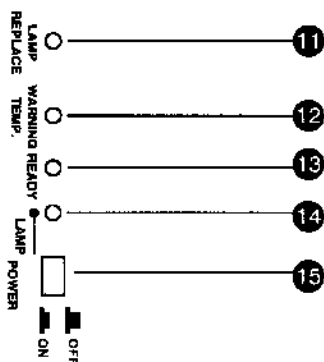

- 1 **VIDEO MODE BUTTON**
Press to select video source. (Video Input-1, Video Input-2, or RGB INPUT)
- 2 **COLOUR SYSTEM SELECT BUTTON**
Press to select colour system. (AUTO → PAL → SECAM → NTSC4.43 → NTSC)
- 3 **FUNCTION SELECT BUTTON**
Used to select on-screen adjustment displays for colour, tint, brightness, contrast, sharpness and sound. Press repeatedly to cycle.
- 4 **LEVEL CONTROL BUTTONS**
Used to adjust volume, zoom, focus, colour, tint, brightness, contrast, sharpness and keystone by pressing + or - button.
- 5 **ZOOM/FOCUS BUTTON**
Used to select power zoom lens or focus system.
- 6 **NORMALIZATION BUTTON**
Used to reset to normal factory set picture and sound adjustment.
- 7 **SUPERIMPOSE BUTTON**
Press this button to produce white characters and lines on a blue background.
- 8 **REVERSE PICTURE SCANNING BUTTON**
Automatically reverses the projected screen image.
- 9 **BLUE BACK BUTTON**
Used to project the blue image without video noise on the screen when the video source is unplugged or turned off.
- 10 **KEYSTONE BUTTON**
Used to select the keystone correction mode.
- 11 **LAMP REPLACEMENT INDICATOR**
Lights orange when projection lamp is nearing end of service life.
- 12 **TEMPERATURE WARNING INDICATOR**
Lights red when internal projector temperature is too high.
- 13 **READY INDICATOR**
Lights green when projector is ready to be turned on.
- 14 **POWER INDICATOR**
Lights dim when the projector is on.
Lights bright when the projector is stand-by position.
- 15 **POWER (LAMP) ON/OFF BUTTON**
Press to turn projection lamp on or off.

BACK OF THE PROJECTOR

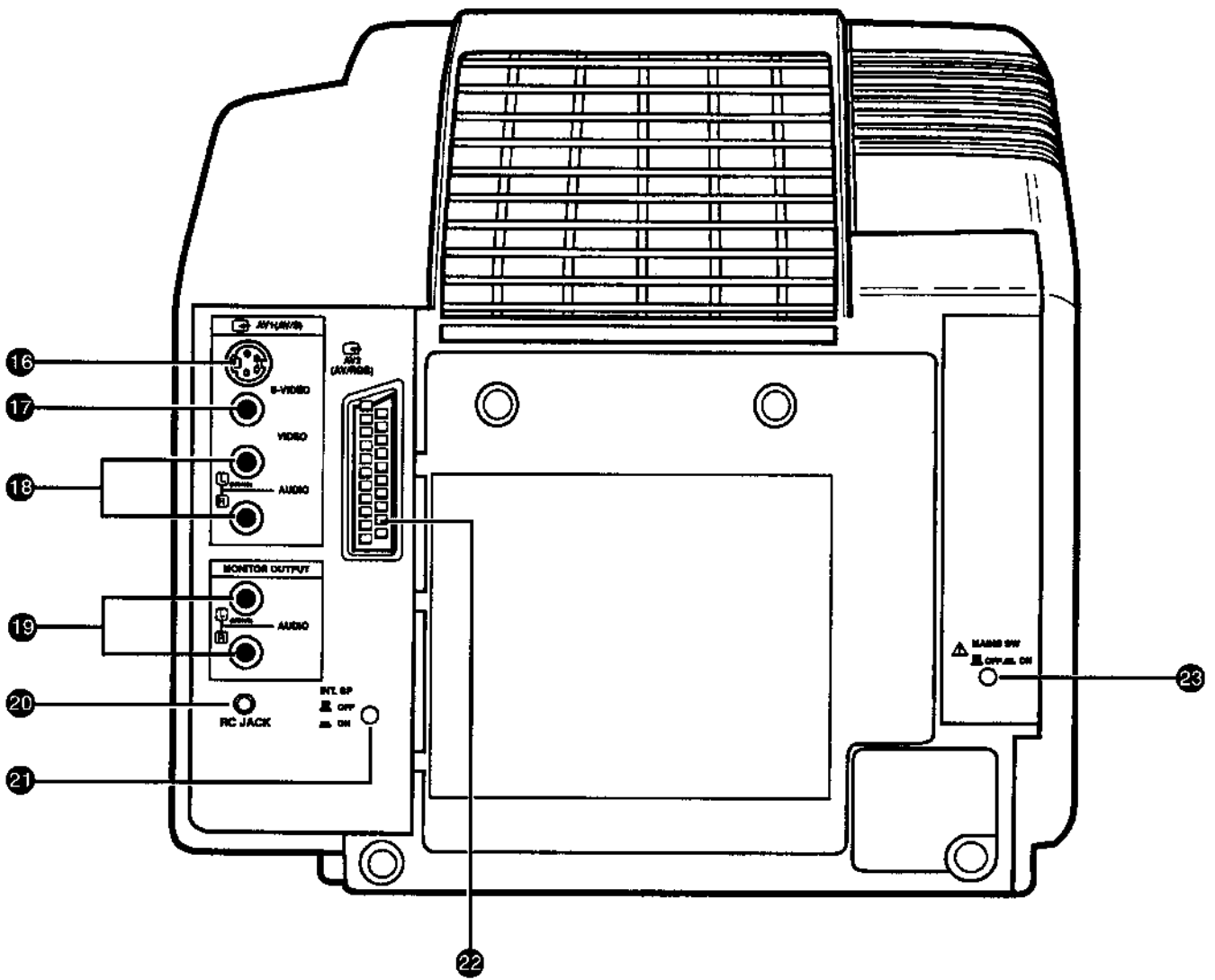

- 16 S-VIDEO INPUT JACK
Used to connect a S-VHS video source to the projector.
- 17 VIDEO INPUT-1 JACK
Used to connect a video source to the projector.
- 18 AUDIO INPUT-1 JACKS
Used to connect an audio input to the projector.
- 19 AUDIO MONITOR OUTPUT JACKS
Permits audio connection to a monitor.
- 20 WIRED REMOTE JACK
When using the wired remote control, connect the remote cable to this jack.
- 21 INT. SP ON/OFF BUTTON
Turns the built-in speaker on or off.
- 22 21-PIN TERMINAL
Used to connect a video source with a 21-pin terminal to the projector.
- 23 MAINS ON/OFF BUTTON
Press to turn the projector on.

6 REMOTE CONTROL OPERATION

INFRARED/ WIRED REMOTE CONTROL

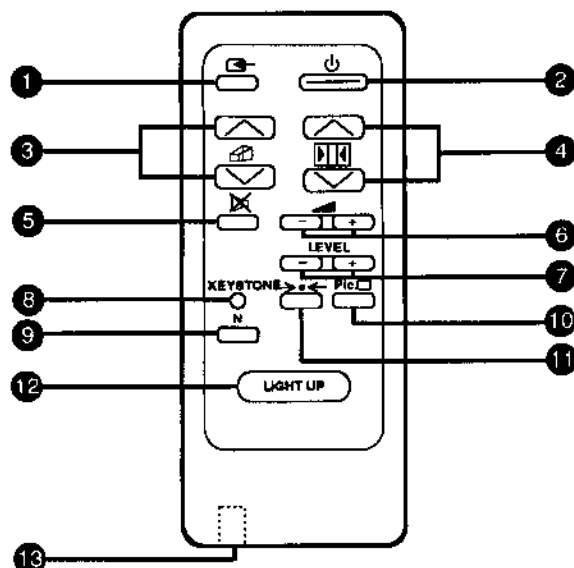

- ① **VIDEO MODE SELECT BUTTON**
Press to select video source. (Video Input-1, Video Input-2 or RGB Input)
- ② **POWER (LAMP) ON/OFF BUTTON**
Press to turn projection lamp on or off.
- ③ **ZOOM BUTTONS**
Used to operate power zoom lens.
- ④ **FOCUS BUTTONS**
Used to operate power focus system.
- ⑤ **SOUND MUTE BUTTON**
Used to mute sound.
- ⑥ **VOLUME BUTTONS**
Used to adjust volume.
- ⑦ **LEVEL CONTROL BUTTONS**
Used to adjust zoom, focus, colour, tint, brightness, contrast, sharpness and keystone by pressing + or - button.
- ⑧ **KEystone BUTTON**
Used to select the keystone correction mode.
- ⑨ **COLOUR SYSTEM SELECT BUTTON**
Press to select ,colour system. (AUTO → PAL → SECAM → NTSC4.43 → NTSC)
- ⑩ **FUNCTION SELECT BUTTON**
Used to select on-screen adjustment displays for colour, tint, brightness, contrast and sharpness.
Press repeatedly to cycle.
- ⑪ **NORMALIZATION BUTTON**
Used to reset to normal factory set picture and sound adjustment.
- ⑫ **LIGHT UP BUTTON**
Press to light the illumination for function buttons on the remote control unit for 5 seconds, and press any other function button during the lighting to light for another 5 seconds.
- ⑬ **WIRED REMOTE JACK**
When using the wired remote control, connect the remote cable to this jack.

REMOTE CONTROL BATTERY INSTALLATION

- 1** Remove the battery compartment lid.

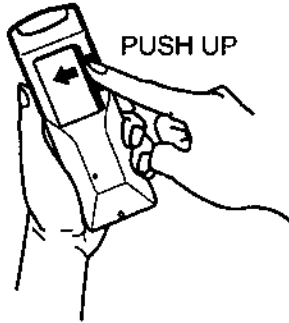

- 2** Slide the batteries into the compartment.

Note: For correct polarity (+ and - terminal), be sure the battery terminals are in contact with the pins in the compartment.

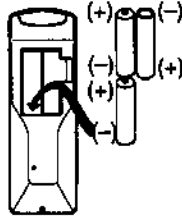

- 3** Replace the compartment lid.

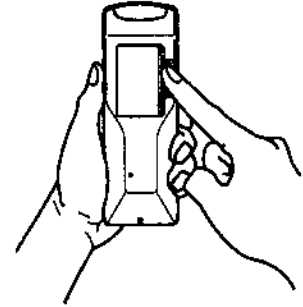

The remote control unit can be used as wireless or wired remote control.

USING THE REMOTE CONTROL UNIT (wireless)

Point the remote control toward the front of the projector (Receiver window) whenever pressing the buttons. Maximum operating range for the remote control is about 5m and 150° from the front of the projector.

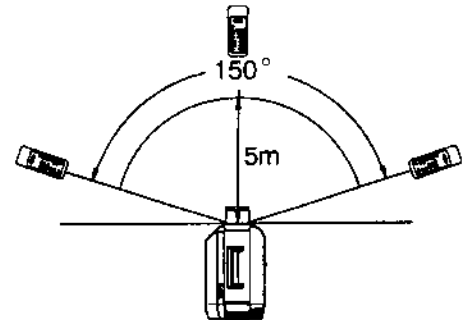

USING THE REMOTE CONTROL UNIT (wired)

Connect a remote control cable to RC jacks located on the remote control unit and the back of the projector.

To insure safe operation, please observe the following precautions:

- * Use (3) AA, UM3 or R06 type batteries.
- * Change three batteries at the same time.
- * Do not use a new battery with a used battery.
- * Avoid contact with water.
- * Do not drop the remote control unit.

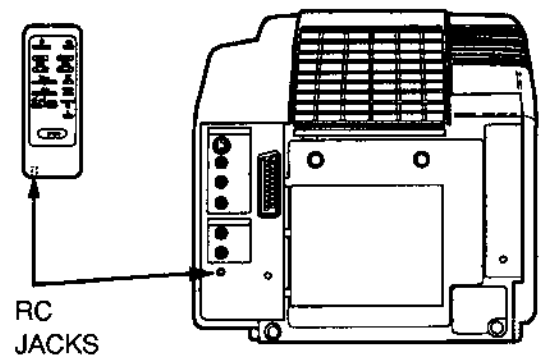

7 SETTING-UP THE PROJECTOR

- POSITIONING:**
- This projector is basically designed to project on a flat projection surface. If the projector is not placed at 90° angle to the screen, the projected image will have a keystone distortion. (See page 14 KEYSTONE CORRECTION.)
 - This projector can be focused from 1.9m ~13.4m.
 - Use the illustration below as an example when positioning the projector to the screen.

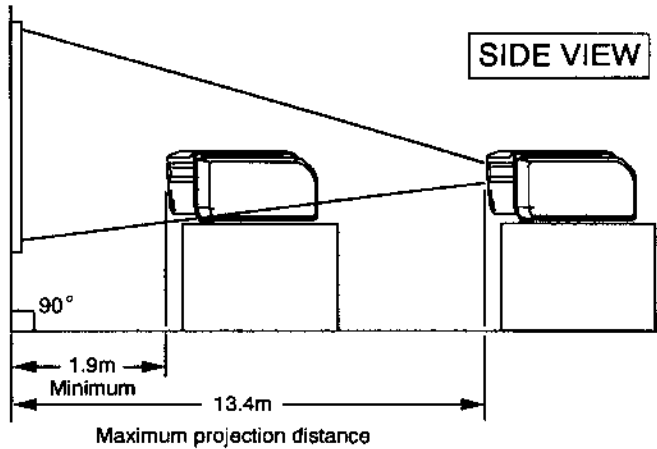

ROOM LIGHT

The projector should ideally be placed in a room with very limited light. Picture quality will be directly affected by lighting conditions.

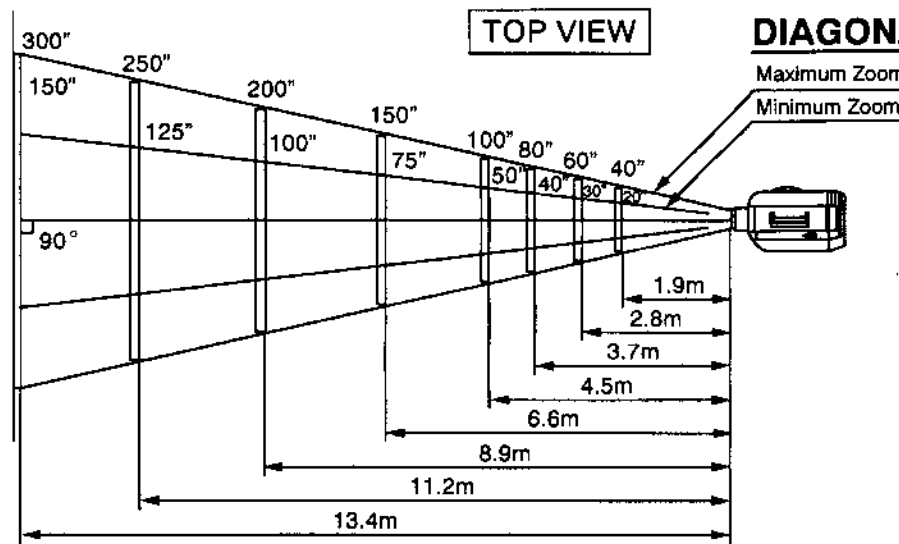

DIAGONAL IMAGE SIZES

LEVELING AND ELEVATING ADJUSTMENTS

Picture adjustments can be made with the two leveling/elevating feet.

Adjustments of 5° up are possible by rotating the feet on the bottom of the projector.

Adjustments of 5° down are possible by raising up the stand.

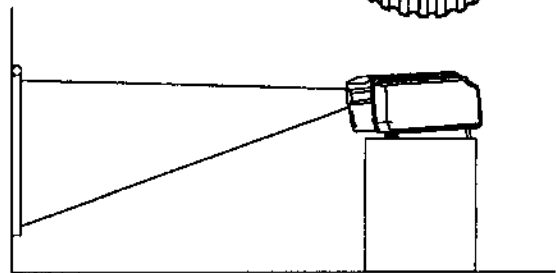
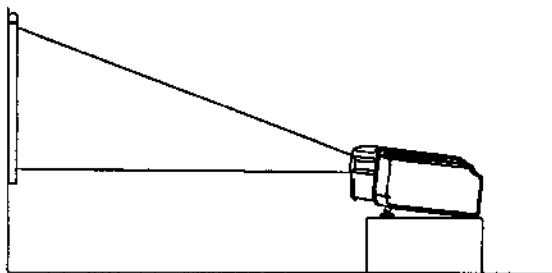
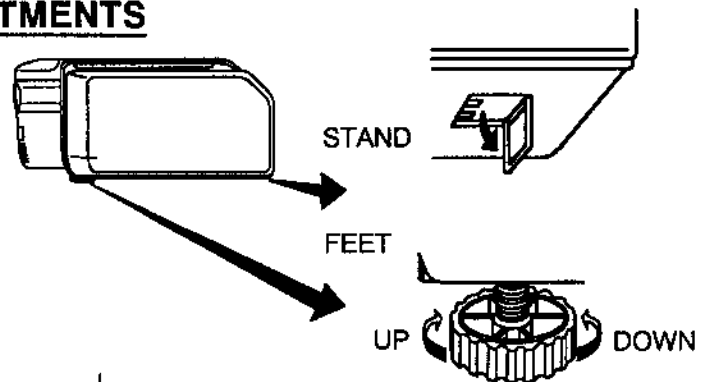

8 USING THE PROJECTOR

TO TURN ON THE PROJECTOR

Connect the projector to a video source (VCR, Video Camera, Video Disc Player, etc.) using the appropriate terminals on the rear of the projector (See page 16-17).

Connect the projector's AC power cord into a wall outlet and press the MAINS ON/OFF button (locate on projector.). The READY indicator will light GREEN.

Press the POWER (LAMP) ON/OFF button **on the projector** to ON. The POWER indicator will light dim and the cooling fan will operate. The wait display (A MOMENT!/UN MOMENTO! and numeral 30) appears on the screen and the count-down starts (30-29-28-...1). The signal from the video source appears after 30 seconds. Now the remote control unit can be activated, and all functions may be used.

A MOMENT!/UN MOMENTO!
30

CAUTION:

- **THIS PROJECTOR USE A METAL-HALIDE ARC LAMP. IF YOU TURN ON THE LAMP, DO NOT TURN IT OFF FOR AT LEAST 5 MINUTES, SO AS NOT TO SHORTEN ITS LIFE.**
- **DO NOT UNPLUG THE PROJECTOR AND PRESS MAINS ON/OFF BUTTON (LOCATE ON PROJECTOR) TO OFF UNTIL THE COOLING FAN HAS STOPPED OPERATING.**

NOTE 1: After you turn off the projector use the POWER (LAMP) ON/OFF button on the projector or on the remote control unit you must wait one minute before you can turn the projector on again.

NOTE 2: TEMPERATURE WARNING INDICATOR flashes red, the projector will automatically turn off. Wait at least 5 minutes before turning the projector on.

If the TEMPERATURE WARNING INDICATOR continues to flash, follow the procedures below:

- (1). Press POWER (LAMP) ON/OFF button to OFF.
- (2). Check the air filter for dust accumulation.
- (3). Remove dust with vacuum cleaner (See air filter care and cleaning on page 18.)
- (4). Press POWER (LAMP) ON/OFF button to ON.

If the TEMPERATURE WARNING INDICATOR still continues to flash, call your authorized distributor for service.

TO TURN OFF THE PROJECTOR (with the remote control unit)

Press the POWER (LAMP) ON/OFF button on the remote control unit to OFF. The POWER indicator will light bright and READY indicator will turn off. The cooling fan will operate for 1 minute after the projector is turned off. (During this "cooling down" period, the projector can not be turned on.)

After 1 minute, the READY indicator will light green again and the projector may be turned on by pressing the POWER (LAMP) ON/OFF button on the remote control unit.

NOTE: Remote control unit can be activated only when POWER (LAMP) ON/OFF button on the projector is pressed to ON.

TO TURN OFF THE PROJECTOR (without the remote control unit)

Press the POWER (LAMP) ON/OFF button on the projector to OFF. The POWER and READY indicator will turn off. The cooling fan will operate for 1 minute after the projector is turned off. (During this "cooling down" period, the projector can not be turned on.)

After 1 minute, the READY indicator will light green again and the projector may be turned on by pressing the POWER (LAMP) ON/OFF button on the projector.

NOTE: If the projector is turned off by the remote control unit, it can be turned back on without the remote by pressing the POWER (LAMP) ON/OFF button on the projector **twice**.

ADJUST THE PROJECTOR

VIDEO MODE SELECT

Press the VIDEO MODE button (located on projector or remote control unit) to select Video Input-1, Video Input-2 or "RGB" Input. The "AV1", "AV2" or "RGB" display will appear on the screen.

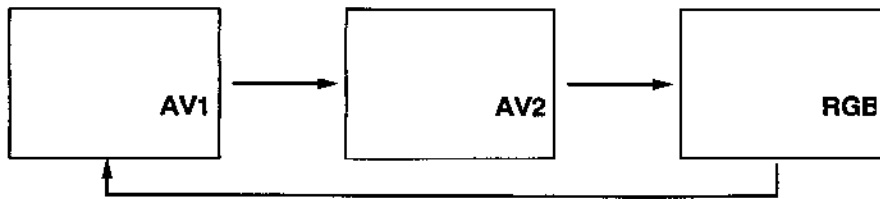

COLOUR SYSTEM SELECT

Press the COLOUR SYSTEM select button (located on projector or remote control unit) to select AUTO, PAL, SECAM, NTSC4.43 or NTSC.

Each time Colour System select button is pressed, the colour system changes as follows:

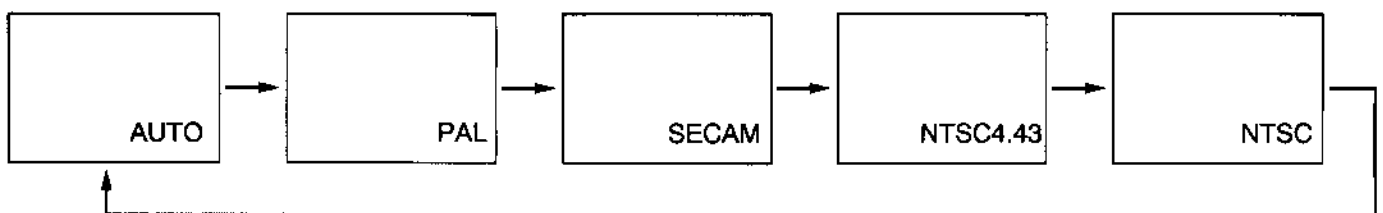

When the colour system is set to "AUTO" position, this projector can receive colour programs from one of the 4 systems (PAL, SECAM, NTSC4.43 or NTSC), automatically.

If the picture quality is poor, make sure the proper colour system is selected to match the video source.

VOLUME ADJUSTMENT

Press INT. SP ON/OFF button to ON(IN) position when the INTERNAL SPEAKER is used.

Press LEVEL buttons on the projector, or VOLUME buttons on the remote control unit to adjust the volume. The screen display will appear.

Pressing (+) will increase volume and the green indicator will increase to the right on the screen.

Pressing (-) will decrease volume and the green indicator will decrease to the left on the screen.

Press INT. SP ON/OFF button to OFF (OUT) position, will disengage the internal speaker on the projector.

SOUND MUTE ADJUSTMENT

Pressing SOUND MUTE button on the remote control unit will mute audio (Sound Mute display will appear). Press SOUND MUTE button again to restore audio to its previous level.

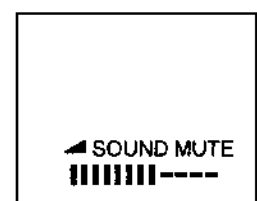
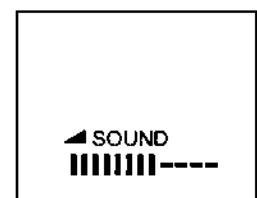

ZOOM ADJUSTMENT (Without remote control unit)

Press ZOOM/FOCUS button until zoom display will appear on the screen, and press LEVEL (+) or (-) to obtain your desired picture size. (The zoom display will appear for 5 seconds.) For the larger size, press (+) and for the smaller size, press (-).

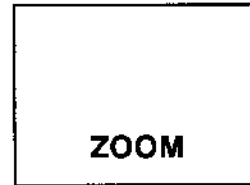

ZOOM ADJUSTMENT (With remote control unit)

Press ZOOM (^) or (v) to obtain your desired picture size. (The zoom display will appear for 5 seconds.) For the larger size, press (^) and for the smaller size, press (v).

FOCUS ADJUSTMENT (Without remote control unit)

Press ZOOM/FOCUS button until focus display will appear on the screen, and press LEVEL (+) or (-) for sharper, crisper picture. (The focus display will appear for 5 seconds.)

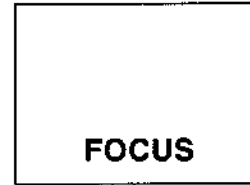

FOCUS ADJUSTMENT (With remote control unit)

Press FOCUS (^) or (v) for sharper, crisper picture. (The focus display will appear for 5 seconds.)

COLOUR AND PICTURE ADJUSTMENT

The normal picture level is factory preset on the projector and can be obtained anytime by pressing the NORMALIZATION button on the projector, or on the remote control unit.

The picture level adjustment can be made by using the FUNCTION and LEVEL buttons on the projector, or on the remote control unit.

OTHER FEATURES

SUPERIMPOSE

Pressing SUPERIMPOSE button on the projector produces white character and lines on a blue background.

BLUE BACK

Pressing BLUE BACK button on the projector to project the blue image without video noise on the screen when the video source is unplugged or turned off.

REVERSE PICTURE SCANNING

The versatile left/right picture reverse capability lets you project onto the screen from in front or behind.

- Press the REVERSE PICTURE SCANNING button on the projector, if required.

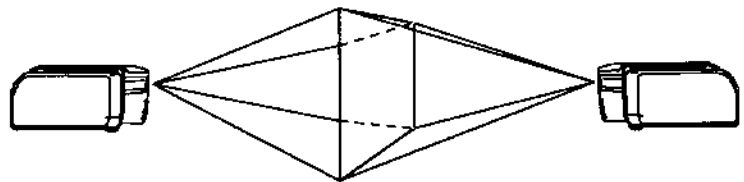

KEYSTONE CORRECTION

When the projector is used at upper or lower position, keystone distortions appear at the bottom or top of the screen. The keystone can be corrected as follows:

● LOW MOUNT PROJECTION

If the projector is mounted low, the keystone will appear at the top of the screen. Press keystone button on the projector, or remote control unit using the tip of a ball-point pen until the bar appears on the top of the screen.

Press the level (-) button until the keystone is corrected.

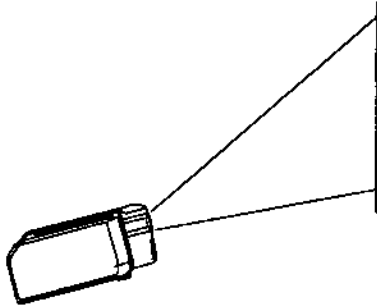

TOP KEYSTONE CORRECTION DISPLAY

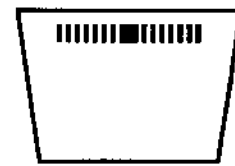

PRESS (-) LEVEL BUTTON

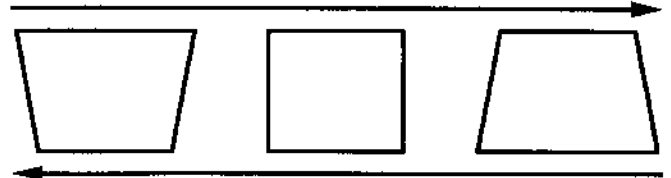

PRESS (+) LEVEL BUTTON

● HIGH MOUNT PROJECTION

If the projector is mounted high, the keystone will appear at the bottom of the screen. Press keystone button on the projector, or remote control unit using the tip of a ball-point pen until the bar appears on the bottom of the screen.

Press the level (-) button until the keystone is corrected.

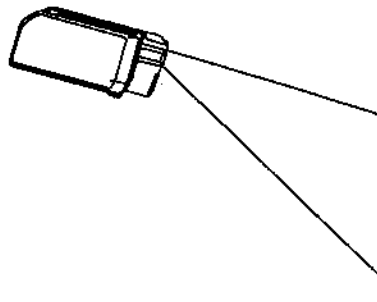

BOTTOM KEYSTONE CORRECTION DISPLAY



PRESS (-) LEVEL BUTTON

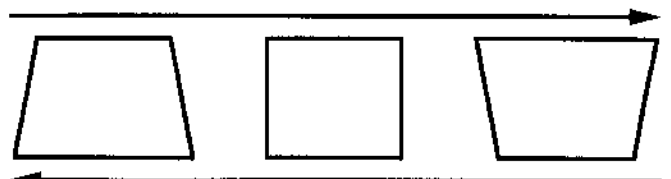

PRESS (+) LEVEL BUTTON

NOTE: The projector is equipped with a built-in memory feature that eliminates the need to readjust the keystone each time the projector is turned off and the AC power cord is disconnected.

9 PICTURE AND SOUND ADJUSTMENTS

INSIDE CONTROLS OF THE PROJECTION

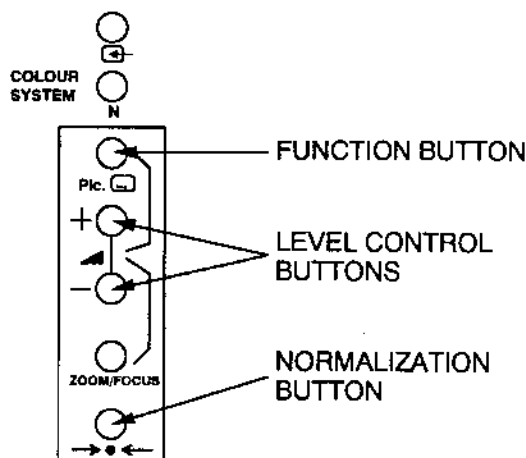

REMOTE CONTROL UNIT

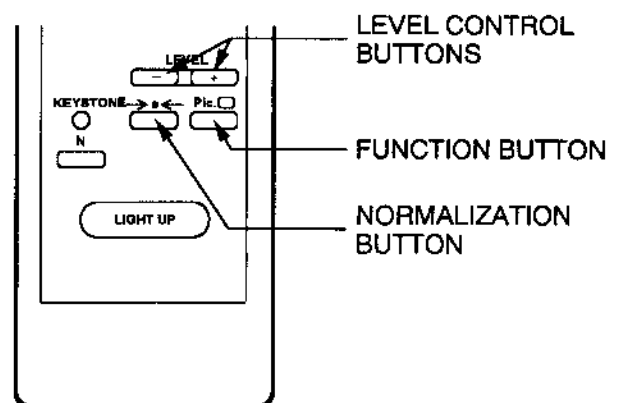

Picture and sound adjustments have been preset at the factory to our quality standards. However, with the FUNCTION and LEVEL buttons on the projector or on the remote control unit you can make picture and sound adjustments you personally prefer.

1. Select the picture and sound adjustments function by pressing FUNCTION button.
Each time FUNCTION button is pressed, the control function changes as follows:

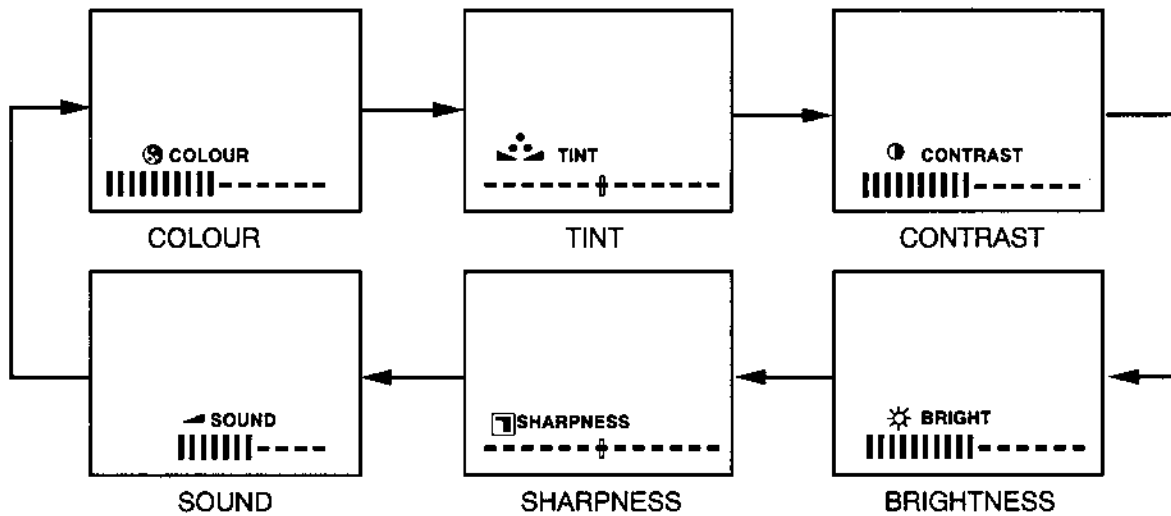

- NOTE:** 1. "SOUND" will be appears, only when FUNCTION button above the projector is pressed.
2. "TINT" will be skipped during in the PAL and SECAM mode.

2. Adjust the colour intensity, tint, contrast, brightness, sharpness or sound by pressing LEVEL (+ and -) buttons.

<ul style="list-style-type: none"> • Press the LEVEL CONTROL buttons to make adjustments. Refer to the control chart below. 	
COLOUR	DECREASES ← → INCREASES
TINT	MORE PURPLE ← → MORE GREEN
CONTRAST	SOFTER ← → SHARPER
BRIGHTNESS	DARKER ← → BRIGHTER
SHARPNESS	SOFTER ← → SHARPER
SOUND	DECREASES ← → INCREASES

3. The ON-SCREEN display will disappear automatically in 8 seconds.

NOTE: The projector is equipped with a built-in memory feature that can maintain the picture and sound level adjustment to set on AV1 and AV2/RGB respectively even if the projector is turned off and AC power cord is disconnected. If NORMALIZATION button is pressed, the projector will return to factory preset level.

10 CONNECTING THE PROJECTOR

Your projector is equipped with various audio/video inputs and outputs including S-VHS video input and 21-pin terminals.

CONNECTING TO THE AV1 INPUT JACKS

Connect to the video and audio outputs of a VCR, video disc player, video camera, satellite TV tuner or other AV equipment.

- If the audio signal from the AV equipment is stereo, be sure to connect the right and left channels to the respective right and left audio input jacks.
- If the external audio signal is monaural, connect it to the left jack.

S-VHS FORMAT VCR CONNECTION

The AV1 input includes an extra video input jack marked S-VIDEO to allow connection to an S-VHS format VCR that has separate Y/C video signals. The S-VIDEO jack has priority over the VIDEO jack.

CONNECTING TO THE AV2 21-PIN TERMINAL

VCR, Video disc player or other AV equipment can be connected to the 21-pin terminal on the rear of the projector. When the 21-pin terminal is used for connection of AV equipment, note the following points.

- When using the equipment with the output function signal into PIN No. 8 of 21-pin terminal below, the VIDEO MODE is automatically set to "AV2" and VIDEO MODE selection is not required. And when using equipment without the output function signal, press VIDEO MODE select button on the projector or remote control to select "AV2" mode.
- When using the equipment with RGB output signal and without the control signals for PIN No. 8 and 16 of 21-pin terminal below, press VIDEO MODE select button to select "RGB" mode, and when using equipment with both RGB output signal and the control signals, the VIDEO MODE is automatically set to "AV2" mode and VIDEO MODE selection is not required.

CONNECTING TO THE AUDIO MONITOR OUTPUT JACK

These jacks will contain the audio information of the selected program source being viewed on the screen. If you have selected program source AV1 the audio signals connected to the AV1 jacks will be available at the audio monitor output jacks.

- If the audio input of the audio equipment is stereo, be sure to connect the right and left channels to the respective right and left jacks.
- If the audio input of the audio equipment is monaural, connect it to the left jack.

Specification of 21-pin terminal

Pin No.	Signal		Pin No.	Signal	
1.	Audio output (right channel)	0.5 Vrms/ \leq 1 K ohm	11.	Green (G) input	0.7 Vp-p /75 ohm
2.	Audio input (right channel)	0.5 Vrms/ \geq 10 K ohm	12.	Not used	_____
3.	Audio output (left channel)	0.5 Vrms/ \leq 1 K ohm	13.	Earth (red)	_____
4.	Earth (audio)	_____	14.	Earth	_____
5.	Earth (blue)	_____	15.	Red (R) input	0.7 Vp-p/75 ohm
6.	Audio input (left channel)	0.5 Vrms/ \geq 10 K ohm	16.	Fast blanking	L: 0-0.4V, H:1-3V
7.	Blue (B) input	0.7 Vp-p 75 ohm	17.	Earth (video)	_____
8.	Function switching	L: 0-2V, H-12V	18.	Earth	_____
9.	Earth (green)	_____	19.	Video sync. output	1 Vp-p/75 ohm
10.	Not used	_____	20.	Video sync. input	1 Vp-p/75 ohm
			21.	Earth	_____

21-PIN TERMINAL

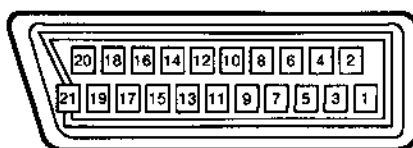

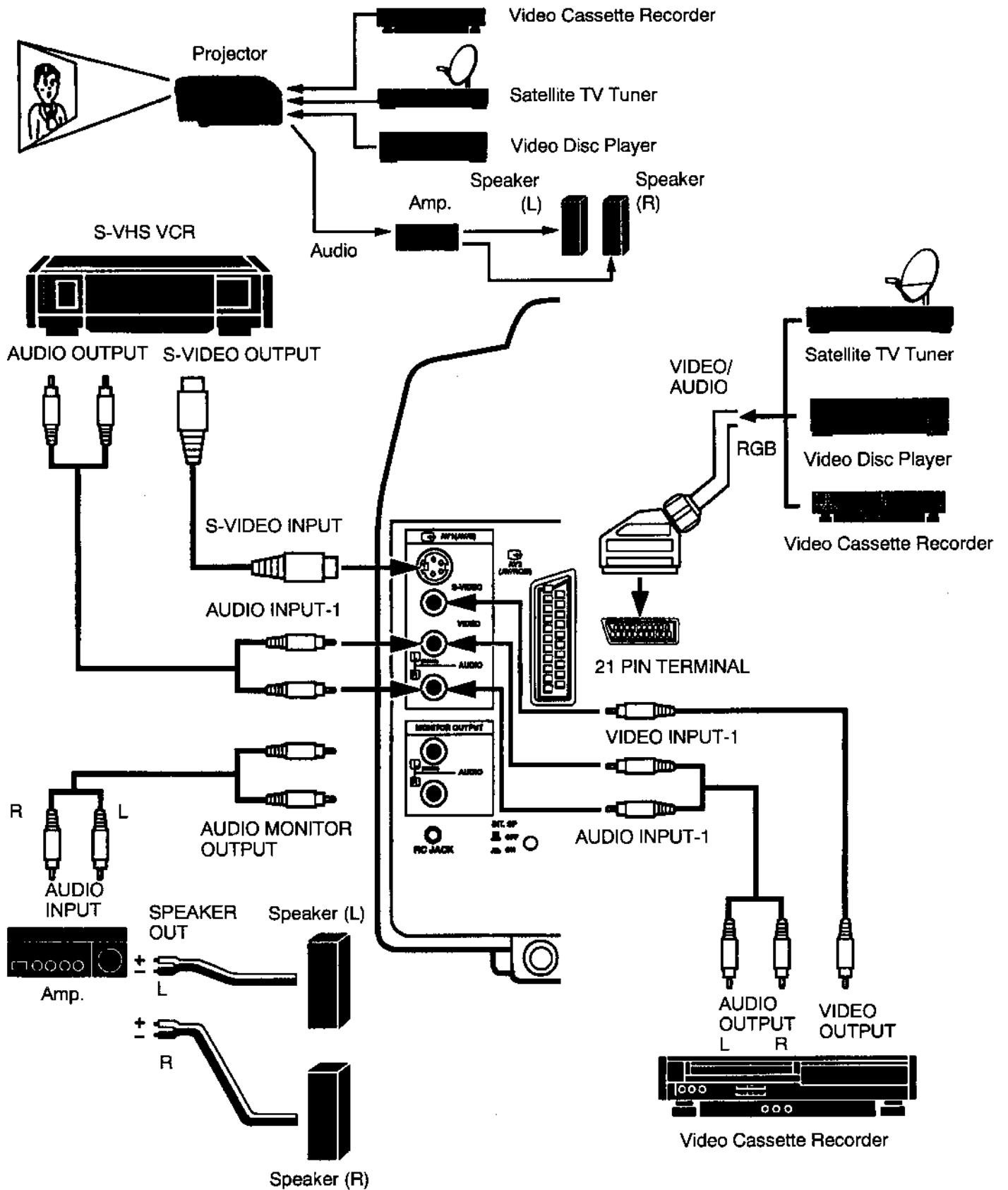

11 AIR FILTER CARE AND CLEANING

The removable air filter prevents dust from accumulating on the surface of the projection lens and projection mirror. Should the air filter become clogged with dust particles, it will reduce the cooling fan's effectiveness and may result in internal heat built up and reduced the life of the projection lamp.

To clean the air filter, follow the cleaning procedures below:

1. Turn the POWER (LAMP) ON/OFF button OFF.
2. Remove the air filter cover from the side of the projector.
3. Remove the air filter and sponge from the filter cover.
4. Clean the air filter and sponge with a vacuum cleaner.
5. Replace the air filter and sponge. Make sure that air filter cover is fully inserted.



Do not clean with water. Doing so may damage the air filter.
Do not operate the projector with air filter removed.

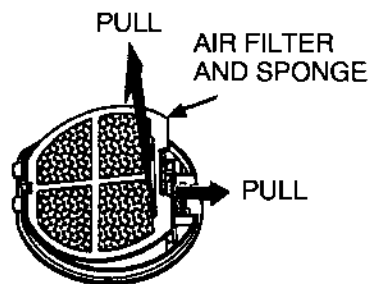
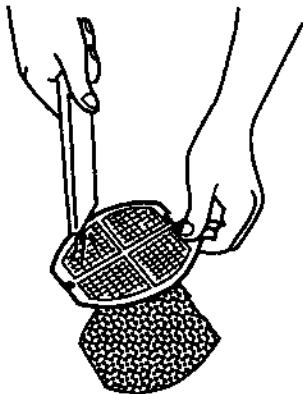
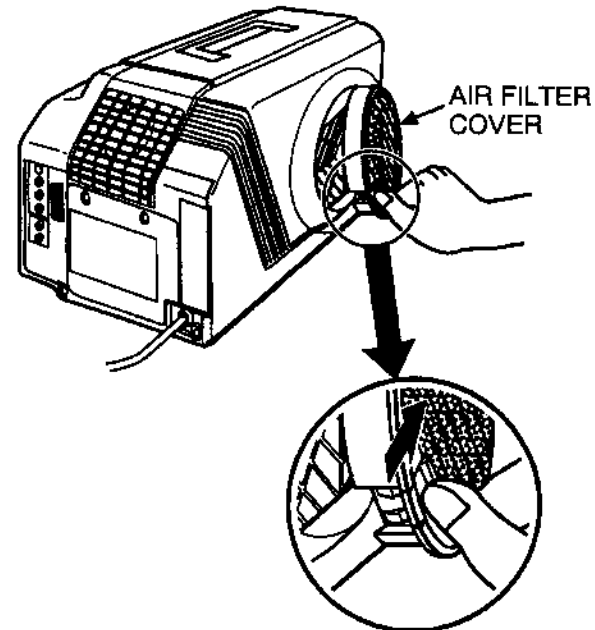

RECOMMENDATION

TO ENJOY PICTURE IMAGE, USE THE PROJECTOR IN THE CLEAN ENVIRONMENT. USAGE IN THE CLEAN ENVIRONMENT IS RECOMMENDED.

When used under the dusty or smoky conditions, dust may accumulate on the liquid crystal panel and lens inside it, and may resultantly be projected on the screen together with the picture.

When the above symptoms are noticed contact the place where your purchased or the nearest service center for the cleaning.

12 LAMP REPLACEMENT & TEMPERATURE WARNING INDICATORS

LAMP REPLACEMENT INDICATOR

When the lamp nears the end of its service life, the picture quality and colour quality will deteriorate and the lamp replacement indicator will light orange.



DO NOT ATTEMPT TO REMOVE OR CHANGE THE PROJECTION LAMP. THE LAMP CAN ONLY BE CHANGED BY QUALIFIED SERVICE PERSONNEL.

TEMPERATURE WARNING INDICATOR

The TEMPERATURE WARNING INDICATOR lights red when the internal temperature of the projector exceeds the normal temperature.

Possible causes for the temperature warning may be:

1. Ventilation slots at the rear or bottom of the projector are blocked. In such an event, reposition the projector so that ventilation slots are not obstructed.
2. Air filter is clogged with dust particles. Remove dust from the air filter by following instructions in the Air Filter Care and Cleaning section above.
If temperature warning indicator remains on after performing the checks listed above, cooling fan/internal circuits may be malfunctioning. Request service from an authorized distributor or service station.

13 TROUBLE SHOOTING GUIDE

Please perform these simple checks before calling for service.

SYMPTOMS	PROCEDURES
No power	<ul style="list-style-type: none"> ● Plug the projector into an AC outlet. ● Press the MAINS ON/OFF button to ON. ● Press the POWER (LAMP) ON/OFF button to ON. ● Check the READY INDICATOR light ON. ● One minute has not passed since LCD projector turned OFF. <p>NOTE: After pressing the POWER (LAMP) ON/OFF button to OFF the projector, the projector functions as follows.</p> <ol style="list-style-type: none"> 1. The POWER and READY indicator will turn off. 2. The cooling fan will operate for 1 minute after the projector is turned off. (During this "cooling down period, the projector can not be turned on.) 3. After 1 minute, the READY indicator will light green again and the projector may be turned on by pressing the POWER (LAMP) ON/OFF button on the projector or on the remote control unit.
No sound from built-in speaker	<ul style="list-style-type: none"> ● Press the VOLUME (▲) and (▼) to (▲). ● Press the INT. SP ON/OFF button to ON. ● Check audio cable connection from audio input source.
Picture is reversed	<ul style="list-style-type: none"> ● Press the REVERSE PICTURE SCANNING button.
Picture blurred or colour faded	<ul style="list-style-type: none"> ● Check the projection distance (1.9m~13.4m). ● Adjust the FOCUS control. <p>NOTE: Moving the projector from a cool temperature location to a warm temperature location may result moisture condensation on the lens. In such an event, leave the projector OFF and wait until condensation disappears.</p>

14 TECHNICAL SPECIFICATIONS

SPECIFICATIONS

Projector Type	Portable LC colour projector
Dimensions (H x W x D)	253 mm × 268 mm × 550 mm
Net Weight	13.6 kg (29.9 lbs)
LCD Panel System	2.98" TFT Active Matrix type (Thin Film Transistor) × 3
Number of Pixels	338,400 (112,800 × 3)
Colour System	4 colour system (PAL, SECAM, NTSC4.43 and NTSC)
Projection Image Size (Diagonal)	51 cm to 762 cm (20 to 300 inch) adjustable
Contrast Ratio	100 :1
Horizontal Resolution	450 TV lines
Projection Lens	f4.2~ 4.5 lens with 135mm ~ 270 mm Motor-drive zoom and focus
Lens Aperture	67 mm
Throw Distance	1.9 m~13.4 m
Projection Lamp	Metal Halide, 200 watt type
Projection Mirror	Dichroic mirror system
AV Input jacks	PHONO Type × 1 (Video, Audio R and L), DIN 4 pin (S-Video) × 1 and 21 pin (SCART) × 1
Audio Monitor Output Jacks	PHONO Type × 1 (R and L)
Built-in Speaker	3W RMS
Image Elevation Adjustment	Up 5° , Down 5°
Voltage	220 ~ 240V AC, 50/60 Hz
Power Consumption	260 Watts
Operating Temperature	5°C ~ 35°C
Storage Temperature	- 10°C ~ 60°C
Remote Control Battery	AA, UM3 or R06 type × 3
Standard Accessories	Remote Control Unit, R/C Cable (1.5m), AC Cord Owner's Instruction Manual, Protective Dust Cover

The SANYO logo is displayed in a bold, black, sans-serif font. The letters 'S', 'A', and 'N' are connected, as are 'Y', 'O', and 'O'. The 'Y' and 'O's have a distinctive design with multiple parallel vertical lines running through them, creating a textured or 'hatched' effect.