

NEC

NEC Technologies, Inc.

1250 N. Arlington Heights Road, Suite 500
Itasca, Illinois 60143-1248

Part No. 78406832
Printed in Japan

NEC Multimedia Theatre

NEC Multimedia Theatre

MultiSync[®] MT 600

LCD Projector
User's Manual

NEC

Precautions

Please read this manual carefully before using your NEC MultiSync MT600 LCD Projector and keep the manual handy for future reference.

Your serial number is located on the side of your MultiSync MT600, below the cooling fan vent. Record it here:

CAUTION

RISK OF ELECTRIC SHOCK DO NOT OPEN

CAUTION

TO PREVENT SHOCK, DO NOT OPEN THE CABINET. NO USER-SERVICEABLE PARTS INSIDE. REFER SERVICING TO QUALIFIED NEC SERVICE PERSONNEL.



This symbol warns the user that uninsulated voltage within the unit may be sufficient to cause electrical shock. Therefore, it is dangerous to make any kind of contact with any part inside of the unit.



This symbol alerts the user that important information concerning the operation and maintenance of this unit has been provided. The information should be read carefully to avoid problems.

Cable Connection

Communication Protocol

Baud rate:	9600 bps
Data length:	8 bits
Parity:	no parity
Stop bit:	one bit
X on/off:	none
Communications procedure:	half duplex

If the CPU of the LCD projector has received the data correctly, it returns an ACK(C5H). If the received data is not correct, the CPU returns a NAK(CAH), then the following status:

Receiving success:	C5
Receiving failure:	CA Err
Err 01:	Command not supported
Err 02:	Checksum error
Err 03:	Command not acceptable(Busy)
Err 04:	Parameter error

NOTE: If failing in powering-on, the CPU returns the following NAKs:

CA Err 1

Err 1 8X (Apply the corresponding bit.)

- Bit 0: Filter cover is not attached correctly
- Bit 1: Lam1p house cover is not not attached correctly
- Bit 2: Overheated
- Bit 3: Lamp lighting failure

PC Control Connector (DIN-8P)

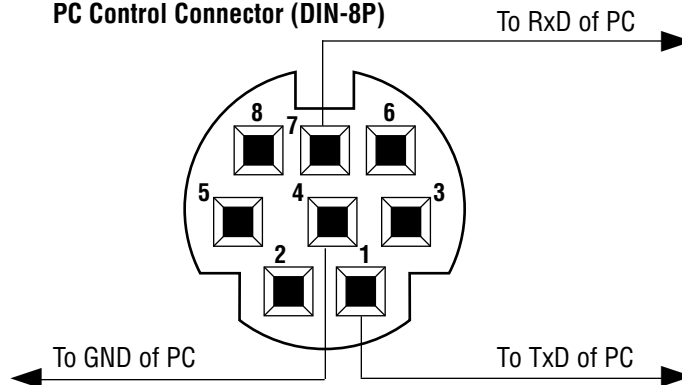

Command Codes (continued)

No.	Function	Code	Data	Description
33	Lamp Reset	27H	No	Lamp usage hour is reset to 0
34	S-VIDEO	C6H	No	Same as remote
35	Brightness	60H	Yes	0 to 63
36	Contrast	62H	Yes	0 to 63
37	Color	64H	Yes	0 to 63
38	Tint	66H	Yes	-32 to +31(E0 to 1F)
39	Sharpness	68H	Yes	0 to 3
40	Audio Volume	6AH	Yes	0 to 63
41	Fine Picture	6EH	Yes	0 to 15
42	Picture Adj	70H	Yes	0 to 255
43	H Position	72H	Yes	-32 to +31(E0 to 1F)
44	V Position	74H	Yes	-32 to +31(E0 to 1F)

WARNING

TO PREVENT FIRE OR SHOCK, DO NOT EXPOSE THIS UNIT TO RAIN OR MOISTURE. DO NOT USE THIS UNIT'S GROUNDED PLUG WITH AN EXTENSION CORD OR IN AN OUTLET UNLESS ALL THREE PRONGS CAN BE FULLY INSERTED. DO NOT OPEN THE CABINET. THERE ARE HIGH-VOLTAGE COMPONENTS INSIDE. ALL SERVICING MUST BE DONE BY QUALIFIED NEC SERVICE PERSONNEL.

RF Interference

WARNING

The Federal Communications Commission does not allow any modifications or changes to the unit EXCEPT those specified by NEC Technologies in this manual. Failure to comply with this government regulation could void your right to operate this equipment.

This equipment has been tested and found to comply with the limits for a Class A digital device, pursuant to Part 15 of the FCC Rules. These limits are designed to provide reasonable protection against harmful interference in a commercial installation. This equipment generates, uses and can radiate radio frequency energy and, if not installed and used in accordance with the instructions, may cause harmful interference to radio communications.

Operation of this equipment in a residential area is likely to cause harmful interference in which case the user will be required to correct the interference at their own expense.

This digital apparatus does not exceed the Class A limits for radio noise emissions from digital apparatus as set out in the Radio Interference Regulations of the Canadian Department of Communications.

Important Safeguards

These safety instructions are to ensure the long life of your LCD projector and to prevent fire and shock. Please read them carefully and heed all warnings.

Installation

1. For the best results, use the LCD projector in a darkened room.
2. Place the LCD projector on a flat, level surface and in a dry area free from dust and moisture.

3. Do not place the LCD projector in direct sunlight, near heaters or heat radiating appliances.
4. Exposure to direct sunlight, smoke or steam could harm internal components.
5. Handle your LCD projector carefully. Dropping or jarring your projector could damage internal components.
6. Do not place heavy objects on top of the LCD projector.
7. If installing the LCD projector on the ceiling:
 - a. The ceiling must be strong enough to support the LCD and the installation must in accordance with any local building codes.
 - b. The LCD projector must be installed by qualified NEC service personnel.

14	D Down	85H	No	Same as remote
15	D Right	5EH	No	Same as remote
16	D Left	5FH	No	Same as remote
17	X2/X4	87H	No	Same as remote
18	Freeze	91H	No	Same as remote
19	Front Floor	15H	No	
20	Front Ceiling	16H	No	
21	Rear Floor	17H	No	
22	Rear Ceiling	18H	No	
23	Auto Start On	19H	No	
24	Auto Start Off	1AH	No	
25	Auto Picture On	1BH	No	
26	Auto Picture Off	1CH	No	
27	Highcontrast On	1DH	No	
28	Highcontrast Off	1EH	No	
29	Power MGT On	23H	No	
30	Power MGT Off	24H	No	
31	800x600 Mode	25H	No	
32	640x480 Mode	26H	No	

PC Control Command Reference

Command Codes

No.	Function	Code	Data	Description
01	Video	03H	No	Same as remote
02	RGB	04H	No	Same as remote
03	Power On	08H	No	Same as remote (See page 62.)
04	Power Off	14H	No	Same as remote
05	Picture Mute	47H	No	Same as remote
06	Audio Mute	45H	No	Same as remote
07	Onscreen Mute	11H	No	Same as remote
08	Power Zoom W	09H	No	Same as remote
09	Power Zoom T	0AH	No	Same as remote
10	Power Focus +	0BH	No	Same as remote
11	Power Focus -	0CH	No	Same as remote
12	Reset	43H	No	Same as remote (Resets immediately after returning ACK)
13	D Up	84H	No	Same as remote

Power Supply

1. The LCD projector is designed to operate on a power supply of 110-120/220-240 V 50/60 Hz AC. Ensure that your power supply fits this requirement before attempting to use your LCD projector.
2. Handle the power cable carefully and avoid excessive bending. A damaged cord can cause electric shock or fire.
3. If the LCD projector is not to be used for an extended period of time, disconnect the plug from the power outlet.

Cleaning

1. Unplug the LCD projector before cleaning.
2. Clean the cabinet periodically with a damp cloth. If heavily soiled, use a mild detergent. Never use strong detergents or solvents such as alcohol or thinner.
3. Use a blower or lens paper to clean the lens, and be careful not to scratch or mar the lens.
4. Clean the air filter with a vacuum cleaner after every 100 hours of operation.
 - a. Do not use water or any other liquid to clean the air filter.
 - b. Do not operate your LCD projector without the air filter.

Fire and Shock Precautions

1. Ensure that there is sufficient ventilation and that vents are unobstructed to prevent the build-up of heat inside your LCD projector. Allow at least 3 inches (10cm) of space between your LCD projector and a wall.
2. Prevent foreign objects such as paper clips and bits of paper from falling into your LCD projector. Do not attempt to retrieve any objects that might fall into your projector. Do not insert any metal objects such as a wire or screwdriver into your LCD project. If something should fall into your projector, disconnect it immediately and have the object removed by a qualified NEC service person.
3. Do not place any liquids on top of your LCD projector.

Do not look into the lens while the projector is on. Serious damage to your eyes could result.

ATTENTION

RISQUE D'ELECTROCUTION NE PAS OUVRIR

ATTENTION

AFIN DE REDUIRE LES RISQUES D'ELECTROCUTION, NE PAS ENLEVER LE COUVERCLE. AUCUN DES ELEMENTS INTERNES NE DOIT ETRE REPARÉ PAR L'UTILISATEUR. LAISSER A UN PERSONNEL QUALIFIÉ LE SOIN DE REPARER CET APPAREIL.



Ce symbole a pour but de prévenir l'utilisateur de la présence d'une tension dangereuse, non isolée se trouvant à l'intérieur de l'appareil. Elle est d'une intensité suffisante pour constituer un risque d'électrocution. Éviter le contact avec les pièces à l'intérieur de cet appareil.



Ce symbole a pour but de prévenir l'utilisateur de la présence d'importantes instructions concernant l'entretien et le fonctionnement de cet appareil. Par conséquent, elles doivent être lues attentivement afin d'éviter des problèmes.

Y	MAC	640 x 480	66.67	35	30.24
Y	VESA	640 x 480	75	37.5	31.5
Y	VESA	640 x 480	72	37.86	31.5
Y	IBM	640 x 480	75	39.38	31.5
N	MAC	640 x 870	75	68.85	57.28
Y	IBM	720 x 350	70	31.47	28.322
Y	IBM	720 x 400	70	31.47	28.322
N	IBM	720 x 350	87	39.44	35.5
N	IBM	720 x 400	87	39.44	35.5
Y	VESA	800 x 600	56.25	35.16	36
Y	VESA	800 x 600	60.32	37.88	40
#	VESA	800 x 600	75	46.88	49.5
#	VESA	800 x 600	72.19	48.08	50

Incompatible signals are listed "N" and hatched. VESA 800x600 image are compressed into 640x480. Marked "#" signal, horizontal image is compressed 20%.

Timing Chart

Y/N		Resolution	Refresh Rate (Hz)	F.H. (kHz)	Dot Clk (MHz)
Y	NTSC	640 x 480	60	15.73	
Y	PAL	640 x 480	50		
N	MAC	512 x 384	60.15	24.48	15.67
N	MAC	512 x 384	60.15	24.48	17.234
N		640 x 395	55	24	20.35
Y	NEC	640 x 400	56	24.83	21.053
Y	IBM	640 x 400	70	31.47	25.175
Y	IBM	640 x 480	60	31.47	25.175
Y	MAC	640 x 480	60	31.47	25.175
Y	NEC	640 x 400	70	31.47	25.175
Y	NEC	640 x 480	60	31.47	25.175
Y	VESA	640 x 480	59.94	31.47	25.175
Y	MAC	640 x 480	66.67	34.97	31.334
Y	MAC	640x400	66	35	30.24

AVERTISSEMENT

AFIN DE REDUIRE LES RISQUES D'INCENDIE OU D'ELECTROCUTION, NE PAS EXPOSER CET APPAREIL A LA PLUIE OU A L'HUMIDITE. AUSSI, NE PAS UTILISER LA FICHE POLARISEE AVEC UN PROLONGATEUR OU UNE AUTRE PRISE DE COURANT SAUF SI CES LAMES PEUVENT ETRE INSEREES A FOND. NE PAS OUVRIR LE COFFRET, DES COMPOSANTES HAUTE TENSION SE TROUVENT A L'INTERIEUR. LAISSER A UN PERSONNEL QUALIFIE LE SOIN DE REPARER CET APPAREIL.

DOC avis de conformation

Cet appareil numérique de la classe A respecte toutes les exigences du Règlement sur le Matériel D'interférence du Canada.

Importantes précautions de sécurité

Les points suivants sont des précautions de sécurité importantes destinées à garantir une longue durée de service du projecteur à écran à cristaux liquides (LCD) et afin d'éviter un incendie et des risques d'électrocution. S'assurer de lire attentivement ces précautions de sécurité et respecter tous les avertissements décrits ci-dessous.

Installation

1. Pour un fonctionnement optimal, utiliser le projecteur à écran à cristaux liquides (LCD) dans une pièce sombre.
2. Placer le projecteur à écran à cristaux liquides (LCD) sur une surface à niveau et dans un endroit sec exempt de poussières et d'humidité.
3. Ne pas placer le projecteur à écran à cristaux liquides (LCD) en plein soleil, près d'appareils ménagers ou d'autres appareils de chauffage.

4. La fumée, la vapeur et l'exposition aux rayons directs du soleil risquent de détériorer sérieusement les composantes internes.
5. Eviter des manipulations brusques lors du déplacement du projecteur à écran à cristaux liquides (LCD), car un choc violent pourrait endommager les composantes internes.
6. Ne pas déposer d'objets lourds sur le dessus du projecteur à écran à cristaux liquides (LCD).
7. Lors de l'installation du projecteur à écran à cristaux liquides (LCD) au plafond, respecter les instructions suivantes.
 - a. Le plafond doit être suffisamment solide pour supporter le poids du projecteur à écran à cristaux liquides (LCD) et il doit être installé selon les codes de construction locaux.
 - b. Le projecteur à écran à cristaux liquides (LCD) doit être installé par un personnel qualifié.

Alimentation

1. Le projecteur à écran à cristaux liquides (LCD) est conçu pour fonctionner à 110-120/220-240VCA 50/60Hz. S'assurer que la tension d'alimentation locale satisfait cette exigence avant d'utiliser le projecteur.
2. Manipuler le câble d'alimentation avec précaution et éviter de le plier excessivement. Un cordon endommagé risque de provoquer une électrocution ou un incendie.
3. Si le projecteur à écran à cristaux liquides (LCD) n'est pas utilisé pendant une période prolongée, retirer la fiche de la prise secteur.

D-Sub Pin Assignments

PC 15-Pin mini D-Sub

Pin No.	Signal to be connected
1	Red
2	Green
3	Blue
4	GND
5	No Connection
6	Red GND
7	Green GND
8	Blue GND
9	No Connection
10	Digital GND
11	GND
12	No Connection
13	Horizontal Sync
14	Vertical Sync
15	No Connection

Macintosh 15-Pin D-Sub

Pin No	Signal to be connected
1	Red GND
2	Red
3	Horizontal Sync
4	GND
5	Green
6	Green GND
7	No Connection
8	No Connection
9	Blue
10	No Connection
11	GND
12	Vertical Sync
13	Blue GND
14	No Connection
15	No Connection

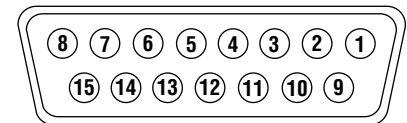
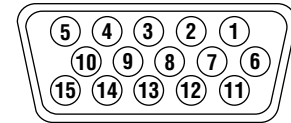

Nettoyage

1. Débrancher le projecteur à écran à cristaux liquides (LCD) de la prise d'alimentation avant le nettoyage.
2. Nettoyer régulièrement le coffret avec un chiffon doux. S'il y a des taches tenaces, utiliser une solution d'un détergent doux. Ne jamais utiliser de détergents puissants ou des solvants, tel que l'alcool ou un diluant pour nettoyer le projecteur à écran à cristaux liquides (LCD).
3. Utiliser un appareil diffuseur chauffant ou du papier de nettoyage de lentille disponible dans le commerce pour nettoyer la lentille.
4. Ne pas frapper ou rayer la surface de la lentille, car des défauts risquent de se produire sur la surface de la lentille.
5. Nettoyer le filtre à air toutes les 100 heures.
 - a. Nettoyer seulement l'extérieur avec un aspirateur.
 - b. Ne pas nettoyer le filtre à air avec de l'eau ou un liquide.
 - c. Ne pas utiliser le projecteur à écran à cristaux liquides (LCD) sans le filtre à air.

Précautions pour éviter un incendie ou une électrocution

1. Une ventilation appropriée doit être assurée afin d'éviter une accumulation de chaleur à l'intérieur du projecteur à écran à cristaux liquides (LCD). S'assurer que les trous de ventilation ne sont pas obstrués. Laisser un espace d'au moins 10 cm (quatre pouces) entre le projecteur à écran à cristaux liquides (LCD) et les murs.
2. Eviter que des objets étrangers, des agrafes, des clous et du papier, par exemple, pénètrent à l'intérieur du projecteur à écran à cristaux liquides (LCD). Ne pas essayer de récupérer ces objets soi-même ou ne pas insérer des objets métalliques, des fils et des tourne-vis, par exemple à l'intérieur du projecteur à écran à cristaux liquides (LCD). Si un objet tombe à l'intérieur du projecteur à écran à cristaux liquides (LCD), le débrancher immédiatement et contacter un réparateur qualifié pour retirer l'objet.
3. Ne pas placer des liquides sur le dessus du projecteur à écran à cristaux liquides (LCD).

Ne pas regarder dans la lentille, car cela risque de provoquer des lésions oculaires.

NEC MultiSync® LCD Projector Products

NEC Technologies, Inc. (hereafter NECTECH) warrants this product to be free from defects in material and workmanship under the following terms.

HOW LONG IS THE WARRANTY?

Parts and labor are warranted for (1) one year from the date of the first customer purchase. The lamp is warranted for 2000 hours of operating time or six months, whichever comes first.

WHO IS PROTECTED?

This warranty may be enforced only by the first purchaser.

WHAT IS COVERED AND WHAT IS NOT COVERED

Except as specified below, this warranty covers all defects in material or workmanship in this product. The following are not covered by the warranty:

1. Any product which is not distributed in the U.S.A., Canada and Mexico by NECTECH or which is not purchased in the U.S.A., Canada and Mexico from an authorized NECTECH dealer. If you are uncertain as to whether a dealer is authorized, please contact NECTECH at 800-836-0655.

2. Any product on which the serial number has been defaced, modified or removed.
3. Damage, deterioration or malfunction resulting from:
 - a. Accident, misuse, abuse, neglect, fire, water, lightning or other acts of nature, unauthorized product modification, or failure to follow instructions supplied with the product.
 - b. Repair or attempted repair by anyone not authorized by NECTECH.
 - c. Any shipment of the product (claims must be presented to the carrier).
 - d. Removal or installation of the product.
 - e. Any other cause which does not relate to a product defect.
4. Cartons, carrying cases, batteries, external cabinets, magnetic tapes, or any accessories used in connection with the product.

WHAT WE WILL PAY FOR AND WHAT WE WILL NOT PAY FOR

We will pay labor and material expenses for covered items. But we will not pay for the following:

1. Removal or installation charges.

Electrical

Inputs	Video (NTSC/PAL/SECAM/M-NTSC) RGB (H: 15-39kHz)
Video Bandwidth	32 MHz
Color Reproduction	Full color, 16.7 million colors simultaneously.
Horizontal Resolution	NTSC 550, PAL 350, SECAM 350, M-NTSC 350 TV lines RGB 640 dots horizontal, 480 dots vertical
Power Requirement	110-120/220-240 VAC, 50/60 Hz
Input Current	4.6 A
Dimensions	12.7" (W) x 5.9" (H) x 16.0" (D) 32.2cm (W) x 15.0cm (H) x 40.73cm (D) (not including lens cap and feet)
Net Weight	15.87 lbs (7.2 kg)
Operational Temperatures	LCD projector: 32°-104°F (0° to 40°C), 20-80% humidity Remote control: 32°-140°F (0° to 60°C) IR receiver: 32°-140°F (0° to 60°C)
Regulations	UL Approved (UL 1950, CSA 950) Meets DOC Canada requirements FCC Class A

This section provides technical information about the MultiSync MT600 LCD Projector's performance.

Optical

LCD Panel	1.3" p-Si with 640 x 480 dots
Lens	Power zoom, power focus F 3.5 f =52-73 mm
Lamp	Metal halide lamp 250 W (Guaranteed life span: 2,000 hours or 6 months from date of purchase, whichever comes first.)
Image Size	20-300 inches diagonal
Projection Distance	3.28-39.37 ft (1.0-12 m)
Image Brightness	Light output: 400 ANSI lumens
Contrast Ratio	200 : 1
Color Temperature	7,500 Kelvin

- Costs of initial technical adjustments (set-up), including adjustment of user controls. These costs are the responsibility of the NECTECH dealer from whom the product was purchased.
- Payment of shipping charges.

HOW YOU CAN GET WARRANTY SERVICE

- To obtain service on your product, consult the dealer from whom you purchased the product.
- Whenever warranty service is required, the original dated invoice (or a copy) must be presented as proof of warranty coverage. Please be prepared to describe or demonstrate the problem to your dealer.
- For the name of the nearest NECTECH authorized service center, call NECTECH at 800-836-0655.

LIMITATION OF IMPLIED WARRANTIES

ALL IMPLIED WARRANTIES, INCLUDING WARRANTIES OF MERCHANTABILITY AND FITNESS FOR A PARTICULAR PURPOSE, ARE LIMITED IN DURATION TO THE LENGTH OF THIS WARRANTY.

EXCLUSION OF DAMAGES

NECTECH'S LIABILITY FOR ANY DEFECTIVE PRODUCT IS LIMITED TO THE REPAIR OR REPLACEMENT OF THE PRODUCT AT OUR OPTION. NECTECH SHALL NOT BE LIABLE FOR:

- DAMAGE TO OTHER PROPERTY CAUSED BY ANY DEFECTS IN THIS PRODUCT, DAMAGES BASED UPON INCONVENIENCE, LOSS OF USE OF THE PRODUCT, LOSS OF TIME, COMMERCIAL LOSS; OR
- ANY OTHER DAMAGES, WHETHER INCIDENTAL, CONSEQUENTIAL OR OTHERWISE. SOME STATES DO NOT ALLOW LIMITATIONS ON HOW LONG AN IMPLIED WARRANTY LASTS AND/OR DO NOT ALLOW THE EXCLUSION OR LIMITATION OF INCIDENTAL OR CONSEQUENTIAL DAMAGES, SO THE ABOVE LIMITATIONS AND EXCLUSIONS MAY NOT APPLY TO YOU.

HOW STATE LAW RELATES TO THE WARRANTY

This warranty gives you specific legal rights, and you may also have other rights which vary from state to state.

FOR MORE INFORMATION, TELEPHONE 800-366-5213

NECTECHNOLOGIES, INC.
1250 N. Arlington Heights Road, Suite 500
Itasca, Illinois 60143-1248

NOTE: All products returned to NECTECH for service **MUST** have prior approval. To get approval, call NEC Technologies at 800-836-0655.

1. Introduction

Introduction To The MultiSync MT600 LCD Projector	13
How Do You Get Started?	13
What's In The Box?	15
Getting To Know Your MultiSync MT600 LCD Projector	16
Front Features	16
Rear Features	16
Top Features	17
Terminal Panel Features	18
Remote Control Features	20

2. Installation

Setting Up Your MultiSync MT600 LCD Projector	23
Selecting A Location	23
Using A Tabletop Or Cart	24
Ceiling Installation	25
Reflecting The Image	26
Rear Screen Projection	26
Wiring Diagram	27-28
Connecting Your PC Or Macintosh Computer	29
Connecting Your Document Camera	30
Connecting Your VCR Or Laser Disc Player	31
Connecting An External Monitor	31
Connecting Your IR Receiver	32

Problem	Check These Items
Image is scrolling vertically, horizontally or both	Use icons to select the source you want to input.
Remote control does not work	Install new batteries. (See page 44.) Make sure there are no obstacles between you and the projector. Make sure you are within 23 feet (7m) of the projector.
Status indicator is lit or blinking	See the Status Light message chart on page 49.
Cross color in RGB mode	If “Auto Picture” is off, turn it on. If “Auto Picture” is on, turn it off and balance the image with the Picture Adjustment icon and Fine Picture Adjustment icon.

To Contact Your NEC Service Representative, Call 1-800-836-0655

Common Problems & Solutions

Problem	Check These Items
Does not turn on	Check that the cord is plugged in and that the power switch on the back panel is on.
	Ensure that the air filter and filter panel are installed correctly. (See page 43.) Check the status light to see if the projector has overheated.
No picture	Use the menu icons to select your source (Video, S-Video or RGB). (See page 36.) Ensure your cables are connected properly. Use icons to adjust the brightness and contrast. Remove the lens cap.
Image isn't square to the screen	Reposition the projector to improve its angle to the screen.
Picture is blurred	Adjust the focus. (See page 17.) Reposition the projector to improve its angle to the screen. Ensure that the distance between the projector and screen is within the adjustment range of the lens.

3. Operation

General Controls	33
Using The Icons	35
Icon Descriptions And Functions	36
Source Icons	36
Sound and Picture Control Icons	36
Projector Control Icons	37
Maintenance Icons	39

4. Maintenance

Replacing The Lamp	41
Cleaning Or Replacing The Filter	43
Remote Control Battery Installation	44

5. Troubleshooting

Status Light Messages	49
Common Problems & Solutions	51

6. Specifications

Optical	53
Electrical	54
D-Sub Pin Assignments	55
Timing Chart	56
PC Control Command Reference	58
Cable Connection	57

This section introduces you to your new MultiSync MT600 LCD Projector, provides a list of materials that comes with your projector and describes the features and controls.

Congratulations On Your Purchase Of The MultiSync MT600 LCD Projector

The MultiSync MT600 is one of the very best LCD projectors available today. The multiple LCD panels enable you to project precise images up to 300 inches across (measured diagonally) from your PC or Macintosh computer (desktop or notebook), VCR, document camera, or even a laser disc player.

You can use the projector on a tabletop or cart, you can permanently mount it on a ceiling*, or you can use MultiSync MT600 LCD Projector to project images from behind the screen. The remote control can be used wirelessly or with a cable, and you can even use the remote control with the IR receiver to operate the

mouse on your PC or Mac. But best of all, the MultiSync MT600 is an NEC LCD projector. That means you can depend on years of reliable performance and crystal-clear presentations!

The features you'll enjoy include:

- Simple set up and operation.
- A high-performance 250 watt metal halide lamp that delivers 400 lumens (ANSI) and is guaranteed for 2000 hours of service or six months, whichever comes first.
- The "High Contrast" mode creates a clear image from a document camera.
- The power zoom control enables you to adjust the image to be between 20 and 300 inches (measured diagonally).
- The "2X-4X" button allows you to double and quadruple the size of the image with a single click of the remote.
- An image can be projected from in front or behind a screen, and the projector can even be installed on the ceiling.

Condition	Status
Blinking Rapidly (4 times a second)	The projector is overheated. The lamp turns off automatically. Allow the fan to run at least two minutes before unplugging the projector. Then check the filter and clean it if necessary. If there is insufficient ventilation around the projector or if the room where you're presenting is particularly warm, move the projector to a cooler location. In either case, allow at least five minutes before turning the projector back on. If the problem persists, contact your NEC dealer for service.

This section helps you resolve problems you may encounter while setting up or using your MultiSync MT600 LCD Projector.

Status Light Messages

Condition	Status
OFF	Normal
On Continually	The projector lamp has exceeded 2000 hours of operation and should be replaced.
Blinking Slowly (Once a second)	<p>Check the filter and clean it if necessary. Ensure that the filter panel is installed properly.</p> <p>Wait one minute before using the remote control. Otherwise the lamp may not go on.</p>

- Supports most IBM VGA, S-VGA (pseudo), Macintosh or any other RGB signals within a horizontal frequency range of 15 to 40 kHz and a vertical frequency range of 50 to 75 Hz. This includes NTSC, PAL, SECAM, and M-NTSC standard video signals.

Note: Composite video standards are as follows:

NTSC: U.S. TV standard for video in U.S. and Canada.

PAL: TV standard used in western Europe

SECAM: TV standard used in France and Eastern Europe

M-NTSC: (modified-NTSC)-result of converting a video in the SECAM standard to the NTSC standard

- The remote control can be used with or without a cable, and you can even use the remote to operate your PC or Macintosh mouse wirelessly from across the room with the IR receiver module.
- You can control your MultiSync MT600 LCD Projector with a PC.
- The contemporary cabinet design is compact, easy to carry, and complements any office, board room or auditorium.
- * Installing the MultiSync MT600 LCD Projector on the ceiling must be done by authorized NEC technicians. Consult your NEC dealer for more information.

How Do You Get Started?

The fastest way to get started is to take your time and do everything right the first time. Taking a few minutes now to watch the introductory video and review the manual may save you hours later on. At the beginning of each section of the manual you'll find an overview. If the section doesn't apply, you can skip it.

What's In The Box?

Make sure your box contains everything listed. If any pieces are missing, contact your dealer. Please save the original box and packing materials if you ever need to ship your MultiSync MT600 LCD Projector.

- NEC MultiSync MT600 LCD Projector
- Remote Control And Cable
- IR Receiver And Cable
- PC/Macintosh MultiCable (15-Pin Mini D-Sub To 15-Pin D-Sub Connector)
- Power Cable
- Four AAA Batteries
- Introductory Video
- User's Manual
- Accessory Catalog
- Warranty Registration Card

AVERTISSEMENT

- Nettoyer seulement l'extérieur du filtre avec un aspirateur.
- Ne pas nettoyer à l'intérieur du projecteur où le filtre est situé, il y a une étiquette d'avertissement.
- Ne pas essayer de faire fonctionner le projecteur sans un filtre.
- Votre projecteur à écran à cristaux liquides (LCD) ne fonctionnera pas si le filtre est installé incorrectement.
- Ne pas arrêter le projecteur à écran à cristaux liquides (LCD) sauf pour remplacer l'ampoule et/ou le filtre à air.

Installation des batteries de l'appareil à télécommande.

1. Presser fermement sur le point "A" et enlever le couvercle des batteries en le glissant.
2. Enlever les quatres vieilles batteries et installer de nouvelles batteries (AAA). Assurez vous d'aligner correctement la polarité (+/-)
3. Glisser le couvercle de protection des batteries en place jusqu'à ce que vous entendiez un claquement.

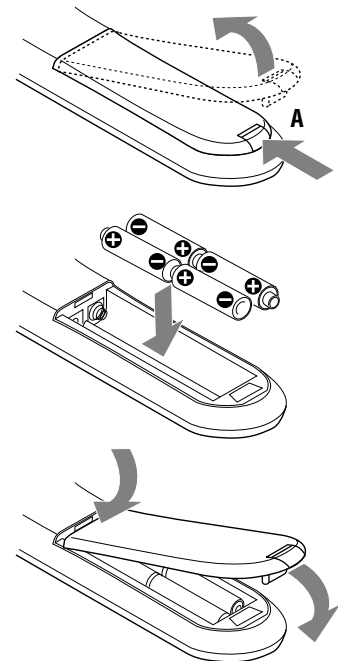

Nettoyer et remplacer le filtre

Le filtre à air éponge empêche la poussière et la saleté de pénétrer à l'intérieur du projecteur à écran à cristaux liquides (LCD) et devrait être nettoyé après 100 heures d'usage (plus souvent dans les endroits très poussiéreux). Si le filtre est sale ou bouché, votre projecteur peut surchauffer.

NOTE: Nettoyer votre filtre après 100 heures d'usage.

Pour nettoyer le filtre à air:

1. Fermer le contact de courant du projecteur à écran à cristaux liquides (LCD) et attendre que le ventilateur arrête. Fermer le contact de courant principal et débrancher le câble électrique.
2. Enlever le panneau du filtre en poussant sur le bas du couvercle jusqu'à ce que vous sentiez un détachement du couvercle.
3. Remplacer avec un nouveau filtre ou nettoyer le filtre en place à fond avec un aspirateur. Ne pas laver le filtre avec de l'eau et du savon, l'eau et le savon vont endommager la membrane du filtre.
4. Remettre le filtre en place ou installer le nouveau filtre. Remettre le panneau du filtre en place.

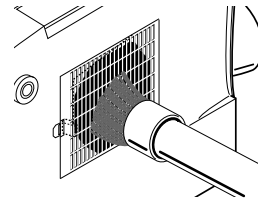
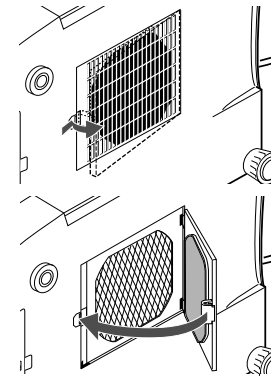

Getting To Know Your MultiSync MT600 LCD Projector

Front Features

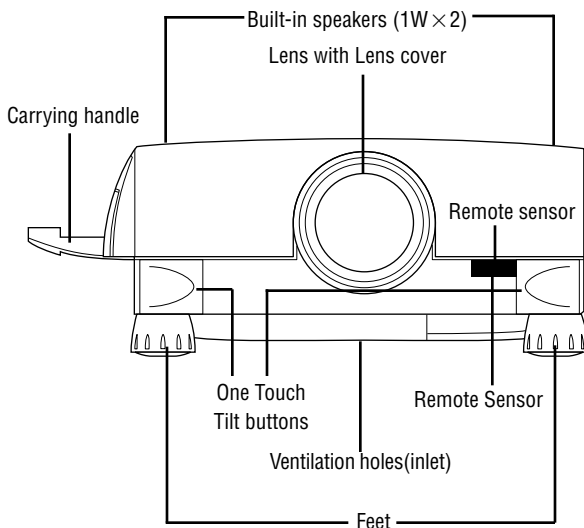

Rear Features

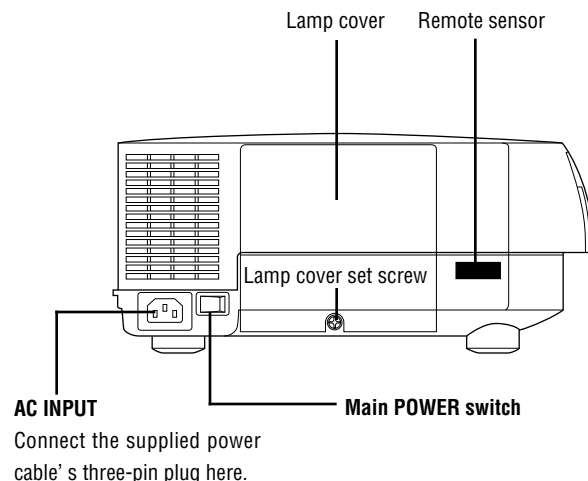

Top Features

1. **Power Button** Use this button to turn the power on and off when Main Power Switch is on and the LCD projector is on standby. (When this button is pressed and held for at least two seconds, the “Display Mute” mode will be canceled.)
2. **Menu Button** Displays the icons you need to select a source or adjust your image.
3. **Select Button** After you press the “Menu” button, use this button to select the menu icon of the item you wish to adjust. (If the icons don’t appear after you press the “Menu” button, hold down the “Select” button while using the (+) (-) focus button to adjust the image up or down until the icons do appear.)
4. (+) (-) Zoom/Focus Buttons
 - a. Use these buttons to increase or decrease the level of a selected menu item. An on-screen gauge will appear to show you how the level is changing. These buttons also turn a selected menu item on (+) or off (-).
 - b. Zoom: Hold down the “Zoom” button while you press the (+) button to make the image larger; or press (-) to make the image smaller.
 - c. Focus: Hold down the “Select” button while you press the (+) or (-) buttons to focus an image.
5. **Power Indicator** When this indicator is green, the LCD projector is on; when the indicator is amber, it is standing by.
6. **Status Indicator** When this is lit red continually, it’s warning you that the projection lamp has exceed 2000 hours of service. After this light appears, it is advisable to replace the projection lamp as soon as possible. (See page 41.)

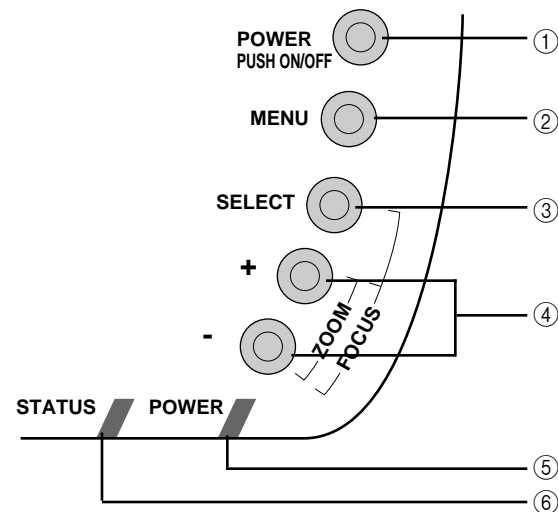

5. Installer une nouvelle ampoule et fixer le coffret de l’ampoule avec les deux vis.

PRECAUTION: Ne pas utiliser d’autres ampoules que l’ampoule NEC en option.
Faire la commande avec le numéro de modèle de votre projecteur.

6. Replacer le couvercle de l’ampoule et fixer avec la vis.

7. Après l’installation de la nouvelle ampoule, sélectionner l’icône de l’usage de l’ampoule, presser sans relâcher le bouton “Power On” sur l’appareil à télécommande pendant 10 seconds afin de remettre l’horloge de l’ampoule à zéro.

NOTE: Quand vous remplacez l’ampoule, il est recommandé de changer aussi le filtre.

ATTENTION: Le filtre est inclus dans l’emballage de la nouve

PRECAUTION: Ne pas arrêter le projecteur à écran à cristaux liquides (LCD) sauf pour remplacer l’ampoule et/ou le filtre à air.

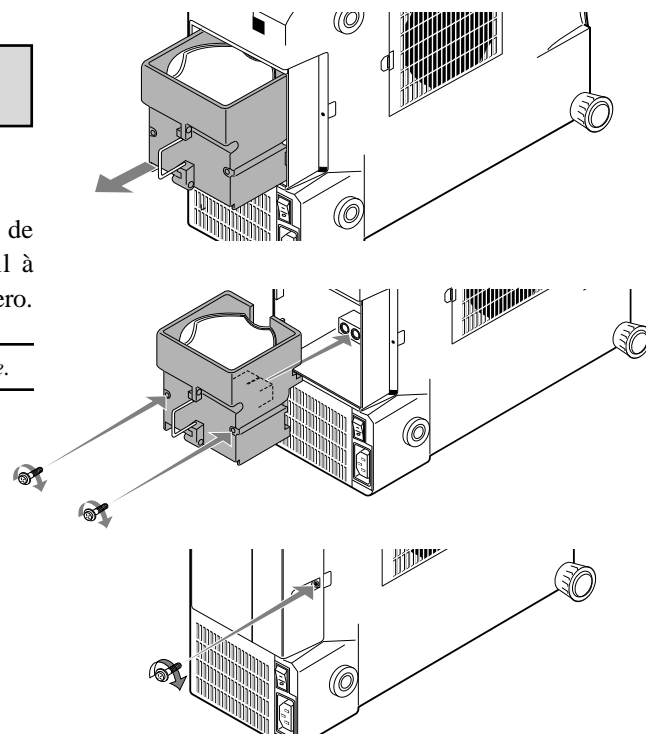

REEMPLACER L'AMPOULE

Après un fonctionnement de 2000 heures ou plus, un signal lumineux s'affichera dans le coffret de l'appareil. Même si l'ampoule demeure fonctionnelle,

ATTENTION

- NE PAS TOUCHER A L'AMPOULE immédiatement après usage. Celle-ci sera extrêmement chaude. Attendre au moins une heure pour laisser l'ampoule refroidir av
- NE PAS ENLEVER D'AUTRES VIS que la vis fixant le couvercle de l'ampoule et les deux vis du coffret de l'ampoule car cela peut provoquer une électrocution.

Pour remplacer l'ampoule:

1. Fermer le contact principal de courant du projecteur à écran à cristaux liquides (LCD) et débrancher le câble électrique.
2. Enlever la vis qui fixe le couvercle de l'ampoule en place et enlever le couvercle.
3. Enlever les deux vis qui maintiennent le coffret de l'ampoule. (Il y a un enclenchement sur ce coffret pour prévenir les risques d'électrocution.)
4. Utiliser la poignée du coffret de l'ampoule pour le désassemblage.

If this light blinks red rapidly, it indicates that either the lamp cover or filter cover is not attached properly. It may also indicate that the projector's internal temperature is too high to operate safely. In either case, the projector will not work until the situation is corrected.

Terminal Panel Features

This panel is located below the projector's handle and is where you connect your cables. To gain access, push on the upper right hand corner of the panel door.

1. **Remote Control Jack** Connect your remote control cable here.
2. **PC Control Connector** Use this jack to connect your PC to control the MultiSync MT600 Projector. This allows you to utilize your PC and serial communication protocol to control the projector. If you are writing your own program, refer to page 59 for command references.
3. **S-Video Input** Here is where you connect S-Video input from an external source like a VCR.

NOTE: S-Video format provides more vivid color and higher resolution than the traditional composite video format.

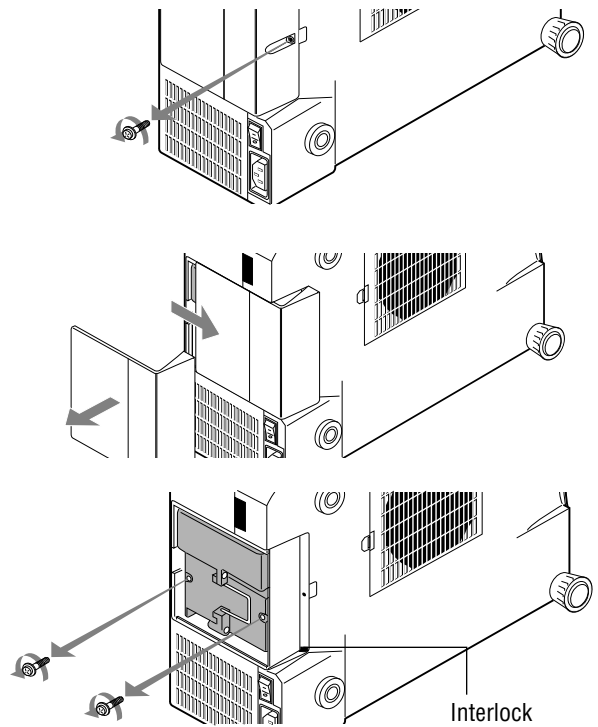

45

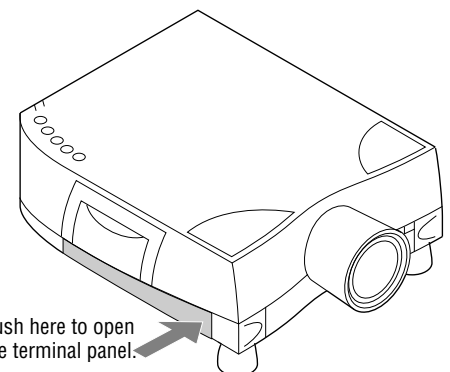

4. **Left Channel/Mono Audio Input Jack** This is your left channel audio input for stereo sound coming from video equipment or audio system. It also serves as the mono audio input for S-Video input.
5. **Right Channel Audio Input Jack** This is your right channel audio input for stereo sound.
6. **Video Input** Connect a VCR or laser disk player here to project the video.
7. **RGB-Input/Through-Put Connectors** Attach either end of the MultiCable to computer or document camera, and then attach the other end to either of these two connectors. You can then use the remaining connector, if you wish, to output the video signal to a monitor. (If you do use a second monitor, turn the monitor switch

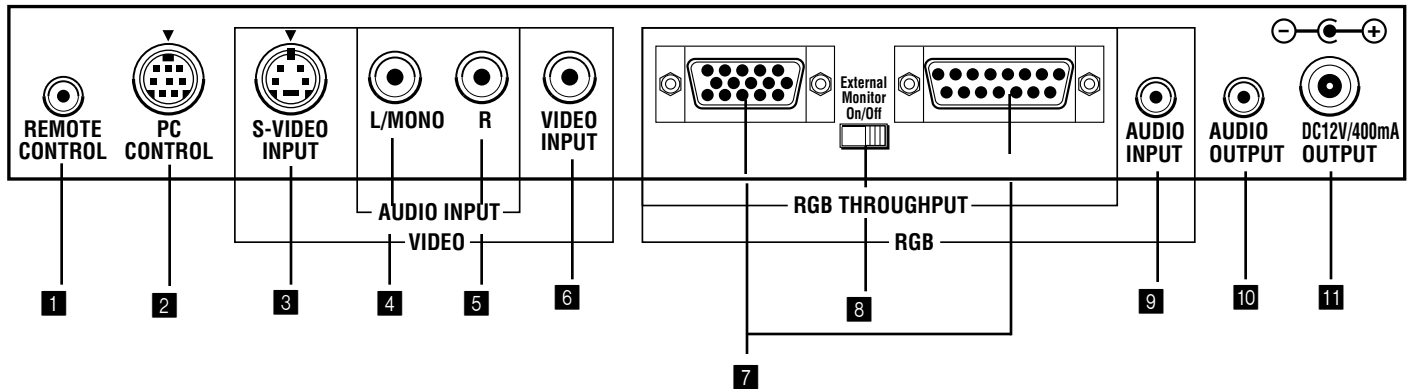

CAUTION

- Only clean the outside of the filter with a vacuum cleaner.
- Do not clean inside the projector where the filter is positioned and the caution label is placed.
- Do not attempt to operate the projector without a filter.
- Your LCD projector will not operate unless the filter is installed correctly.
- Do not put the LCD projector on end except for lamp and/or air filter replacement.

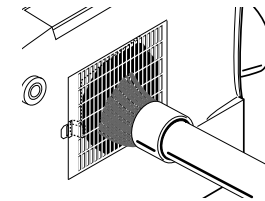

Remote Control Battery Installation

1. Press firmly on point “A” and slide the battery cover off.
2. Remove all four old batteries and install new ones (AAA). Ensure that you have the batteries’ polarity (+/-) aligned correctly.
3. Slip the cover back over the batteries until it snaps into place.

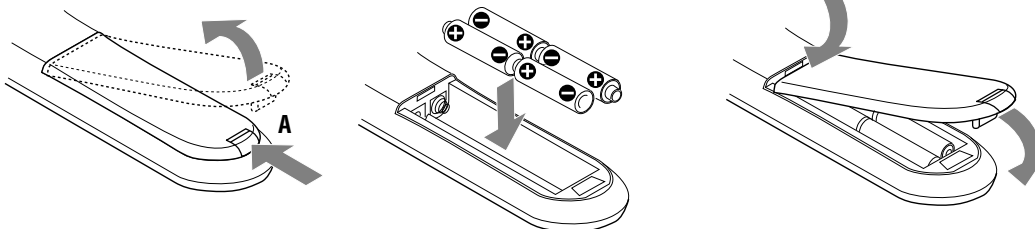

Cleaning Or Replacing The Filter

The air-filter sponge keeps the inside of the MultiSync MT600 LCD Projector free from dust or dirt and should be cleaned after every 100 hours of operation (more often in dusty conditions). If the filter is dirty or clogged, your projector may overheat.

NOTE: Clean your filter after every 100 hours of operation.

To clean or replace the air-filter:

1. Turn off the LCD projector and wait for the fan to stop. Turn off the main power and disconnect the power cable.
2. Remove the filter panel by pushing down on the cover until you feel it detach.
3. Replace it with a new filter or vacuum the filter thoroughly. Do not wash the filter with soap and water. Soap and water will damage the filter membrane.
4. Reposition the filter or put the new filter into place. Reinstall the filter panel.

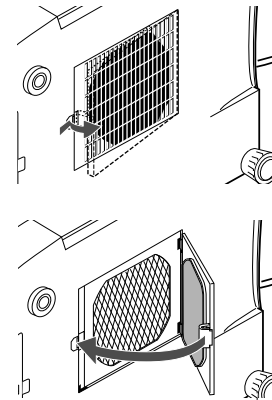

to “on.”) Either connector can be used for input or output, however they cannot both be used for input simultaneously. It can damage your computer.

8. **External Monitor Select Switch** This switch should be “of f” for normal use without external termination or when your RGB signal should be terminated with 75Ω. Switch to the “On” position when you have a monitor attached to your RGB through-put connector.
9. **RGB Audio Input Mini Jack** This is where you connect RGB audio output from a computer or another RGB source.
10. **Audio Output Mini Jack** Connect additional external speakers here to listen to RGB sound coming from your computer.
11. **12V DC Output Terminal** Use this terminal to power a notebook computer or other 12V accessory.

NOTE: When using two video sources simultaneously, the Left Audio Input Terminal should be used for the S-Video source and the Right Audio Input Terminal should be used for the composite video source.

Remote Control Features

You can use your remote control with the cable or wirelessly to operate your MultiSync MT600 LCD Projector. With the IR receiver connected to your computer, you can also use the projector’s remote control to operate your computer’s mouse wirelessly, too. (See page 27 to connect the IR receiver to your computer.)

If you want to use your remote control with the cable, connect one end of the cable to the jack on the remote control and the other end to the Terminal Panel.

1. **Mouse Button** Works as a mouse for your projected computer image. This button is also used to adjust position, zoom and focus.
2. **Position Button** When you're in the 2X or 4X mode, hold this button down and adjust the picture position up and down or left and right with the mouse pad.
3. **Zoom Button** Hold this button down and adjust the picture size (zoom in or out) with the mouse pad.
4. **Focus Button** Hold this button down and adjust the focus with the mouse pad.
5. **2X/4X Button** Pressing this button will enable you to toggle between a standard image, a double-sized (2X) image and a quadrupled image (4X).
6. **RGB Button** Press to select an RGB video source from a computer or document camera.
7. **S-Video Button** Press to select an S-Video source from a VCR.
8. **Video Button** Press to select an NTSC, PAL, SECAM or M-NTSC compatible video source from a VCR or laser disc player.
9. **Freeze Button** This button will freeze a picture.
10. **Menu Button** Use this button to call up the menu of icons to adjust and set the image.
11. **Select Button** Make your on-screen menu selections for adjusting and setting the image with this button. (See page 35.)

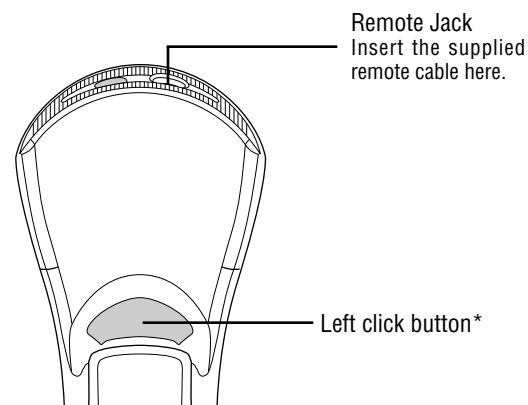

3. Remove the two screws securing the lamp case. (There is an interlock on this case to prevent the risk of electrical shock. Do not attempt to circumvent this interlock.)
4. Use the lamp case handle to remove the assembly.
5. Install a new lamp case assembly and secure it in place with the two screws.

CAUTION: Do not use lamps other than the NEC optional lamp. Order by your projection's model number.

6. Reattach the lamp cover and reinstall the single screw.
7. After you install a new lamp, select the Lamp Usage icon and press and hold the "Power On" button on the remote control for ten seconds to reset the lamp time clock to zero.

NOTE: When you replace the lamp, it is also wise to replace the filter. The filter comes in the same package with your replacement lamp. Contact your NEC dealer for replacement lamps. Order by your projector's model number.

CAUTION: Do not put the LCD projector on end except for lamp and/ or air filter replacement.

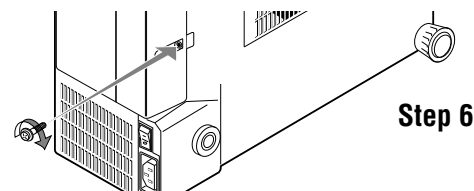
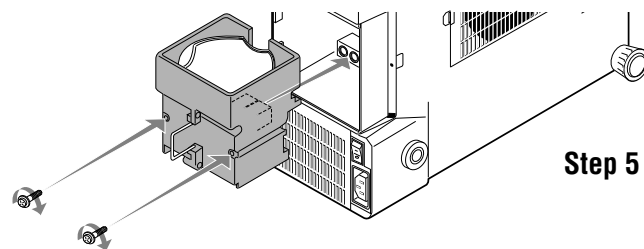
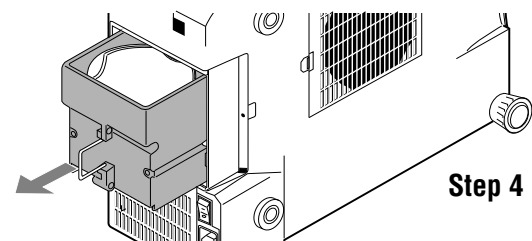

This section describes the simple maintenance procedures you should follow to replace the lamp, clean or replace the filter, and replace the batteries in the remote control.

Replacing The Lamp

After your lamp has been operating for 2000 hours or longer, the “status” light in the cabinet will go on. Even though the lamp may still be working, it is advisable to replace it at 2000 hours to maintain optimal projector performance.

CAUTION

- DO NOT TOUCH THE LAMP immediately after it has been used. It will be extremely hot. Allow at least one hour for the lamp to cool before handling.
- DO NOT REMOVE SCREWS other than the lamp cover set screw and the two lamp case screws as doing so can result in electric shock.

To replace the lamp:

1. Turn off the main power to the MultiSync MT600 LCD Projector and disconnect the power cable.
2. Remove the single screw that secures the lamp housing cover and remove the cover.

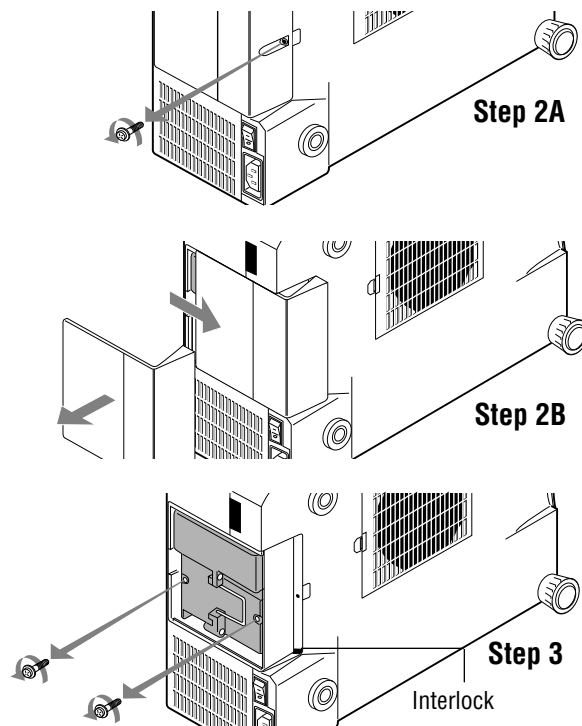

12. (+) (-) **Buttons** After you make your on-screen menu selection use this button to adjust the level up or down. (See page 35.)

13. **Picture Mute Button** This button turns off the image for a short period of time.

14. **Display Mute Button** This button will turn off the on-screen icon menu bar.

15. **Power OnAnd Off** If your main power switch is turned on, you can use this button to turn your MultiSync MT600 LCD Projector on and off.

**NOTE: If you are using a Macintosh computer, you can click either the right or left button to activate the mouse.*

Remote Control Precautions

- When using the remote wirelessly, you should be within 23 feet (7 meters) of the LCD projector and at an angle of no more than 30°.
- When the cable is connected to the remote control, it will not work wirelessly.
- Handle the remote control carefully.
- If the remote control gets wet, wipe it dry immediately.
- Avoid excessive heat and humidity.
- If you will not be using the remote control for a long time, remove the batteries.
- Do not mix new and old or different types of batteries.

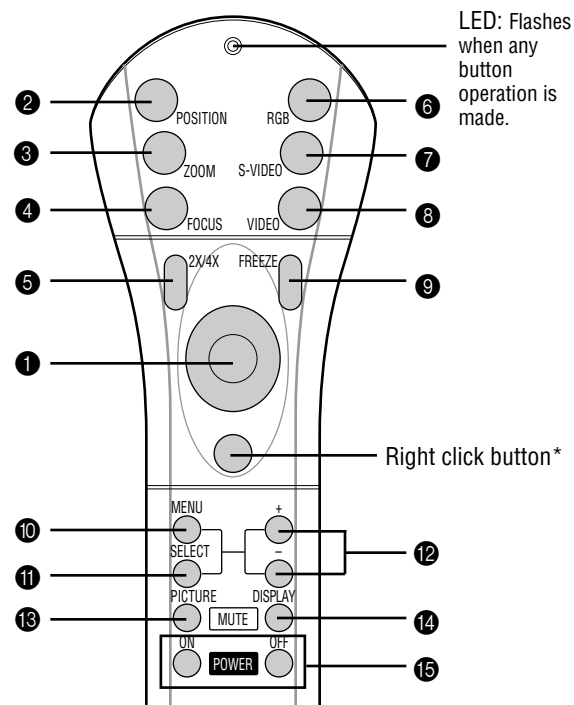

This section describes how to set up your MultiSync MT600 LCD projector and how to connect video and audio sources.

Setting Up Your MultiSync MT600 LCD Projector

Your MultiSync MT600 LCD Projector is simple to set up and use. But before you get started, you must first:

1. Determine the image size
2. Set up a screen or select a non-glossy white wall onto which you can project your image.

Carrying The LCD Projector Always carry your LCD projector by the handle. Ensure that the power cord and any other cables connecting to video sources are disconnected before moving the projector. When moving the projector or when it is not in use, cover the lens with the lens cap.

Selecting A Location The further your LCD projector is from the screen or wall, the larger the image. The minimum size the image can be is approximately 20" (0.5m) measured diagonally when the projector is roughly 3.28 feet (1.0m) from the wall or screen. The largest the image can be is 300" (7.6m) when the projector is about 39 feet (12m) from the wall or screen.

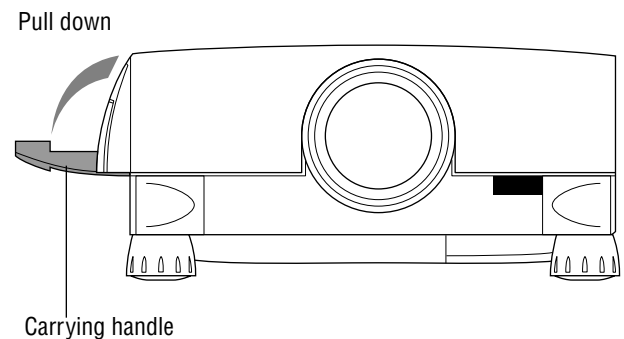

Lamp Usage This tells you how long the lamp has been in operation. It is recommended that you replace a lamp after 2000 hours of service. To see the time used, select this icon and press the (+) button. After you install a new lamp, select this icon and press and hold the "Power On" button for ten seconds to reset the lamp clock back to zero.



Reset Changes all adjustments to the factory preset levels for each source individually. To activate, you must press the (+) button on the cabinet or remote for at least two seconds. The adjustments that will be reset are horizontal and vertical control (for the current image only), picture and fine picture adjustment, brightness, contrast, color, tint, and sharpness.

****NOTE:** The picture, fine picture and auto picture adjustment, and horizontal and vertical position controls will not work with a video source.



Set Position This reorients your image for your type of projection. Press the (+) button until you have the correct image orientation. It moves sequentially: front floor projection - rear ceiling projection - rear floor projection - front ceiling projection. Press the (-) to move backward through the sequence.

Maintenance Icons



Picture Adjustment Use this icon with the “Fine Picture Adjustment” to fine tune the computer image or to remove any vertical banding that might appear. This function adjusts the clock frequencies that eliminate banding in the image. Press the (+) and (-) buttons until the banding disappears. This adjustment may be necessary when you hook your computer up for the first time. This adjustment is made automatically when the Auto Picture is turned on.**



Fine Picture Adjustment Use this icon to adjust the clock phase or to reduce video noise, dot interference or cross talk. (This is evident when parts of the image appear to be shimmering.) Use the (+) and (-) buttons to adjust the image. Use the Fine Picture Adjustment only after the Picture Adjustment is complete. This adjustment is made automatically when the Auto Picture is turned on.**

Using A Tabletop Or Cart

1. Place your LCD projector on a flat level surface at the optimal distance from the screen or wall so you realize the size image you want. (Avoid having bright room lighting or sun light directly on the screen or wall where you'll be projecting the image.)
2. Connect the power cable, remove the lens cap and turn the projector on. (If no input signal is available, the projector will display a black screen.)
3. Ensure that the projector is square to the screen.
4. Move the projector left or right to center the image horizontally on the screen.
5. To center the image vertically, lift the front edge of the projector and press the buttons on the sides of the projector, just above the feet, to release the one-touch tilt feet.
6. To fine tune the image's position vertically on the screen, rotate each front foot. (There is approximately 7° of up and down adjustment for the front of the projector.)
7. Increase or reduce the size of the projected image by pressing the “Zoom” and (+) or (-) buttons on the remote control.

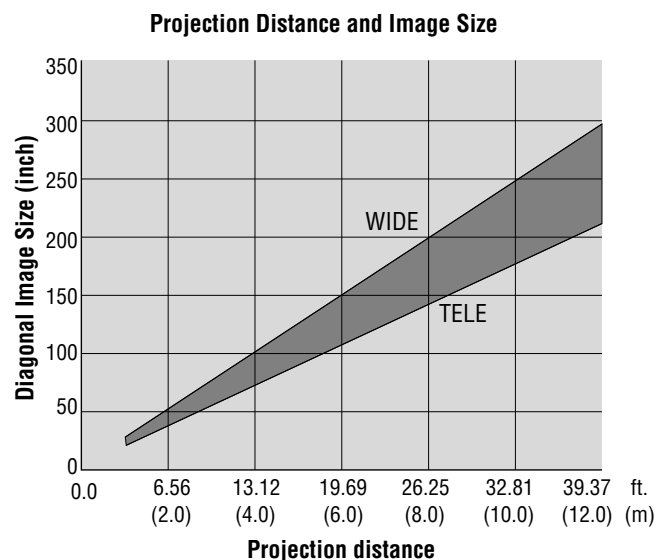

WARNING

- Only use your LCD projector on a solid, level surface. If the projector falls to the ground, you can be injured and the projector severely damaged.
- Do not use the LCD projector where temperatures vary greatly. The projector must be used at temperatures between 32°F (0°C) and 104°F (40°C).
- Do not expose the LCD projector to moisture, dust, or smoke. This will harm the screen image.
- Ensure that you have adequate ventilation around your LCD projector so heat can dissipate. Do not cover the vents on the bottom or back of the projector.

Ceiling Installation

Installing your MultiSync MT600 LCD Projector on the ceiling must be done by a qualified technician. Contact your NEC dealer for more information.

Do not attempt to install the projector yourself.

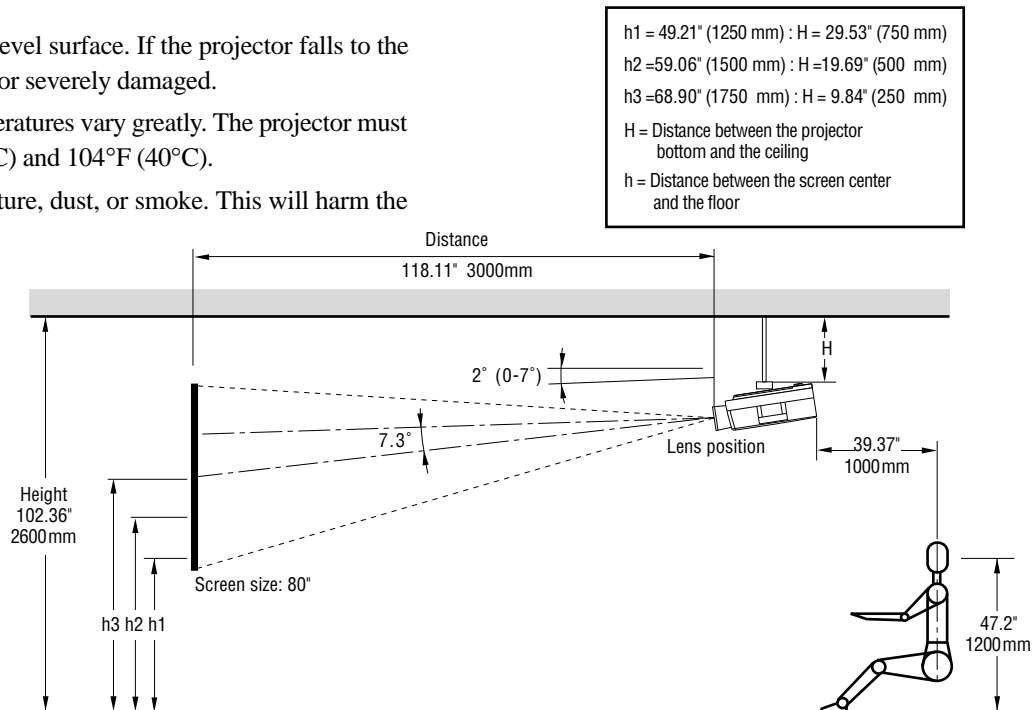

25

Projector Control Icons



Auto Start Turns the LCD projector on automatically when the main power switch is turned on. This eliminates the need to always use the "Power" button on the remote control or projector cabinet.

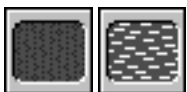

Auto Picture When on, the "Picture" and "Fine Picture" adjustments are made automatically.**



High-Contrast Increases contrast so the image from a document camera is easier to see.

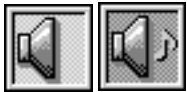

Speakers Turns the projector's speakers on and off.



Power Management When "Power Management" is on and there is no RGB video input for five minutes or more, the projector will automatically turn itself off. Note that VIDEO and S-VIDEO sources are ignored.



Display Mode This toggles your projector between resolutions of 800 x 600 (+) and 640 x 480 (-). The 800 x 600 resolution is only available for signals with a horizontal frequency of 35 kHz or higher. Press (+) if you want to compress an 800 x 600 image into the 640 x 480 display area.



Contrast



Color*



Tint*



Sharpness*



Horizontal Position** [(+) moves the image right, (-) moves it to the left]



Vertical Position** [(+) moves the image up, (-) moves it down]

**NOTE: The color, tint, and sharpness controls will not work with an RGB source. The tint control will not work with a PAL and SECAM source.*

If your projector is mounted on the ceiling and your image is upside down, use the “Menu” and “Select” buttons on your remote control or projector cabinet to access the icons that will correct the orientation. (See page 39.)

Reflecting The Image

Using a mirror to reflect your LCD projector’s image enables you to enjoy a much larger image. Contact your NEC dealer if you need a mirror.

If you’re using a mirror and your image is inverted, use the “Menu” and “Select” buttons on your remote control or projector cabinet to access the icons that will correct the orientation. (See page 39.)

Rear Screen Projection

You can use your MultiSync MT to project an image from the rear onto a transparent screen. The distance the projector must be from the screen is the same as if you were projecting the image from the front. Contact your NEC dealer if you need a transparent screen.

If you’re projecting the image from the rear and your image is inverted, use the “Menu” and “Select” buttons on your remote control or projector cabinet to access the installation icons that will correct the image. (See page 39.)

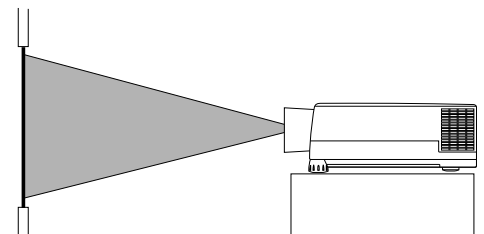
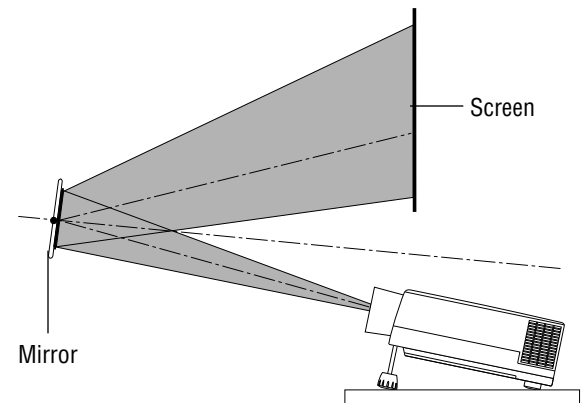

Wiring Diagram

NOTE: The two D-Sub 15-pin connectors here can be used to either input or output video to or from a PC or Macintosh computer. Either connector can be used for input or output, however they cannot both be used for input simultaneously. It can damage your computer.

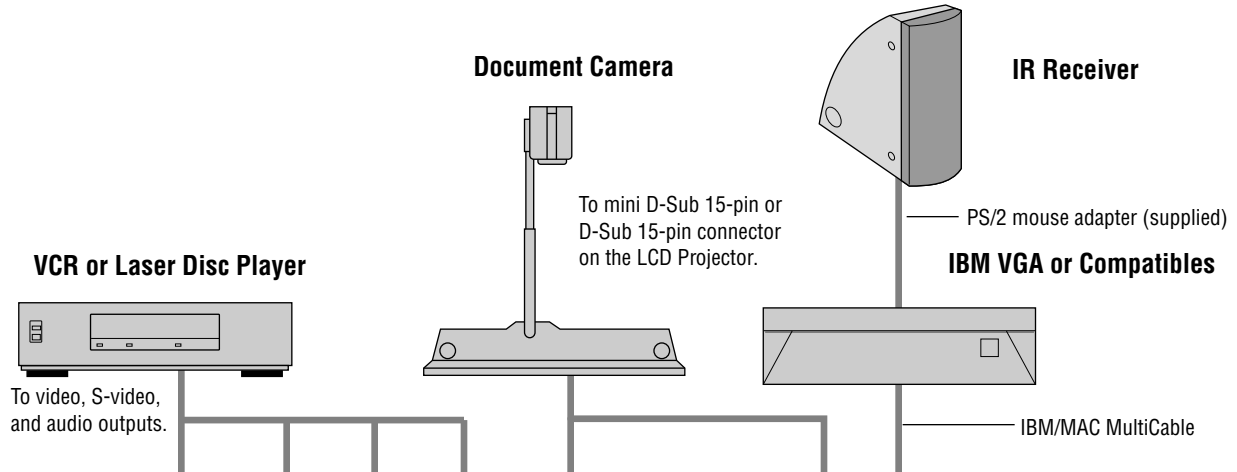

27

Icon Descriptions & Functions

Source Icons



Selects a video source (NTSC, PAL, SECAM, or M-NTSC) such as a VCR or laser disc player.



Selects an S-video source.



Selects an RGB source such as a computer or document camera.

Sound And Picture Control Icons



Volume



Brightness

CAUTION

Do not unplug the projector while the cooling fan is on. The fan will remain on as long as there is heat inside the LCD projector and the main power switch is on.

Using The Icons

1. Press the “Menu” button on the remote control or projector cabinet to display the icon bar.
2. Press the “Menu” button again to move to the next menu, or press the “Select” button to highlight the menu icon for the item you want to adjust. When an icon is highlighted, the name of the item appears on the right side of the icon menu bar.
3. Adjust the level or turn the selected item on or off by using the (+) or (-) buttons on the remote control or cabinet. The on-screen gauge will show you the amount of increase or decrease. [The (+) button is “on” and (-) is “off.”]
4. The change is stored until you adjust it again.
5. Repeat steps 2-4 to adjust an additional item, or press “Menu” on your remote control or cabinet to quit.

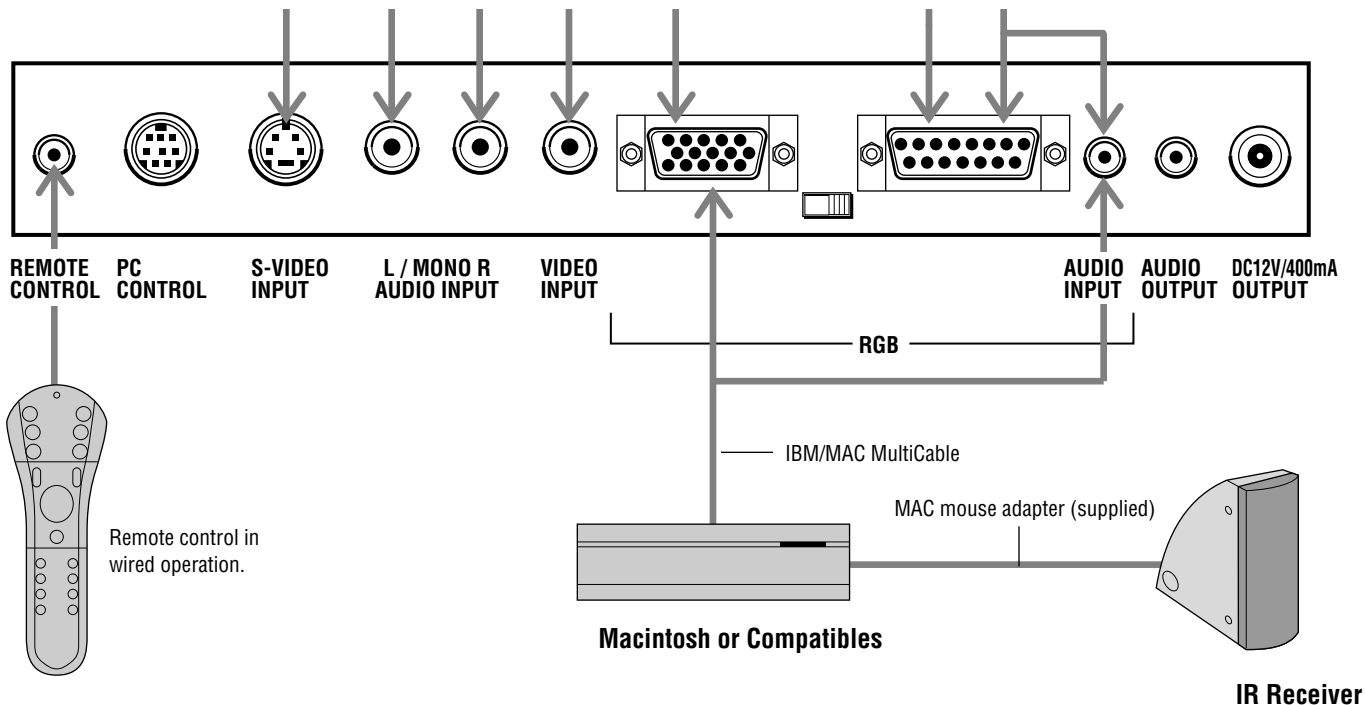
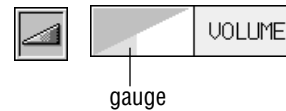

Connecting Your PC Or Macintosh Computer

Connecting your PC or Macintosh computer to your MultiSync MT600 LCD Projector will enable you to project your computer's screen image for an impressive presentation. All of these following display standards are supported:

VGA 640 x 480 for graphics, VGA 640 x 400 for graphics, VGA 640 x 350 for graphics, VGA 720 x 400 for text, VGA 720 x 350 for text, Macintosh at 640 x 480

To connect to a PC, Macintosh or computer equipped with a VGA adapter or compatible graphics adapter, simply:

1. Turn off the power to your LCD projector and computer.
2. If your PC does not support VGA you will need to install a VGA graphics board. Consult your computer's owner's manual for your VGA configuration. If you need to install a new board, see the manual that comes with your new graphics board for installation instructions.
3. Use the supplied MultiCable to connect your computer to the LCD projector. For a PC, use the smaller 15-pin connector on the cable to connect to your computer's video port; use the larger 15-pin connector on the cable to connect to the projector. For Macintosh, it's just the opposite. Use the larger 15-pin connector on the cable to connect to your computer's video port; use the smaller 15-pin connector on the

3. **Adjust The Image Size** Hold down the "Zoom" button on the remote control while pressing the left or right side of the mouse pad to make the image larger or smaller. You can also adjust the image size by holding down the "Menu" button on the projector cabinet and pressing the (+) or (-) button.
4. **Focus** Hold down the "Focus" button on the remote control while pressing the left or right side of the mouse pad to focus the image. You can also focus the image by holding down the "Select" button on the projector cabinet and pressing the (+) or (-) button.
5. **Turning Off The Projector** First press the "off" button on the remote control or the projector cabinet. The power light will glow amber. Allow the fan to cool the projector for a few minutes. This will extend the life of the lamp. Then turn off the main power switch on the back panel. The power light will go out.

IMPORTANT:

- The LCD projector should be unplugged if it will not to be used for an extended period.
- If you want to turn off the image briefly (five minutes or less), use the "Image Mute" feature instead of turning the projector off and on.
- The LCD projector will display a black image if no input signal is present.
- Do not turn the LCD projector off and then immediately back on. The Projector needs to cool down for a minute before it is powered on again.

This section describes how to select a computer or video source and how to adjust the picture and sound.

General Controls Before you turn on your MultiSync MT600 LCD Projector ensure that the computer or video source is turned on and that your lens cap is removed.

1. **Turn On The LCD Projector** The main power switch is on the back panel of the MultiSync MT600 LCD Projector. By turning this switch on, the projector will go into its standby mode and the power light will glow amber. Only after you press the “On” button on the remote control or projector cabinet will the power light turn to green and the projector become ready to use.

NOTE: To turn the LCD projector on and off with just the back panel switch, use the menu and enable the “auto start” feature. (See page 37.)

2. **Select The Computer Or Video Source** Press the “Video” (VCR or laser disc player), “S-video”, or “RGB” (computer or document camera) button on the remote control to display the image. Or press the “Menu” button on the cabinet and use the icons to select your video source: “Video,” “S-Video” or “RGB.”

cable to connect to the projector. (You can also use your own video cable if you wish.

For a PC cable, use the smaller 15-pin connector on the projector. For a Macintosh cable, use the larger 15-pin connector on the projector.)

4. Turn on the LCD projector and the computer.

NOTE: Refer to your computer’s owner’s manual for more information about your computer’s video output requirements and any special identification or configuring your projector’s image and monitor may require.

Connecting Your Document Camera

You can connect your MultiSync MT600 LCD Projector to a document camera. To do so, simply:

1. Turn off the power to your LCD projector and document camera.
2. Use the MultiCable provided or a standard video cable to connect to the 15-pin connector on your document camera to either of the two 15-pin connectors on the projector.
3. Turn on the LCD projector and the document camera.

NOTE: Refer to your document camera’s owner’s manual for more information about your camera’s video output requirements .

Connecting Your VCR Or Laser Disc Player

You use a common coaxial cable and RCA audio cables (not provided) to connect your VCR or laser disc player to your MultiSync MT600 LCD Projector. To make these connections, simply:

1. Turn off the power to your LCD projector and VCR or laser disc player.
2. Connect one end of your coaxial video cable to the video output connector on the back of your VCR or laser disc player, connect the other end to your projector. Use standard RCA audio patch cords to connect the audio from your VCR or laser disc player to your projector (if your VCR or laser disc player has this capability). Be careful to keep your right and left channel connections correct for stereo sound.
3. Turn on the LCD projector and the VCR or laser disc player.

***NOTE:** Refer to your VCR or laser disc player owner's manual for more information about your equipment's video output requirements.*

Connecting An External Monitor

You can connect a separate, external monitor to your LCD projector to simultaneously view on a monitor the image you're projecting. To do so:

1. Turn off the power to your LCD projector and computer, document camera or video source.
2. Use a 15-pin cable to connect your monitor to either available 15-pin connector on your LCD projector.
3. Turn the External Monitor Select Switch on the Terminal Panel to "on."
4. Turn on the LCD projector and the computer, document camera or video source.

Connecting Your IR Mouse Receiver

The IR Receiver enables you to operate your computer's mouse functions from the NEC MultiSync MT600 remote control. It is a great convenience for clicking through your computer-generated presentations.

To connect the IR Receiver:

1. Turn off your computer.
2. **For PCs:** Remove your current mouse and connect the serial cable from the IR Receiver to your PC's mouse port. (Use the 6-pin adapter for connecting to a PS/2 computer.)

For Macintosh: Remove your current mouse from your computer, attach the Macintosh adapter to the IR Receiver's serial cable, and connect the receiver to your mouse port.