



**LG**

Life's Good

# OWNER'S MANUAL DLP PROJECTOR

Please read this manual carefully before operating your set and retain it for future reference.

BX503  
BX403B

[www.lg.com](http://www.lg.com)

# DLP PROJECTOR



## Warning - Class B

(b) For a Class B Digital device or peripheral, the instructions furnished the user shall include the following or similar statement, placed in a prominent location in the text of the manual:

NOTE: This equipment has been tested and found to comply with the limits for a Class B digital device, pursuant to part 15 of the FCC Rules. These limits are designed to provide reasonable protection against harmful interference in a residential installation. This equipment generates, uses and can radiate radio frequency energy and, if not installed and used in accordance with the instructions, may cause harmful interference to radio communications. However, there is no guarantee that interference will not occur in a particular installation. If this equipment does cause harmful interference to radio or television reception, which can be determined by turning the equipment off and on, the user is encouraged to try to correct the interference by one or more of the following measures:

- Reorient or relocate the receiving antenna.
- Increase the separation between the equipment and receiver.
- Connect the equipment into an outlet on a circuit different from that to which the receiver is connected.
- Consult the dealer or an experienced radio/TV technician for help.

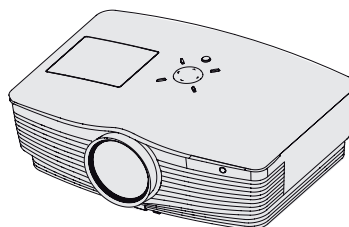

# Contents

<b>Safety Instructions</b> .....	4
<b>Names of parts</b>	
Main Body .....	7
Connecting Part .....	7
Control Panel.....	8
Remote Control .....	9
Installing Batteries.....	9
Projector Status Indicators .....	10
Accessories .....	11
Optional Extras.....	11
<b>Installing and Composition</b>	
Installation Instructions.....	12
Basic Operation of the Projector .....	13
Using Kensington Security System.....	14
Turning on the Projector .....	15
Turning off the Projector.....	15
Focus and Position of the Screen Image.....	16
Selecting source mode .....	16
<b>Connection</b>	
Connecting to a Desktop PC.....	17
Connecting to a Notebook PC.....	17
Connecting to a Video Source .....	18
Connecting to a DVD.....	18
Connecting to a D-TV Set-Top Box .....	18
<b>Function</b>	
<b>Video Menu Options</b>	
Adjusting Video .....	19
Picture mode.....	19
Color Temperature Control.....	20
Gamma Function.....	20
Gamma curve shift Function.....	20
Brilliant color™ Function .....	21
White peaking Function.....	21
Black level Function.....	21
Expert color Function .....	22
Reset.....	22
<b>Special Menu Options</b>	
Selecting Language .....	23
Using Aspect Ratio Function.....	23
Overscan Function .....	23
Flip horizontal Function .....	24
Flip vertical Function.....	24
Sleep time Function .....	24
Auto sleep Function .....	25
Presentation timer Function.....	25
Using Digital Zoom Function.....	26
Using Keystone Function .....	27
Using Blank Function .....	27
Selecting Blank image .....	28
Captured Image Function.....	28
Lamp mode Function .....	28
Using Monitor out Function .....	29
Checking lamp time.....	29
Using Still Function.....	29
<b>Screen Menu Options</b>	
Auto configure Function.....	30
Using Phase Function.....	30
Using Clock Function.....	30
Using Horizontal Function.....	31
Using Vertical Function.....	31
<b>RS-232C</b>	
External Control Device Setup.....	32
<b>Information</b>	
Supported Monitor Display.....	37
Maintenance .....	37
Replacing the Lamp.....	38
How to fix the lens cap to the projector.....	40
Specifications .....	41



## Disposal of your old appliance



1. When this crossed-out wheeled bin symbol is attached to a product it means the product is covered by the European Directive 2002/96/EC.
2. All electrical and electronic products should be disposed of separately from the municipal waste stream via designated collection facilities appointed by your government or your local authorities.
3. The correct disposal of your old appliance will help prevent potential negative consequences for the environment and human health.
4. For more detailed information about disposal of your old appliance, please contact your city office, waste disposal service or the shop where you purchased the product.
5. The fluorescent lamp used in this product contains a small amount of mercury. Do not dispose of this product with general household waste. Disposal of this product must be carried out in accordance to the regulations of your local authority.

# Safety Instructions

Please take note of the safety instructions to prevent any potential accident or misuse of the projector.

- Safety Instructions are given in two forms as detailed below.
-  **WARNING** : The violation of this instruction may cause serious injuries and even death.
-  **NOTES** : The violation of this instruction may cause injuries or damage to the projector.
- After reading this manual, keep it in the place that you can access easily.

## Indoor Installation WARNING

<p>Do not place the Projector in direct sunlight or near heat sources such as radiators, fires, stove etc.</p> <p>This may cause a fire hazard!</p>	<p>Do not place flammable materials in, on or near the projector.</p> <p>This may cause a fire hazard!</p>	<p>Do not hang on the installed projector.</p> <p>It may cause the projector to fall, causing injury or death.</p>
<p>Do not block the vents of the projector or restrict air-flow in any way.</p> <p>This would cause the internal temperature to increase and could cause a fire hazard or damage to the unit!</p>	<p>Do not place the projector close to sources of steam or oil such as a humidifier.</p> <p>This may create a fire hazard or an electric shock hazard!</p>	<p>Do not place the projector where it might be exposed to dust.</p> <p>This may cause a fire hazard or damage to the unit!</p>
<p>Do not use the projector in a damp place such as a bathroom where it is likely to get wet.</p> <p>This may cause a fire or an electric shock hazard!</p>	<p>Do not place the projector directly on a carpet, rug or place where ventilation is restricted.</p> <p>This would cause its internal temperature to increase and might create a fire hazard or damage the unit.</p>	<p>Ensure good ventilation around the projector. The distance between the projector and the wall should be more than 30 cm.</p> <p>An excessive increase in its internal temperature may cause a fire hazard or damage to the unit!</p>

## Indoor Installation NOTES

<p>When installing the projector on a table, be careful not to place it near the edge.</p> <p>The projector could fall causing injury and damage to the projector. <b>Only use a suitable stand.</b></p>	<p>Disconnect from the power supply and remove all connections before moving, or cleaning.</p>	<p>Only use the projector on a level and stable surface.</p> <p>It may fall and cause injury and/or damage to the unit.</p>
--	--	---

## Power WARNING

<p>Earth wire should be connected.</p> <p>Ensure that you connect the earth ground wire to prevent possible electric shock (That is a Projector with a three-prong grounded AC plug must be connected to a three-prong grounded AC outlet). If grounding methods are not possible, have a qualified electrician install a separate circuit breaker. Do not try to ground the unit by connecting it to telephone wires, lightning rods, or gas pipes.</p>	<p>The power cord should be inserted fully into the power outlet to avoid a fire hazard!</p> <p>This may cause a fire hazard or damage the unit.</p>	<p>Do not place heavy objects on the power cord.</p> <p>This may cause a fire or an electric shock hazard!</p>
--	--	--

Power	⚠ WARNING	
Never touch the power plug with a wet hand.  This may cause an electric shock hazard!	Do not plug-in too many items into one power outlet.  It may result in overheating of the outlet and create a fire hazard!	Prevent dust from collecting on the power plug pins or outlet.  This may cause a fire hazard!

Power	⚠ NOTES	
Hold the plug firmly when unplugging. If you pull the cord, it may be damaged.  This may cause a fire hazard!	Do not use if the power cord or the plug is damaged or any part of the power outlet is loose.  This may cause a fire or an electric shock hazard or damage to the unit!	Ensure the power cord does not come into contact with sharp or hot objects.  This may cause a fire or an electric shock hazard or damage to the unit!
Place the projector where people will not trip or tread on the power cord.  This may cause a fire or an electric shock hazard or damage to the unit!	Do not turn the projector On/Off by plugging-in or unplugging the power plug to the wall outlet. (Allow the unit to cool before removing power.)  It may cause mechanical failure or could cause an electric shock.	

Using	⚠ WARNING	
Do not place anything containing liquid on top of the projector such as flowerpot, cup, cosmetics or candle.  This may cause a fire hazard or damage to the unit!	In case of impact shock or damage to the projector switch it off and unplug it from the power outlet and contact an authorized service center.  This may cause a fire or an electric shock hazard or damage to the unit!	Do not allow any objects to fall into the projector.  This may cause an electric shock hazard or damage to the unit!
If water is spilt into the projector unplug it from the power supply immediately and consult your Service Agent.  This may cause an electric shock hazard or damage to the unit!		Dispose of used batteries carefully and safely.  In the case of a battery being swallowed by a child please consult a doctor immediately.
Do not remove any covers. High risk of Electric Shock!	Don't look directly into the lens when the projector is in use. Eye damage may occur!	Do not touch metal parts during or soon after operation since the vents will remain very hot!

**CAUTION concerning the Power Cord**

It is recommend that most appliances be placed on a dedicated circuit; that is, a single outlet circuit which powers only that appliance and has no additional outlets or branch circuits. Check the specification page of this owner's manual to be certain.

Do not overload wall outlets. Overloaded wall outlets, loose or damaged wall outlets, extension cords, frayed power cords, or damaged or cracked wire insulation are dangerous. Any of these conditions could result in electric shock or fire. Periodically examine the cord of your appliance, and if its appearance indicates damage or deterioration, unplug it, discontinue use of the appliance, and have the cord replaced with an exact replacement part by authorized service personnel.

Protect the power cord from physical or mechanical abuse, such as being twisted, kinked, pinched, closed in a door, or walked upon. Pay particular attention to plugs, wall outlets, and the point where the cord exits the appliance.

**Using**  **WARNING**

<p>If the projector is in a room that experiences a gas leak, do not touch the projector.</p> <p>It can cause a fire or a burn by a spark.</p>	<p>Always open the lens door or remove the lens cap when the projector lamp is on.</p>
--	--

**Using**  **NOTES**

<p>Do not place heavy objects on top of projector.</p> <p>This may cause mechanical failure or personal injury!</p>	<p>Take care not to impact the lens particularly when moving the projector.</p>	<p>Do not touch the lens of the projector. It is delicate and easily damaged.</p>
<p>Do not use any sharp tools on the projector as this will damage the casing.</p>	<p>In the event that an image does not appear on the screen please switch it off and unplug it from the power outlet and contact your Service Agent.</p> <p>This may cause a fire or an electric shock hazard or damage to the unit!</p>	<p>Do not drop the projector or allow impact shock.</p> <p>This may cause mechanical failure or personal injury!</p>

**Cleaning**  **WARNING**

<p>Do not use water while cleaning the projector.</p> <p>This may cause damage to the projector or an electric shock hazard.</p>	<p>In the unlikely event of smoke or a strange smell from the projector, switch it off, unplug it from the wall outlet and contact your dealer or service center.</p> <p>This may cause a fire or an electric shock hazard or damage to the unit!</p>	<p>Use an air spray or soft cloth that is moist with a neutral detergent and water for removing dust or stains on the projection lens.</p>
--	---	--

**Cleaning**  **NOTES**

<p>Contact the Service Center once a year to clean the internal parts of the projector.</p> <p>Accumulated dust can cause mechanical failure.</p>	<p>When cleaning the plastic parts such as projector case, unplug the power and wipe it with a soft cloth. Do not use cleanser, spray water or wipe with a wet cloth. Especially, never use cleanser (glass cleaner), automobile or industrial shiner, abrasive or wax, benzene, alcohol etc., which can damage the product. Use an air spray or soft cloth that is moist with a neutral detergent and water for removing dust or stains on the projection lens.</p> <p>It can cause fire, electric shock or product damage (deformation, corrosion and damage).</p>
---	--

**Others**  **WARNING**

Do not attempt to service the projector yourself. Contact your dealer or service center.

This may cause damage to the projector and could give an electric Shock as well as invalidating the warranty!

**Others**  **NOTES**

<p>Do not mix new batteries with old batteries.</p> <p>This may cause the batteries to over-heat and leak.</p>	<p>Be sure to unplug if the projector is not to be used for a long period.</p> <p>Accumulated dust may cause a fire hazard or damage to the unit!</p>	<p>Only use the specified type of battery.</p> <p>This could cause damage to the remote control.</p>
--	---	--

# Names of parts

## Main Body

\* The projector is manufactured using high-precision technology. You may, however, see on the Projector screen tiny black points and/or bright points (red, blue, or green). This can be a normal result of the manufacturing process and does not always indicate a malfunction.

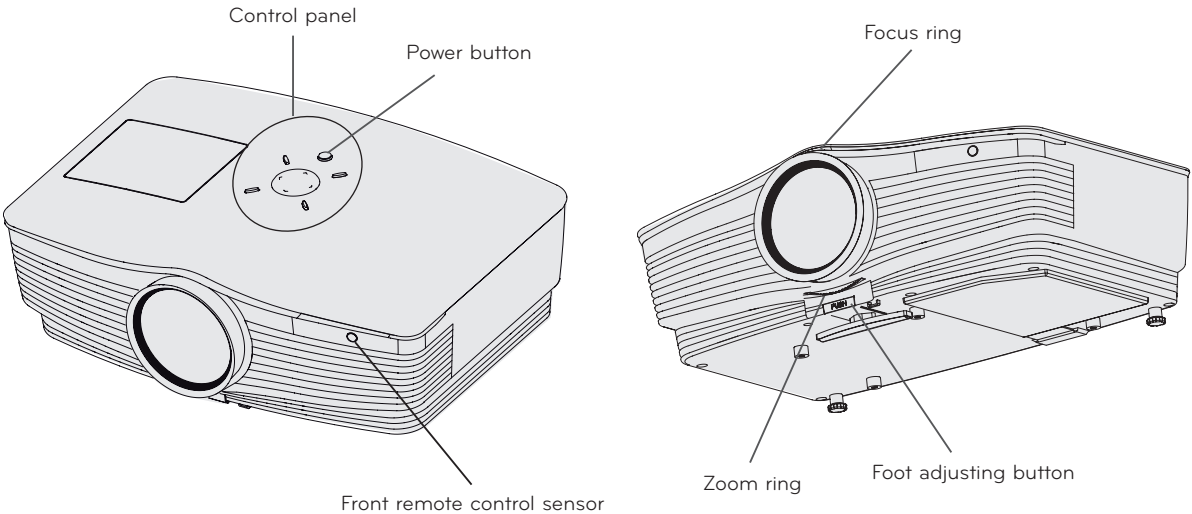

## Control Panel

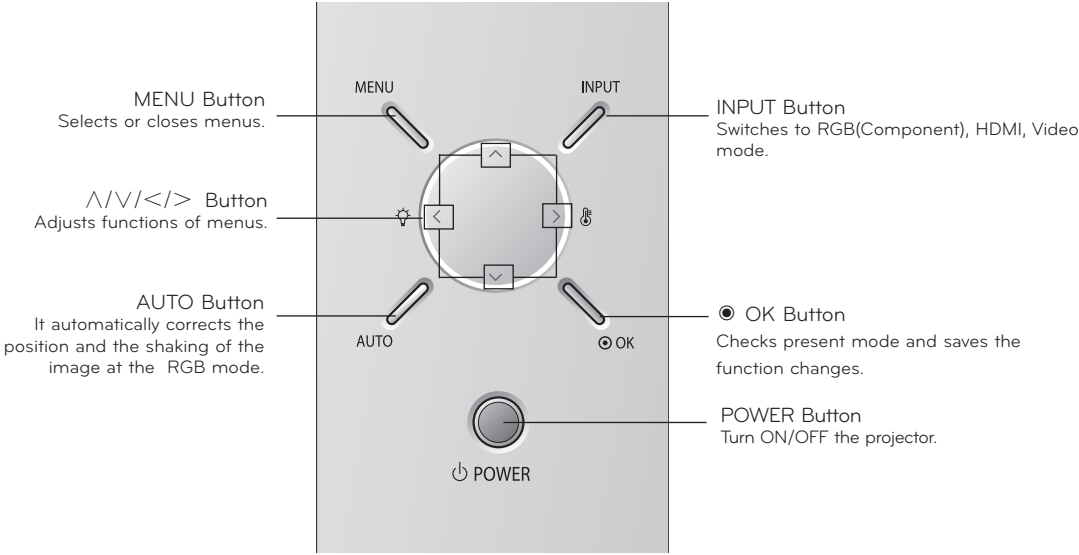

Connecting Part

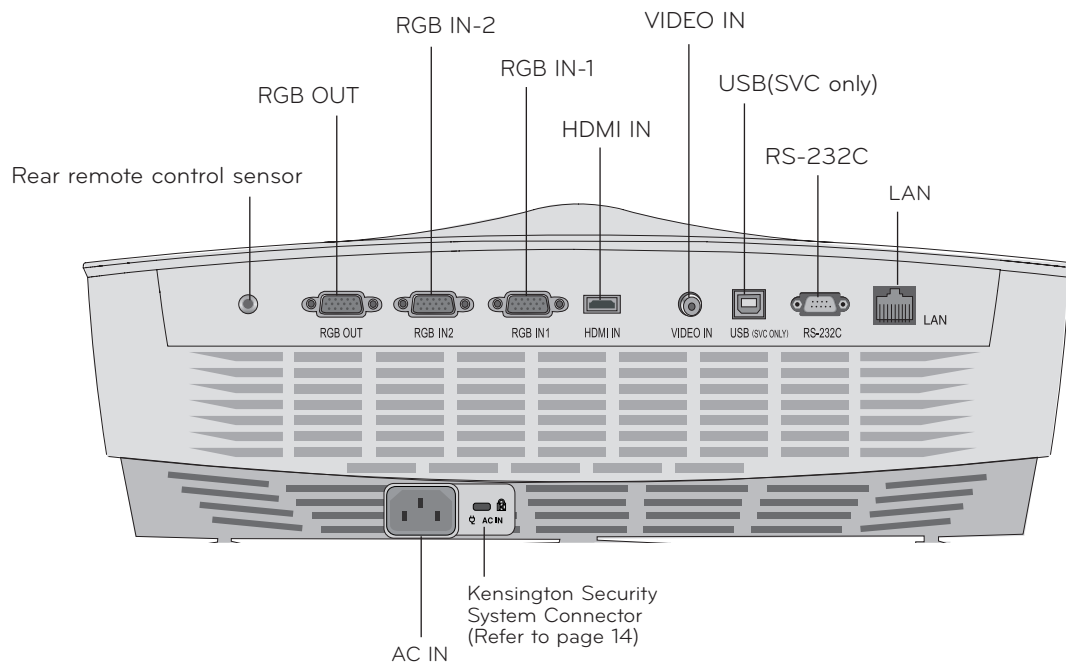



Remote Control

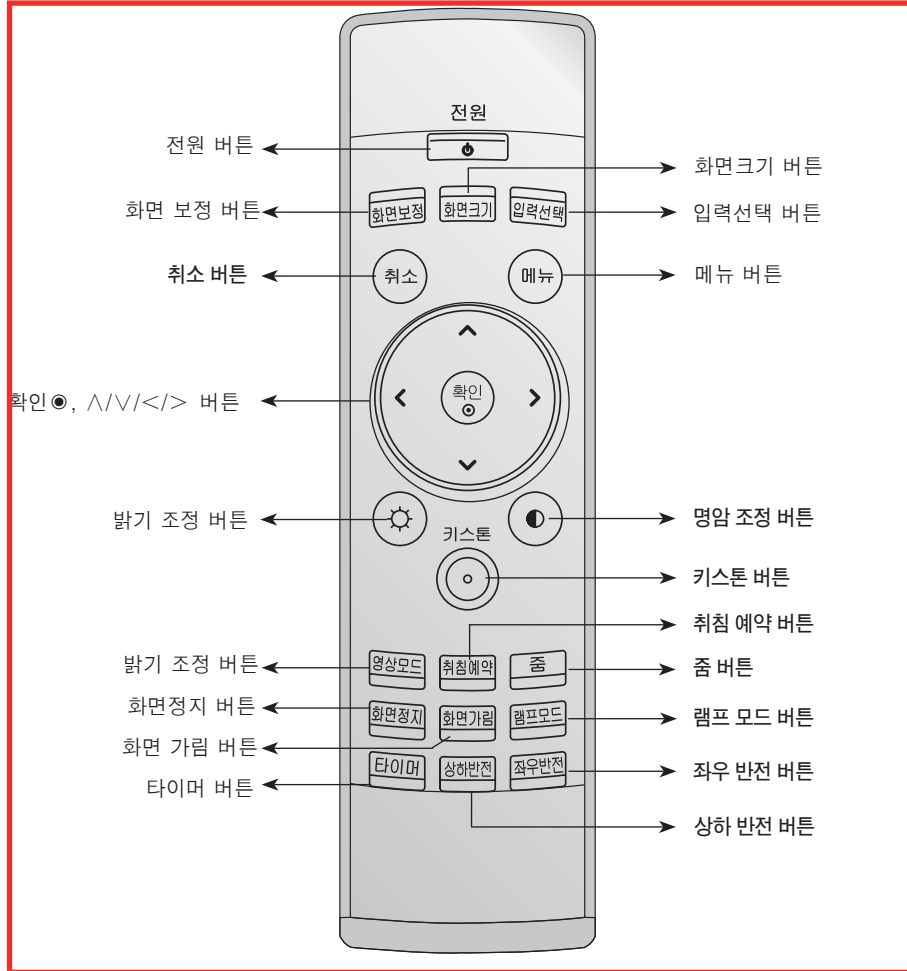

Installing Batteries

**CAUTION**

RISK OF EXPLOSION IF BATTERY IS REPLACED WITH AN INCORRECT TYPE.  
DISPOSE OF USED BATTERIES ACCORDING TO THE INSTRUCTIONS.

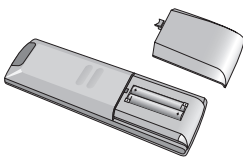

- Open the battery compartment cover on the back of the remote control.
- Insert the specified type of batteries with correct polarity, match "+" with "+", and match "-" with "-".
- Install two 1.5V AAA batteries. Don't mix used batteries with new batteries.

## Projector Status Indicators

\* Lamp indicator, operation indicator and temperature indicator at the top of the projector show the user the operating status of the projector.

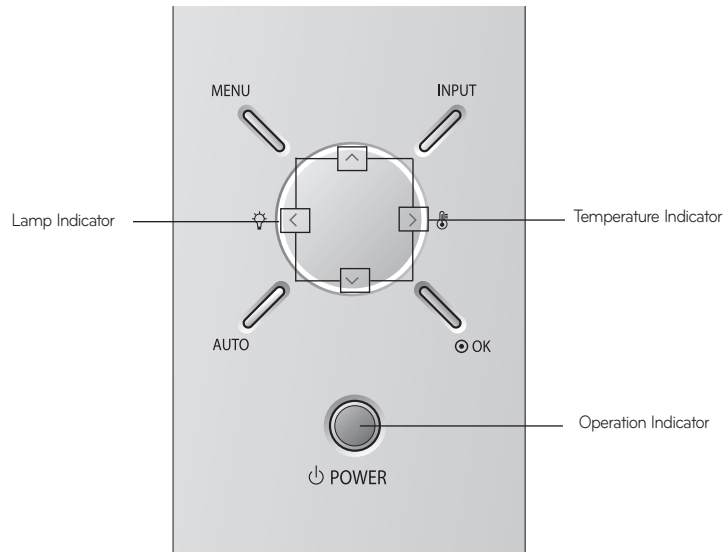

Operation Indicator	Red	Standby.
	Green(flashing)	Lamp is starting up.
	Green	Unit is in operation (Lamp is turned on)
	Orange(flashing)	Projector lamp is cooling (20 sec.)
	Off	Power off.
	Orange	Standby-This mode cools the projector naturally for 4 minutes after it is turned off.
	Red(flashing)	This indicates a Colour Wheel problem. Please contact your local service centre.
Lamp Indicator	Red	Projector lamp is reaching the end of its life and needs to be replaced with a new lamp.
	Red(flashing)	The projector is experiencing an error. Retry Power On again later. If lamp indicator is red (flashing) again, contact the service center.
	Green(flashing)	The lamp cover is open.
Temperature Indicator	Orange	A high temperature state has been detected. Turn the Projector off.
	Red	The Projector has turned off due to excessive heat.
	Red (flashing)	Power has turned off due to problem with the internal cooling fan. Contact your service center.

Accessories



Remote Control

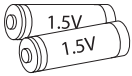

AAA Battery

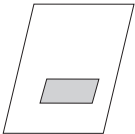

Owner's manual



Power Cord



Computer Cable



Lens cap and Strap



ez-net Program CD

Optional Extras

- \* Contact your dealer to purchase these items.
- \* Contact your service personnel for replacing of lamp.
- \* The lamp is consumable and needs to be replaced with a new one when it is burned out.
- \* Optional parts can be changed without notice to improve the quality of the product, and new optional parts can be added.

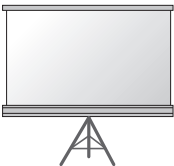

Projection Screen

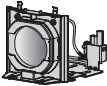

Lamp



LAN Cable



Component Cable



HDMI Cable



RS-232C Cable



RCA to D-Sub Adapter



Video Cable



HDMI to DVI Cable

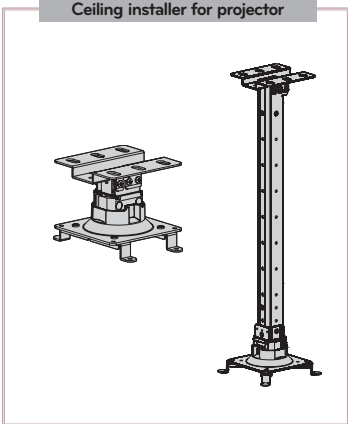

# Installing and Composition

## Installation Instructions

\* Don't place the projector in the following conditions. It may cause malfunction or product damage.

### Provide proper ventilation for this projector.

The projector is equipped with ventilation holes(intake) on the bottom and ventilation holes(exhaust) on the front. Do not block or place anything near these holes, or internal heat build-up may occur, causing picture degradation or damage to the projector.

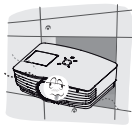

Never push projector or spill any kind of liquid into the projector.



Do not place the projector on a carpet, rug or other similar surface. It may prevent a adequate ventilation of the projector bottom. This product should be mounted to a wall or ceiling only.



Leave an adequate distance(30cm/12 inches or more) around the projector.

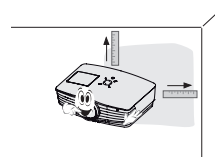

### Place this projector in adequate temperature and humidity conditions.

Install this projector only in a location where adequate temperature and humidity is available. (refer p.41)

### Don't place the projector where it can be covered with dust.

This may cause overheating of the projector.

### Do not obstruct the slots and openings of the projector. This may cause overheating and create a fire hazard.

### The projector is manufactured using high-precision technology. You may, however, see tiny black points and/or bright points (red, blue, or green) that continuously appear on the projector Screen. This is a normal result of the manufacturing process and does not indicate a malfunction.

### To display DTV programs, it is necessary to purchase a DTV receiver (Set-top Box) and connect it to the projector.

### When the remote control does not work during operation.

The remote control may not work when a lamp equipped with electronic ballast or a three-wavelength lamp is installed. Replace those lamps with international standard products to use the remote control normally.

Basic Operation of the Projector

1. Place the projector on a sturdy and horizontal surface with the PC or AV source.
2. Place the projector with the desired distance from the screen. The distance between the projector and the screen determines the actual size of the image.
3. Position the projector so that the lens is set at a right angle to the screen. If the projector is not set at a right angle, the screen image will be crooked. If this is so then the keystone adjustment may correct this (Refer to page 27).
4. Connect the cables of the projector to a wall power socket and other connected sources.

projection distance based on the picture format

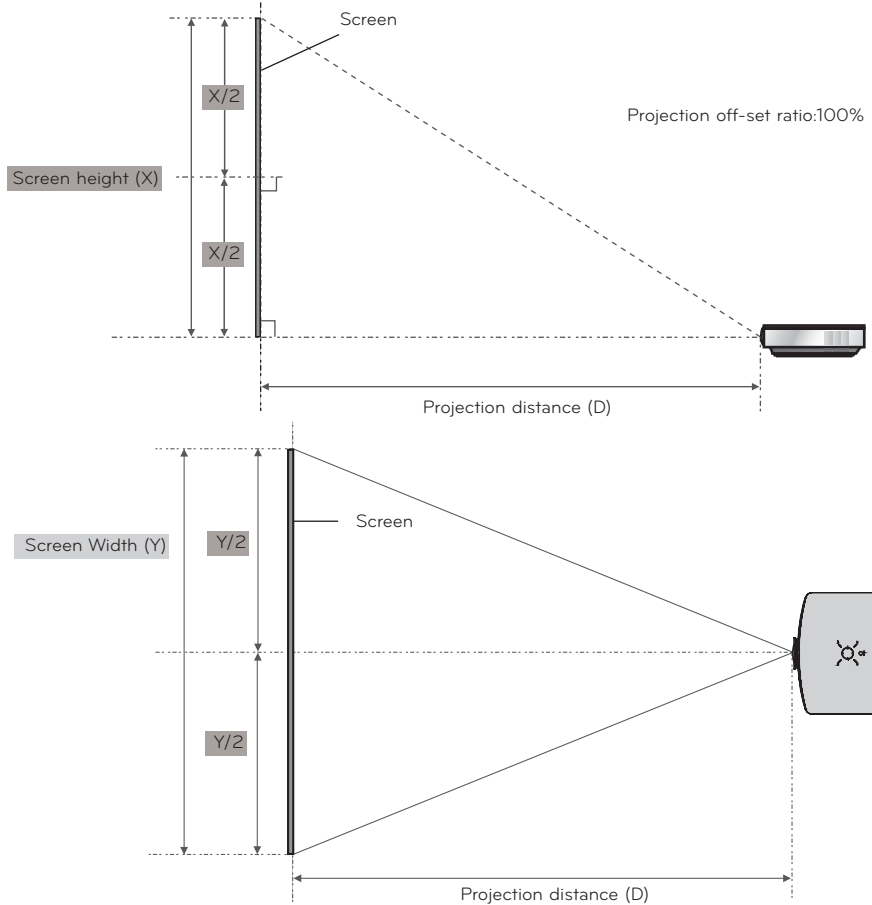

4 : 3 Scale			Projection Distance	
Diagonal Size (mm)	Horizontal Size (mm)	Vertical Size (mm)	Wide Distance (mm)	Tele Distance (mm)
1016	813	610	1000	1198
1270	1016	762	1250	1497
1524	1219	914	1500	1796
1778	1422	1067	1750	2095
2032	1626	1219	2000	2395
2286	1829	1372	2250	2694
2540	2032	1524	2500	2994
3048	2438	1829	3000	3593
3556	2845	2134	3500	4192
4064	3251	2438	4000	4791
4572	3658	2743	4500	5390
5080	4064	3048	5000	5989
5588	4470	3353	5500	6588
6096	4877	3658	6000	7187
6604	5283	3962	6500	7486
7112	5690	4267	7000	7786
7620	6096	4572	7500	8684

\* The longest/shortest distance show status when adjusted by the zoom function.

### Using Kensington Security System

- The projector has a 'Kensington' Security System Connector on the side panel. Connect the 'Kensington' Security System cable as below.
- For the detailed installation and use of the Kensington Security System, refer to the user's guide attached to the Kensington Security System set.
- And for further information, contact <http://www.kensington.com>, the internet homepage of the Kensington company that deals with expensive electronic equipment such as notebook PCs or projectors.
- Kensington Security System is an optional item.

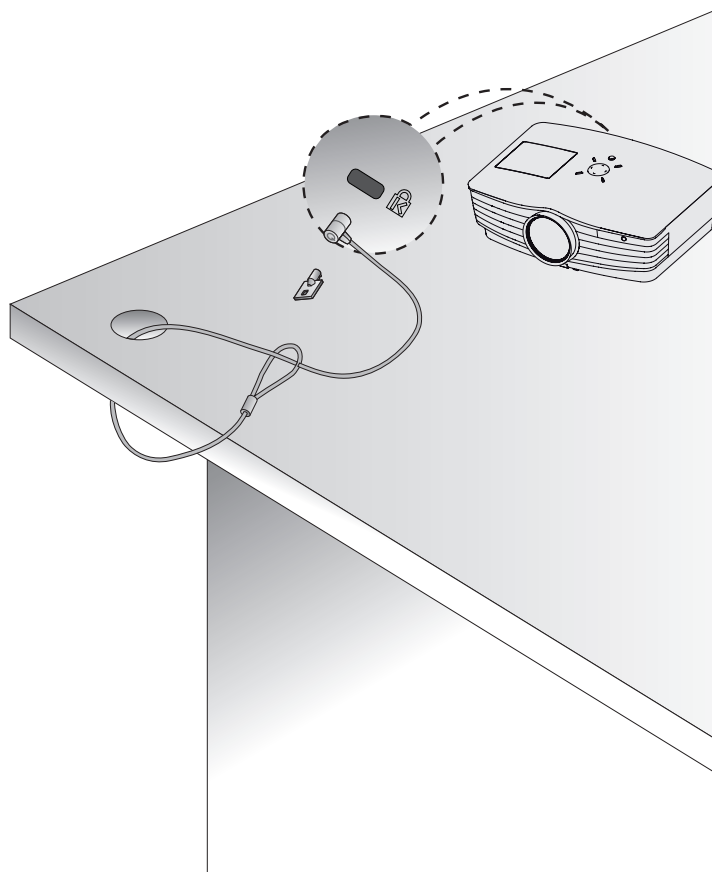

## Turning on the Projector

1. Connect power cord correctly.
2. Remove the lens cap. If it is left on, it could become deformed due to the heat produced by the projection lamp.
3. Press the **POWER** button on the remote control or top cover. (Green operation indicator flashes if lamp is in start-up cycle.)
  - An image will appear after the operation indicator light turns (Green).
  - Select the source mode with the INPUT button.

### Note!

\* Do not disconnect the power cord during the suction/discharge fan in operation. If the power cord is disconnected during the suction/ discharge fan in operation, it may take longer to activate the lamp after turning on the power and the lifespan of the lamp may be shortened.

## Turning off the Projector

1. Press the **POWER** button on the top cover or remote control.
2. Press the **POWER** button on the top cover or remote control again to turn off the power.
3. If the operation indicator LED is orange and blinking, do not disconnect (20 sec.) the supply until the operation indicator LED is lit constantly (orange).
  - If the operation indicator LED is orange and blinking, the power button on the top cover or on the remote control will not operate.
  - This projector features the Quick Power On/Off function that allows a user to turn it on and off quickly.



\* What is the Quick Power On/Off function?

The projector enters into Standby mode without waiting it is cooled.  
If Standby mode continues for a certain amount of time, the projector can operate without cooling when it is turned on.

### Focus and Position of the Screen Image

When an image appears on the screen, check if it is in focus and fits well to the screen.

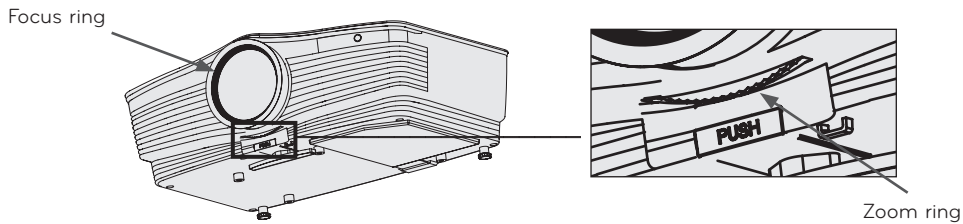

- To adjust the focus of the image, rotate the focus ring which is the outer ring on the lens.
- To adjust the size of the image, rotate the zoom ring which is the inner ring on the lens.

To raise or lower the image on the screen, extend or retract the foot at the bottom of the projector by pushing foot adjusting button as below.

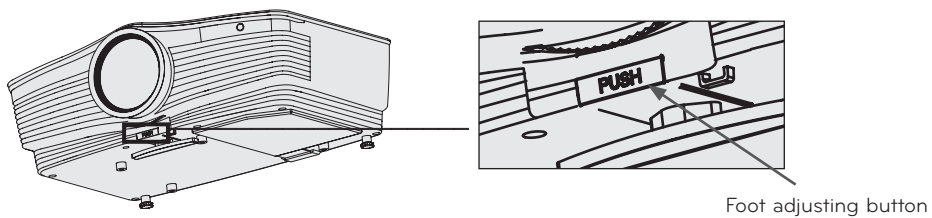

1. While pressing the foot adjusting button, raise or lower the projector to place the screen image in the proper position.
2. Release the button to lock the foot in its new position.
3. Turn the foot at the back left or right to make a fine tune of the length of the projector.  
After raising the front foot, do not press down on the projector.

### Selecting source mode

1. Press the **INPUT** button on the remote control or the control panel.

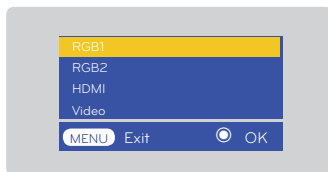

2. After moving into desiring input by pressing  $\wedge$ ,  $\vee$  button, please press the confirm button.

- When a signal cable is plugged in and there 's a signal, the selecting item is activated as white, and if there 's no signal, the selecting item is deactivated as gray.
- If pressing the input selection button, it is possible to select activated item.
- It is possible to watch by selecting RGB 1 for Component 1 input and RGB 2 for Component 2 input, and in case of Component, even though there 's an input signal, the OSD item is not activated.



# Connection

## Connecting to a Desktop PC

- You can connect the projector to a computer of VGA, SVGA, XGA and SXGA output.
- Refer to page 40 for the supported monitor displays of the projector.
- You can select an RGB input from the Monitor Out menu that will be output to RGB OUT(RGB1 or RGB2).

### <To use by connecting to RGB>

Connect the **RGB IN 1** of the projector and the computer output port with computer cable.

- You can also connect to the **RGB IN 2** port.

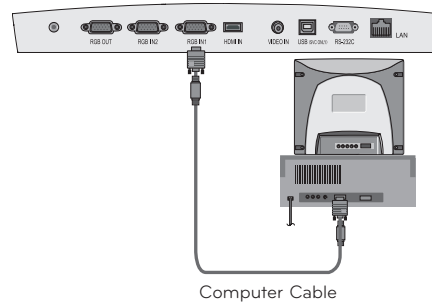

### <To use by connecting to HDMI terminal>

Please connect projector 's **HDMI IN** terminal and computer 's output terminal by using **HDMI to DVI** cable.

- You can also connect to the **RGB IN 2** port.

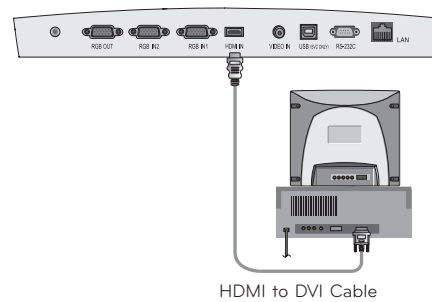

## Connecting to a Notebook PC

### < How to connect >

Connect the **RGB IN 1** of the projector and the computer output port with computer cable.

- If you set your computer to output the signal to both the display of your computer and the external projector, the picture of the external projector may not appear properly. In such cases, set the output mode of your computer to output the signal only to the external projector. For details, refer to the operating instructions supplied with your computer.
- You can also connect to the **RGB IN 2** port.

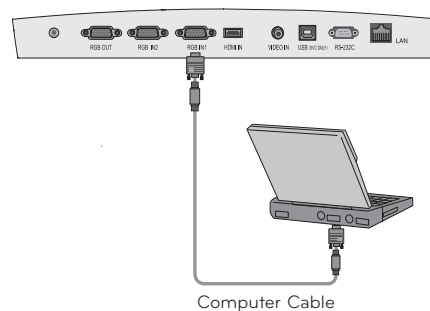

## Connecting to a Video Source

- You can connect a VCR, a camcorder or any other compatible video image source to the projector.

### < How to connect >

Connect the Video input jacks of the projector to the output jacks of the A/V source with Video cable.

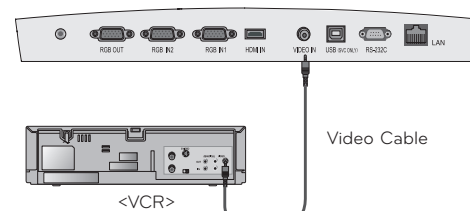

### Connecting to a DVD

\* The output jacks (Y, Pb, Pr) of the DVD might be labeled as Y, Pb, Pr / Y, B-Y, R-Y / Y, Cb, Cr according to the equipment.

#### < How to connect >

- a. Connect the DVD Component cable to the **RCA to D-Sub Adapter** and then connect the **RCA to D-Sub Adapter** to **RGB IN 1** of the projector.

\* When connecting the component cable, match the jack colors with the component cable.(Y=green, Pb=blue, Pr=red)

\* You can also connect to the **RGB IN 2** port.

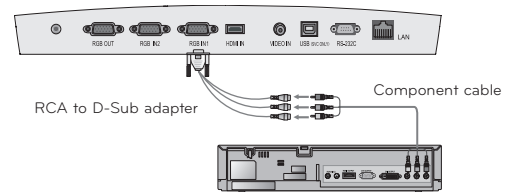

Signal	Component	HDMI/DVI
480i	○	X
480p	○	○
720p	○	○
1080i	○	○
576i	○	X
576p	○	○
1080p (24,30Hz)	○	○

### Connecting to a D-TV Set-Top Box

\* To receive D-TV programmes, it is necessary to purchase a D-TV receiver (Set-Top Box) and connect it to the projector.  
 \* Please refer to the owner's manual of the D-TV Set-Top Box for the connection between projector and D-TV Set-Top Box.

#### < How to connect a HDMI source >

- a. Connect the **HDMI IN** terminal of the projector to the **HDMI** output terminal of the D-TV Set-Top Box via HDMI cable.

- b. Use a DTV receiver with DTV 480p(576p)/720p/1080i(24,30Hz) mode.  
 \* No support of audio.

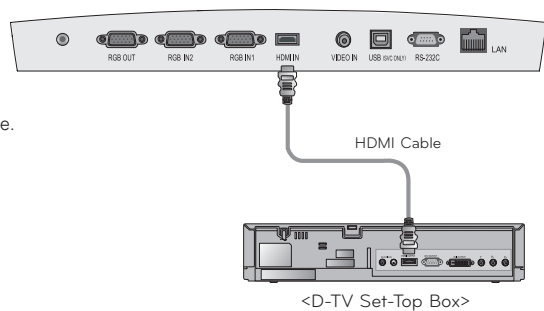

#### < How to connect a Component source >

- a. Connect the D-TV Set-Top Box Component cable to the **RCA to D-Sub Adapter** and then connect the **RCA to D-Sub Adapter** to **RGB IN 1** of the projector.

\* When connecting the component cable, match the jack colors with the component cable.(Y=green, Pb=blue, Pr=red)

\* You can also connect to the RGB IN 2 port.

\* No support of audio.

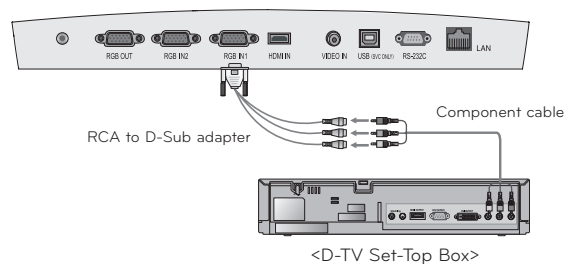

## Function

\* In this manual, the OSD(On Screen Display) may be different from your Projector's because it is just an example to help with the Projector operation.

\* This operating guide explains operation of RGB(PC) mode mainly.

## Video Menu Options

### Adjusting Video

1. Press the **MENU** button and then use <, > button to select the  menu.
2. Press the ^, v button to select a video item you want to adjust.
3. Press the <, > button to adjust the screen condition as you want.

\* Each adjustment of  menu options will not affect other inputs.

\* 색상 항목은 컴포넌트 60Hz, 외부입력 또는 NTSC 신호에 대해서만 항목이 표시되고 조정이 가능합니다.

\* You can adjust contrast by pressing the  button on the remote control.

\* You can adjust brightness by pressing the  button on the remote control.

\* Press the **MENU** button twice or the **EXIT** button to exit the menu screen.

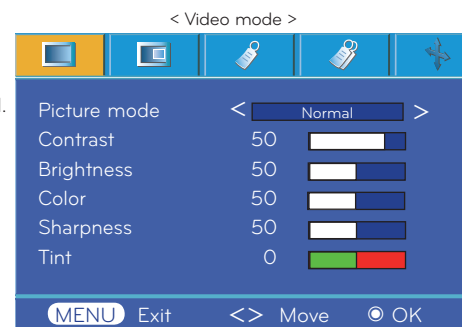
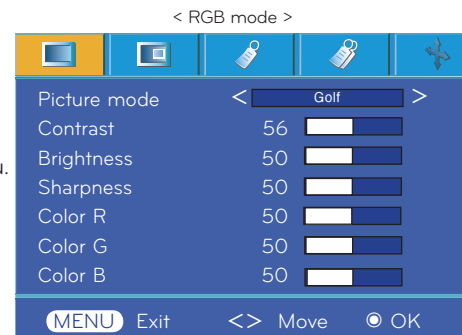

### Picture mode

\* Use Picture mode function to set the projector for the best picture appearance.

1. Press the **MODE** button on the remote control.
2. Press the <, > button to adjust the screen condition as you want.

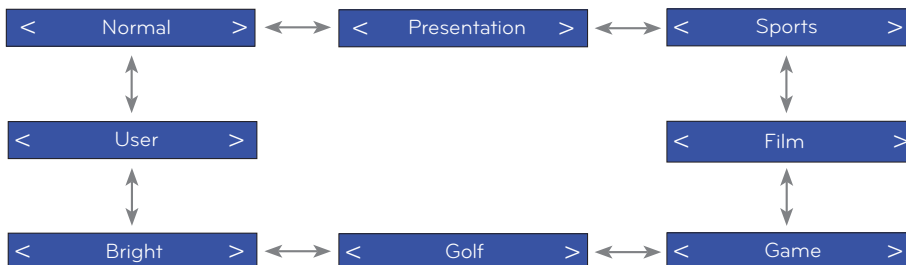

\* You can use this function through the **MENU** button.

\* To exit the menu display, press the **EXIT** button.

### Color Temperature Control

- To initialize values (reset to default settings), select the **Natural** option.

1. Press the **MENU** button and then use <, > button to select the  menu.
2. Press the  $\wedge, \vee$  button to select **Color temp.** item.
3. Press the <, > button to make desired adjustments.

\* Each press of the <, > button changes the screen as shown below.



- \* This function can be inactivated depends on the Picture mode. When the Picture mode is set in Bright or Golf, you can't adjust Color temperature function.
- \* Press the **MENU** button twice or the **EXIT** button to exit the menu screen.

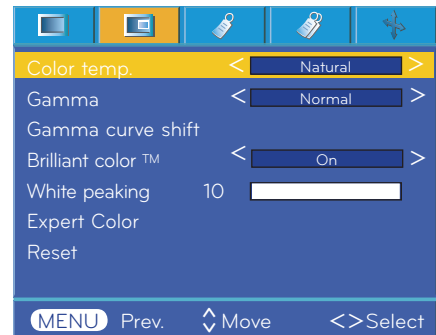

### Gamma Function

1. Press the **GAMMA** button on the remote control.
2. Press the <, > button to select the screen condition you want.

\* Each press of the <, > button changes the screen as shown below.



- \* You can use this function through the **MENU** button.
- \* To exit the menu display, press the **EXIT** button.

### Gamma curve shift Function

- This function shifts the gamma curves for Red, Green and Blue individually to adjust brightness.

1. Press the **MENU** button and then use <, > button to select the  menu.
2. Press the  $\wedge, \vee$  button to select **Gamma curve shift** item.
3. Press the **OK** button.
4. When the window below appears, press  $\wedge, \vee$  button to move between the items and the <, > buttons to adjust the screen as you want.

- \* Gamma curve shift Red, Green, Blue can be adjusted between -20 and 20.
- \* Press the **MENU** button twice or the **EXIT** button to exit the menu screen.

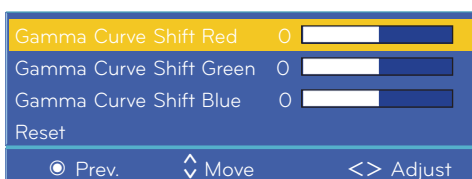
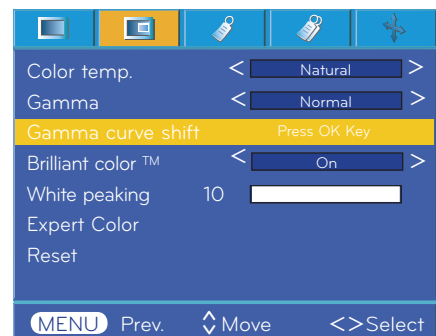

### Brilliant color™ Function

1. Press the **MENU** button and then use <, > button to select the  menu
2. Press the ^, v button to select **Brilliant color™** item.
3. Press the <, > button to select On or Off.

\* Press the **MENU** button twice or the **EXIT** button to exit the menu screen.

\* What is the **Brilliant color™** function?

This function increases the entire brightness of the screen or decreases it a little to make the rich grayscale color.

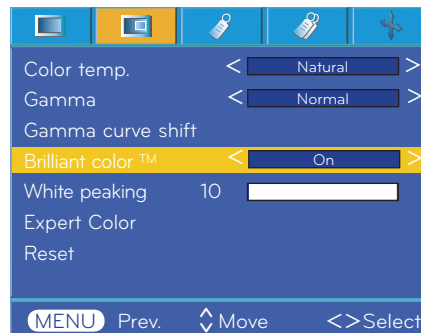

### White peaking Function

1. Press the **W.PEAK** button on the remote control.
2. Press the <, > button to select the screen condition you want.

\* The default value may change depending on input mode.

\* **White peaking** can be adjusted from 0 to 10.

\* Adjust to higher setting to achieve brighter picture. Adjust to lower setting for darker picture.

\* You can use this function through the **MENU** button.

\* To exit the menu display press the **EXIT** button.

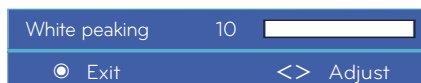

### Black level Function

1. Press the **MENU** button and then use <, > button to select the  menu
2. Press the ^, v button to select **Black level** item.
3. Press the <, > button to select Low or High.

\* This function works in the following mode : HDMI(Only activates in DTV signal), Video

\* To exit the menu display, repeatedly press the **MENU** button.

\* What is the **Black level** function?

When you watch the movie, this function adjusts the set to the best picture appearance. Adjusting the contrast and the brightness of the screen using the black level of the screen.

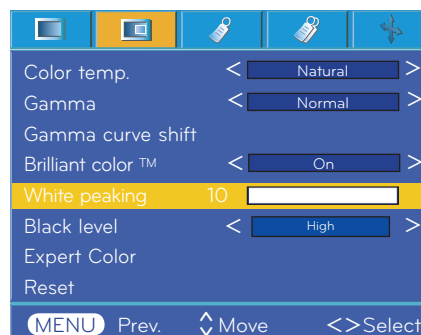

### Expert color Function

- This function allows a user to adjust the Gain, Saturation and Hue for Red, Green, Blue, Cyan, Magenta and Yellow individually.

1. Press the **MENU** button and then use <, > button to select the  menu.
2. Press the ^, v button to select **Expert Color** item.
3. Press the **OK** button.

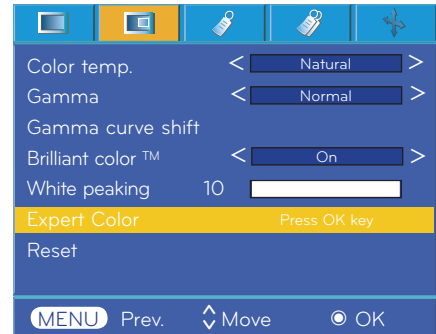
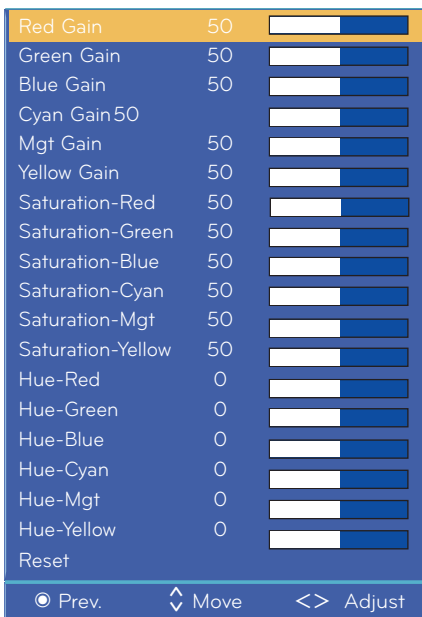

4. When the window above appears, press <, > button.



5. Press the ^, v button to move between the items and the <, > buttons to adjust the screen as you want.

- ! Red, Green, Blue, Cyan, Magenta and Yellow Gain can be adjusted between 0 and 100.
- ! Saturation-Red, Green, Blue, Cyan, Magenta and Yellow can be adjusted between 0 and 100.
- ! Hue-Red, Green, Blue, Cyan, Magenta and Yellow can be adjusted between -50 and 50.
- ! Press the **MENU** button twice or the **EXIT** button to exit the menu screen.
- ! An advanced settings function is possible to be saved according to an image mode.

### Reset

- ! To return to the factory default settings, select [**Reset**] with ^, v buttons and press **OK** button.

## Special Menu Options

### Selecting Language

1. Press the **MENU** button and then use <, > button to select the  menu.
2. Press the ^, v button to select **Language** item.
3. Press the <, > button to select the language you want to use.
  - † On-Screen-Display (OSD) is displayed in the selected language.
  - † Press the **MENU** button twice or the **EXIT** button to exit the menu screen.

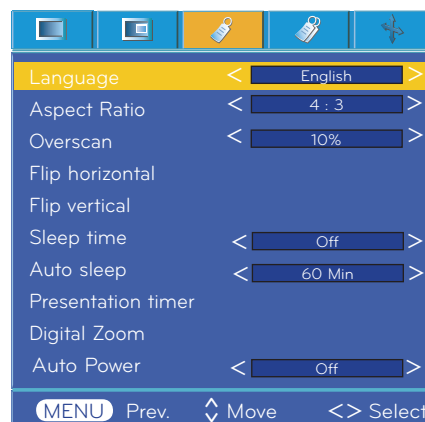

### Using ARC Function

1. Press the **RATIO** button.  
Each press of the button changes the display as below.

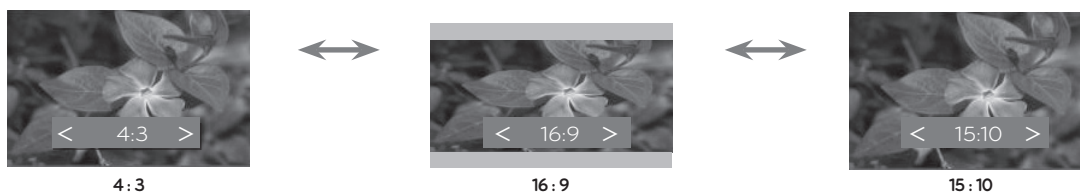

- \* You can also use this function by using the **MENU** button.

### Overscan Function

1. Press the **MENU** button and then use <, > button to select the  menu.
2. Press the ^, v button to select **Overscan** item.
3. Press the <, > buttons.
  - † The **Overscan** function can be adjusted only in RGB, HDMI and Component modes.
  - † The **Overscan** function can be adjusted between Off and 10%.
  - † The **Overscan** function can not be adjusted if the Zoom +/- in Digital Zoom is set to a value other than 100%.
  - † Press the **MENU** button twice or the **EXIT** button to exit the menu screen.

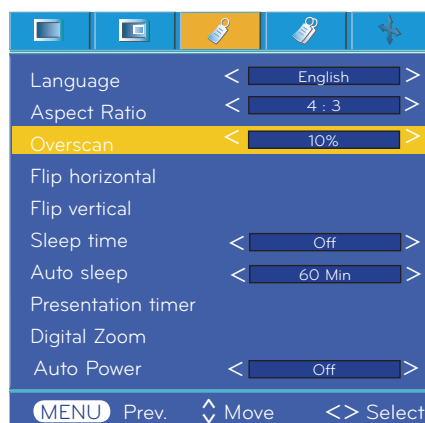

### Flip horizontal Function

\* This function reverses the projected image horizontally.  
Use this function when rear projecting an image.

1. Press the **MENU** button and then use <, > button to select the  menu.
2. Press the ^, v button to select **Flip horizontal** item.
3. Press the **OK** button to see reversed image.

- † Each time you press the **OK** button, the image will be reversed.
- † Press the **MENU** button twice or the **EXIT** button to exit the menu screen.

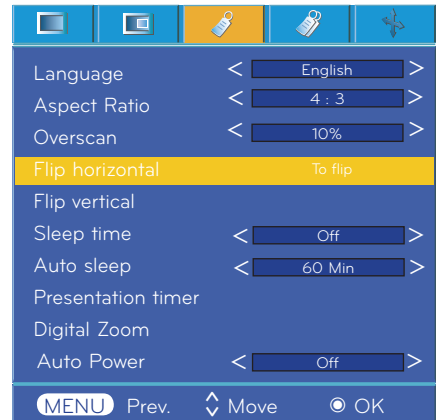

### Flip vertical Function

\* This function reverses the projected image vertically.  
\* When you hang the projector upside down from the ceiling, you will need to reverse the image vertically and horizontally.

1. Press the **MENU** button and then use <, > button to select the  menu.
2. Press the ^, v button to select **Flip vertical** item.
3. Press the **OK** button to see reversed image.

- † Each time you press the **OK** button, the image will be reversed.
- † Press the **MENU** button twice or the **EXIT** button to exit the menu screen.

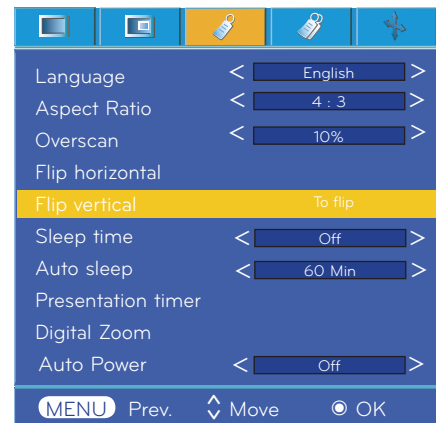

### Sleep time Function

\* The sleep timer turns the projector off at the preset time.

1. Press the **SLEEP** button of remote control.
2. Press the <, > button to select the desired preset time.

† Each press of the <, > button changes the screen as shown below.

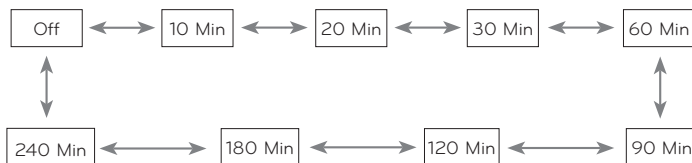

- † You can use this function through the **MENU** button.
- † To exit the menu display press the **EXIT** button.



### Auto sleep Function

\* This function turns the projector off automatically after the preset time is passed when there is no signal.

1. Press the **MENU** button and then use <, > button to select the  menu.
2. Press the  $\wedge, \vee$  button to select **Auto sleep** item.
3. Press the <, > button to select the desired preset time.

‡ Press the **MENU** button twice or the **EXIT** button to exit the menu screen.

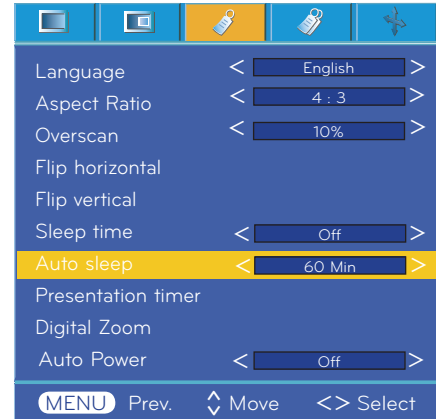
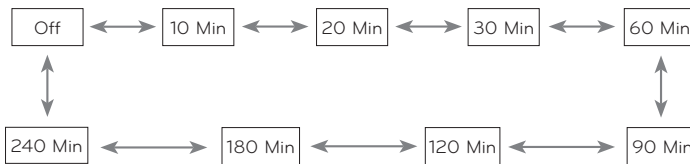

### Presentation timer Function

1. Press the **TIMER** button of remote control.
2. Press the  $\wedge, \vee$  button to select **Time alarm** or **Time keeper** item.

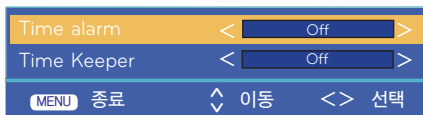

3. Press the <, > button to select the desired preset time.
4. The timer starts to operate if you select specific time.

- ‡ Time alarm function : If you select a specific time, it is displayed in minute units. After 1 minute, the remaining time is displayed at the bottom right of the screen, and then disappears after 5 seconds. When the remaining time is displayed, other OSD windows are closed. When the set time is reached, '0 minute' flickers 10 times at 1 second intervals, and then disappears.
- ‡ Time keeper function : If you select a specific time, it continues to be displayed in minute(') and second(") units. Even though other OSD windows appear, the remaining time is displayed again after the windows are closed. When the set time is reached, '0' 00" flickers 10 times at 1 second intervals, and then disappears.

5. If the set time disappears because of the use of other menus, press the **TIMER** button on a remote to display the set time again.
  - ‡ The **Time alarm** function and the **Time keeper** function cannot be used at the same time.
  - ‡ The **Time alarm** function can be set from 5 to 60 minutes at 5 minute intervals (Off, 5, 10, 15, 20, ..... 55, 60 minutes).
  - ‡ The **Time keeper** function can be set from 1 to 10 minutes at 1 minute intervals, and from 10 to 60 minutes at 5 minute intervals (Off, 1, 2, 3, 4, ..... 8, 9, 10, 15, 20, 25, ..... 55, 60 minutes).
  - ‡ You can use this function through the **MENU** button.
  - ‡ Press the **EXIT** button to exit the menu screen.

### Using Digital Zoom Function

\* This function is available only in RGB input mode. The Zoom +/- and Position values return to their default when you change the SOURCE or input signal, or turn the power off.

#### Adjusting the Zoom

1. Press the **ZOOM** button on the remote control.
2. Press the  $\wedge, \vee$  button to select **Zoom +/-** item.

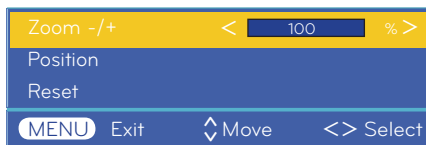

3. Press the  $<, >$  button to adjust Zoom +/- to your choice.
  - † You can adjust Zoom +/- in 5% increments from 100% to 250%.
  - † You can also use this function by using the **MENU** button.
  - † Press the **EXIT** button to exit the menu screen.

#### Adjusting the Position

1. Press the **ZOOM** button on the remote control.
2. Press the  $\wedge, \vee$  button to select **Position** item.

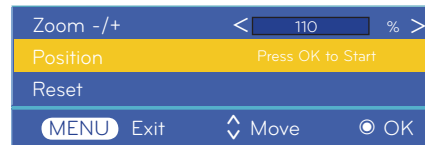

3. Press the **OK** button. When the window below appears at the bottom right corner of the screen, press the  $\wedge, \vee, <, >$  to adjust the position. When the arrow turns black, maximum adjustment has been reached and no further adjustment can be made.

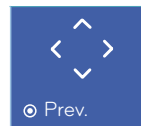

- † Position is activated only when Zoom +/- is set to more than 105%.
- † You can also use this function by using the **MENU** button.
- † Press the **EXIT** button to exit the menu screen.

### To make the power of the projector turn on automatically when power is in

1. Press the **MENU** button and then use  $<, >$  button to select the  menu.
2. Press the  $\wedge, \vee$  buttons to move to **Auto Power** and press the **OK** button.
3. Press the  $\wedge, \vee$  buttons to move to **On** and press the **OK** button.
  - **On** : Connecting power cord to the projector turns on the projector.
  - **Off** : Connecting power cord to the projector makes the projector in standby state.
  - Press the **MENU** button twice or the **EXIT** button to exit the menu screen.

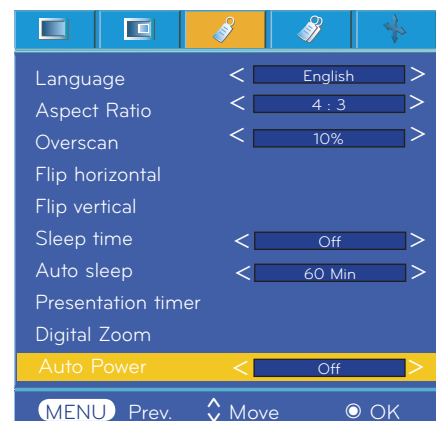

To use keystone function

1. Press the **KEYSTONE** button on the remote control.
2. Press the <, > button to select a item.

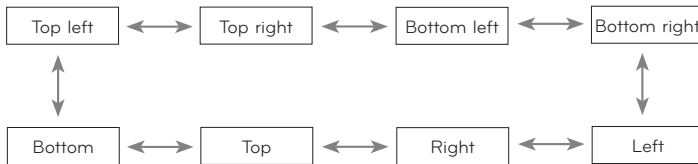

3. Press the ^, v button to select the item (H or V) you want, and press the <, > button to adjust it.

- | You can adjust each item from 0 to 100.
- | The default value may change depending on input mode.
- | You can also use this function by using the **MENU** button.
- | Press the **MENU** button to exit the menu screen.

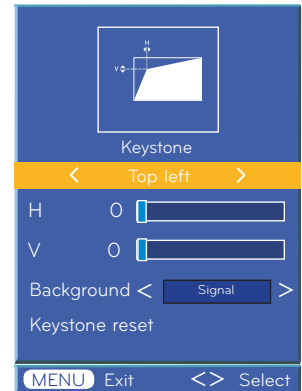

To select a background image

1. Press the **KEYSTONE** button on the remote control.
2. Please select a **Background** image by ^, v button.
3. Please select desiring item by <, > button.

| If there 's no input signal,it is possible to adjust keystone by using the adjusting pattern.



To initialize keystone

1. Press the **KEYSTONE** button on the remote control.
2. Please select keystone initialization by ^, v button.
3. Press the **OK** button. Keystone adjusting figure returns to the factory price.

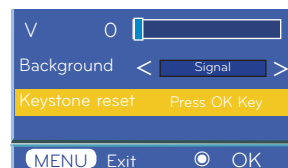

Using Blank Function

\*This function may be effective if you need to get the attention of the audience during presentations, meetings or briefings.

1. Press the **BLANK** button.
  - | The screen turns off to a background color.
  - | You can choose the background color. (Refer to 'Selecting blank image color')
2. Press any button to cancel the blank function.
  - | To temporarily turn off the lamp, press BLANK on the remote control. Do not block the projection lens with any objects when the projector is under operation as this could cause the objects to become heated and deformed or even cause a fire.

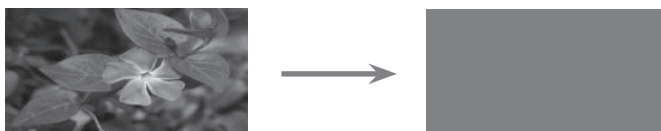

### Selecting Blank image

1. Press the **MENU** button and then use <, > button to select the  menu.
2. Press the ^, v button to select **Blank image** item.
3. Press the <, > button to select the color you want to use.
  - Background image will be altered to the selected Blank image function.
  - You can choose blue, black, green, or captured image for the Blank image.
  - If you have a captured image, you can use it as a blank image instead of logo image. And you only have one last captured image.
  - When you select the Captured image, displays a logo, if you don't have a captured image.
  - Press the **MENU** button twice or the **EXIT** button to exit the menu screen.

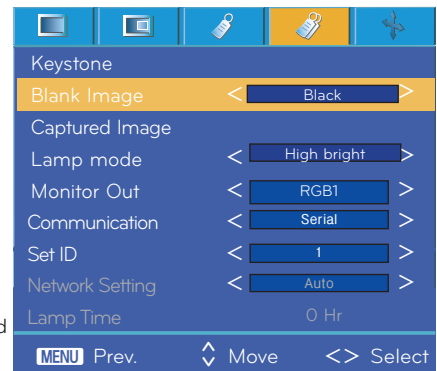

### Captured Image Function

1. Press the **MENU** button and then use <, > button to select the  menu.
2. Press the ^, v button to select **Captured Image** item.
3. Press the **OK** button to capture actual screen image.

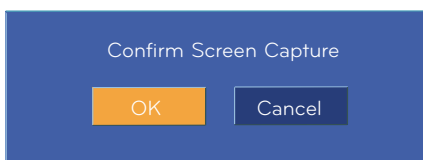

4. Press the **OK** button again to save Screen capture image.
  - You can use the captured image as a Blank image.
  - You can not use the remote control when this function is in use.
  - If you want see your captured image, select Captured image in the Blank image function.
  - Press the **MENU** button twice or the **EXIT** button to exit the menu screen.

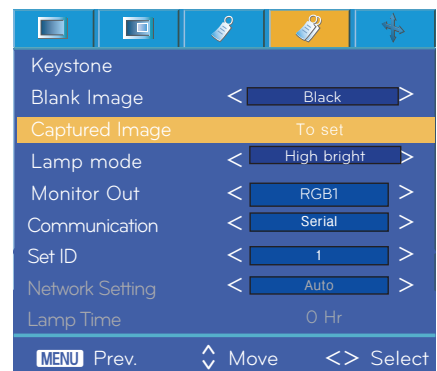

### Lamp mode Function

1. Press the **LAMP** button of remote control.
2. Press the <, > button to adjust the screen condition as you want.
  - Each press of the <, > button changes the screen as shown below.



- The menu automatically disappears at specific temperature (more than 35°C).
- It is automatically changed into power saving mode at specific temperature (more than 35°C).
- You can use this function through the **MENU** button.
- To exit the menu display, press the **EXIT** button.

### Using Monitor out Function

\* You can select either of the two RGB inputs.

1. Press the **MENU** button and then use <, > button to select the  menu.
2. Press the  $\wedge, \vee$  button to select **Monitor Out** item.
3. Press the <, > button to select **RGB1, RGB2** or **Auto**.
  - Press the **MENU** button twice or the **EXIT** button to exit the menu screen.
  - Auto mode is the mode to output an image of currently seeing input among **RGB1** or **RGB2** input.

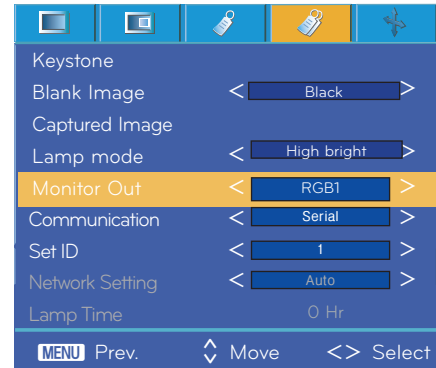

### Checking lamp time

1. Press the **MENU** button and then use <, > button to select the  menu.
2.  $\wedge, \vee$  버튼으로 원하는 통신설정을 선택하세요.
3. <, > 버튼으로 「Serial」, 「Lan」을 선택하세요.
  - \* Communication 을 「Lan」으로 설정해야 Network Setup이 활성화됩니다.
  - \* Press the **MENU** button twice or the **EXIT** button to exit the menu screen.

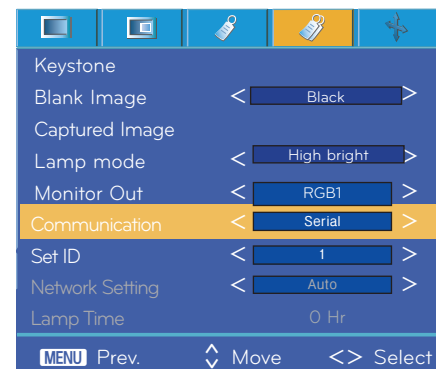

### 램프사용시간을 확인하려면

1. 메뉴 버튼을 누른 후, <, > 버튼으로  메뉴를 선택하세요.
2. 램프 사용 시간을 확인할 수 있습니다.
  - \* 램프 교체 시기가 되면 램프 경고 표시등이 적색으로 표시됩니다. (10쪽을 참고하세요.)
  - \* 램프 시간이 초과된 경우에 전원을 켜면 램프 경고 표시등은 계속 적색으로 표시됩니다
  - \* 메뉴 화면을 해제하려면 메뉴 버튼을 누르거나 취소 버튼을 누르세요.

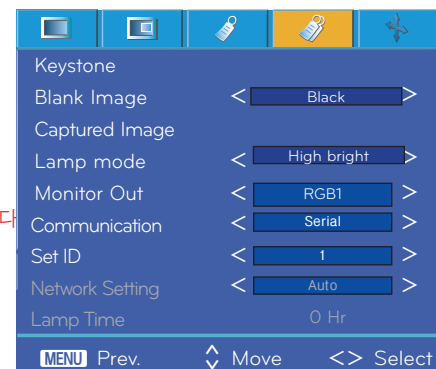

### Using Still Function

1. Press the **STILL** button of remote control.

\* You can freeze the input image.

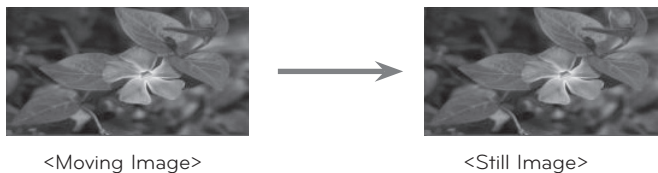

2. To exit **STILL**, press any button .

\* The STILL function will release automatically after approximately 10 minutes.

## Screen Menu Options

### Auto configure Function

- \*자동조정이란 RGB 모드에서는 프로젝터의 내부 신호와 다양한 PC 그래픽 신호가 서로 맞지 않아 수평폭의 불일치 및 화면의 떨림이 생기는 것을 자동으로 맞추어 최적의 영상상태를 찾는 기능입니다.
- \*자동조정 기능은 RGB 입력에 대해서만 동작합니다.

1. 메뉴 버튼을 누른 후 <, > 버튼으로  메뉴를 선택하세요.
2. ^, v 버튼으로 **자동조정**을 선택하세요.  
\* 영상의 위치 및 떨림이 생기는 것을 자동으로 맞추어 줍니다.
2. 자동조정을 실행하여도 다양한 PC모드 입력에 따라서 수동으로 조금 더 보정이 필요할 경우에는 메뉴에서 **미세조정, 크기조정, 수평조정, 수직조정**을 조정하여 주세요.  
경우에 따라서는 자동조정만으로는 최적의 화질을 얻지 못할 수도 있습니다.

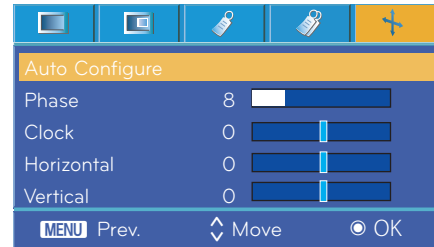

#### Note!

PC 그래픽 신호의 동영상에서 자동조정을 실행할 경우에는 최적의 영상상태를 찾지 못할 수 있으므로, 자동조정기능을 정지 영상에서 실행하여 주십시오.

### Using Phase Function

1. Press the **MENU** button and then use <, > button to select the  menu.
  2. Press the ^, v button to select **Phase** item.
  3. Press the <, > button to make desired adjustments.
- Phase adjustment range is 0 ~63.
  - The variable range can be different depends on input resolutions.
  - Press the **MENU** button twice or the **EXIT** button to exit the menu screen.

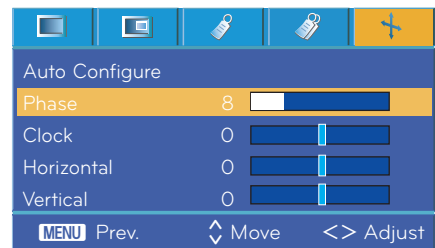

### Using Clock Function

1. Press the **MENU** button and then use <, > button to select the  menu.
  2. Press the ^, v button to select **Clock** item.
  3. Press the <, > button to make desired adjustments.
- Clock adjustment range is -20 ~ 20.
  - The variable range can be different depends on input resolutions.
  - Press the **MENU** button twice or the **EXIT** button to exit the menu screen.

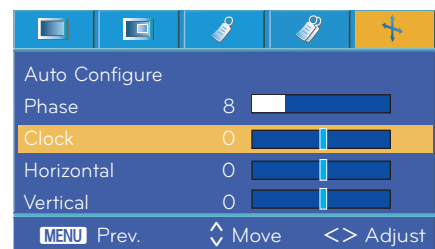

### Using Horizontal Function

1. Press the **MENU** button and then use <, > button to select the menu.
2. Press the  $\wedge, \vee$  button to select **Horizontal** item.
3. Press the <, > button to make desired adjustments.
  - Horizontal adjustment range is -50 ~ 50.
  - The variable range can be different depends on input resolutions.
  - Press the **MENU** button twice or the **EXIT** button to exit the menu screen.

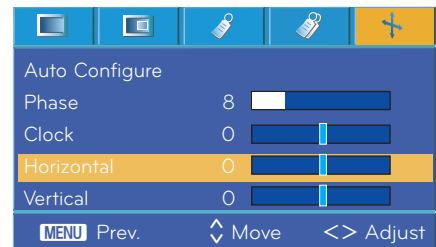

### Using Vertical Function

1. Press the **MENU** button and then use <, > button to select the menu.
2. Press the  $\wedge, \vee$  button to select **Vertical** item.
3. Press the <, > button to make desired adjustments.
  - Vertical adjustment range is -25 ~ 25.
  - The variable range can be different depends on input resolutions.
  - Press the **MENU** button twice or the **EXIT** button to exit the menu screen.

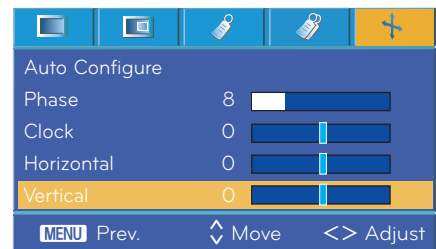

# Serial 통신 기능

\* Connect the RS-232C input jack to an external control device (such as a computer) and control the Projector's functions externally.

## SET ID

1. Press the **MENU** button and then use <, > button to select the  menu.
  2. Press the **OK** button and then use ^, v button to select **Set ID** item.
  3. Press the <, > button to select your desired number.  
Press the **OK** button to save the selected number.
- The adjustment range of **Set ID** is 1-99.
  - Only the projector with the specified ID number will operate from the remote control.
  - Press the **MENU** button twice or the **EXIT** button to exit the menu screen.

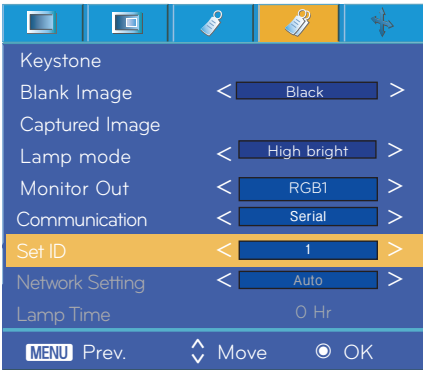

## Serial 통신으로 연결하려면

- Connect the serial port of the PC to the RS-232C jack on the projector back panel.
- RS-232C cable is not supplied with the projector.

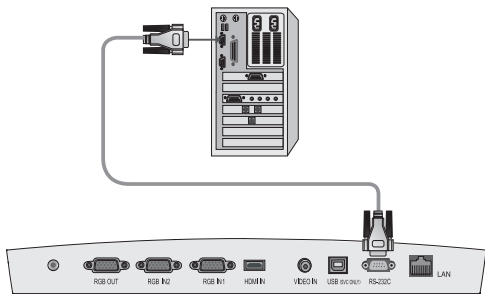

- Use the RS232C cable to control the projector externally (Refer to Fig.1).

<Fig.1, RS-232 Interface Cable>

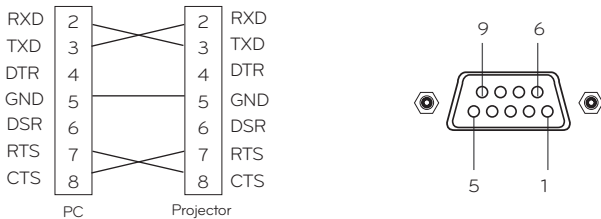

\* 1, 9 Pin No Connection



### Communication Parameter Setup

- Baud Rate : 9600 bps(UART)
- Data Length : 8 bit
- Parity : none
- Stop bit : 1 bit
- Flow Control : none
- Communication code : ASCII code



## Command Reference List

	Command 1	Command 2	Data (Hexadecimal)	실제 데이터 구조
01. Power	k	a	0 ~ 1	-
02. Aspect Ratio	k	c	1 ~ 2, 5	-
03. Blank Image	k	d	0 ~ 1	-
04. Contrast	k	g	0 ~ 64	1
05. Brightness	k	h	0 ~ 64	1
06. Color	k	i	0 ~ 64	1
07. Tint	k	j	0 ~ 64	2
08. Sharpness	k	k	0 ~ 64	1
09. OSD Select	k	l	0 ~ 1	-
10. Remote Control Lock / Key Lock	k	m	0 ~ 1	-
11. Color Temp.	k	u	0 ~ 3	-
12. Color R	j	w	0 ~ 64	1
13. Color G	j	y	0 ~ 64	1
14. Color B	j	z	0 ~ 64	1
15. Lamp Mode	n	p	0 ~ 1	-
16. Auto Configure	j	u	1	-
17. Input Select	x	b	*	-
18. Key	m	c	Key code	-

\* Refer to the detailed information for data with [\*] mark.

## Communication Protocol

\* Real data mapping 1

Decimal	Hexadecimal	Decimal	Hexadecimal	Decimal	Hexadecimal	Decimal	Hexadecimal	Decimal	Hexadecimal
0	0	21	15	41	29	61	3d	81	51
1	1	22	16	42	2a	62	3e	82	52
2	2	23	17	43	2b	63	3f	83	53
3	3	24	18	44	2c	64	40	84	54
4	4	25	19	45	2d	65	41	85	55
5	5	26	1a	46	2e	66	42	86	56
6	6	27	1b	47	2f	67	43	87	57
7	7	28	1c	48	30	68	44	88	58
8	8	29	1d	49	31	69	45	89	59
9	9	30	1e	50	32	70	46	90	5a
10	a	31	1f	51	33	71	47	91	5b
11	b	32	20	52	34	72	48	92	5c
12	c	33	21	53	35	73	49	93	5d
13	d	34	22	54	36	74	4a	94	5e
14	e	35	23	55	37	75	4b	95	5f
15	f	36	24	56	38	76	4c	96	60
16	10	37	25	57	39	77	4d	97	61
17	11	38	26	58	3a	78	4e	98	62
18	12	39	27	59	3b	79	4f	99	63
19	13	40	28	60	3c	80	50	100	64

\* Real data mapping 2

Decimal	Hexadecimal	Decimal	Hexadecimal	Decimal	Hexadecimal	Decimal	Hexadecimal	Decimal	Hexadecimal
-50	0	-29	15	-9	29	11	3d	31	51
-49	1	-28	16	-8	2a	12	3e	32	52
-48	2	-27	17	-7	2b	13	3f	33	53
-47	3	-26	18	-6	2c	14	40	34	54
-46	4	-25	19	-5	2d	15	41	35	55
-45	5	-24	1a	-4	2e	16	42	36	56
-44	6	-23	1b	-3	2f	17	43	37	57
-43	7	-22	1c	-2	30	18	44	38	58
-42	8	-21	1d	-1	31	19	45	39	59
-41	9	-20	1e	0	32	20	46	40	5a
-40	a	-19	1f	1	33	21	47	41	5b
-39	b	-18	20	2	34	22	48	42	5c
-38	c	-17	21	3	35	23	49	43	5d
-37	d	-16	22	4	36	24	4a	44	5e
-36	e	-15	23	5	37	25	4b	45	5f
-35	f	-14	24	6	38	26	4c	46	60
-34	10	-13	25	7	39	27	4d	47	61
-33	11	-12	26	8	3a	28	4e	48	62
-32	12	-11	27	9	3b	29	4f	49	63
-31	13	-10	28	10	3c	30	50	50	64

# External control device setup

## 1. Transmission

```
[Command1][Command2][Set ID][Data][Cr]
```

- \* [Command 1] : First command to control the set.(k, j, x, ASCII code, 1 Character)
- \* [Command 2] : Second command to control the set.(ASCII code, 1 Character)
- \* [Set ID] : You can adjust the set ID to choose desired projector ID number in special menu. See previous page.  
Adjustment range is 1 ~ 99. When selecting Set ID '0', every connected projector set is controlled.  
Refer to 'Real data mapping 1'.
- \* [DATA] : To transmit command data. Transmit 2 character when organized ASCII code.  
\* Transmit 'FF' data to read status of command.
- \* [Cr] : Carriage Return  
ASCII code '0x0D'
- \* [ ] : ASCII code character correspond to "Space Bar" which is in order to classify command, set ID and Data.

## 2. OK Acknowledgement

```
[Command2][Set ID][OK][Data][x]
```

- \* The Projector transmits ACK (acknowledgement) based on this format when receiving normal data. At this time, if the data is data read mode, it indicates present status data. If the data is data write mode, it returns the data of the PC computer.

## 3. Error Acknowledgement

```
[Command2][Set ID][NG][Data][x]
```

- \* The Projector transmits ACK (acknowledgement) based on this format when receiving abnormal data from non-viable functions or communication errors.

Data : [1] : illegal code(This command is not supported.)  
 [2] : not support function(This function doesn't work.)  
 [3] : wait and retry(Try again a few minute later.)

### 01. Power (Command:ka)

< To control Power On/Off of the Projector.

#### Transmission

```
[k][a][Set ID][Data][Cr]
```

Data 0 : Power Off  
1 : Power On

#### Ack

```
[a][Set ID][OK][Data][x]
```

Data 0 : Power Off  
1 : Power On

< To show Power On/Off status.

#### Transmission

```
[k][a][Set ID][FF][Cr]
```

#### Ack

```
[a][Set ID][OK][Data][x]
```

Data 0 : Power Off  
1 : Power On

\* In like manner, if other functions transmit '0xFF' data based on this format, Acknowledgement data feed back presents status about each function.

### 02. Aspect Ratio (Command:kc)

< To adjust the screen format.

#### Transmission

```
[k][c][Set ID][Data][Cr]
```

Data 1 : 4:3  
2 : 16:9  
5 : 15:10

#### Ack

```
[c][Set ID][OK][Data][x]
```

Data 1 : 4:3  
2 : 16:9  
5 : 15:10

### 03. Screen Mute (Command:kd)

< To select screen mute on/off.

#### Transmission

```
[k][d][Set ID][Data][Cr]
```

Data 0 : Screen Mute Off (Picture On)  
1 : Screen Mute On (Picture Off)

#### Ack

```
[d][Set ID][OK][Data][x]
```

Data 0 : Screen Mute Off (Picture On)  
1 : Screen Mute On (Picture Off)

**04. Contrast (Command:kg)**

< To adjust screen contrast.

**Transmission**

[k] [g] [ ] [Set ID] [ ] [Data] [Cr]

Data Min : 0 ~ Max : 64

\* Refer to 'Real data mapping 1!'

**Ack**

[g] [ ] [Set ID] [ ] [OK] [Data] [x]

Data Min : 0 ~ Max : 64

**05. Brightness (Command:kh)**

< To adjust screen brightness.

**Transmission**

[k] [h] [ ] [Set ID] [ ] [Data] [Cr]

Data Min : 0 ~ Max : 64

\* Refer to 'Real data mapping 1!'

**Ack**

[h] [ ] [Set ID] [ ] [OK] [Data] [x]

Data Min : 0 ~ Max : 64

**06. Color (Command:ki)**

< To adjust the screen color. (Video/Component)

**Transmission**

[k] [i] [ ] [Set ID] [ ] [Data] [Cr]

Data Min : 0 ~ Max : 64

\* Refer to 'Real data mapping 1!'

**Ack**

[i] [ ] [Set ID] [ ] [OK] [Data] [x]

Data Min : 0 ~ Max : 64

**07. Tint (Command:kj)**

< To adjust the screen tint.(Video/Component 60Hz or NTSC signal)

**Transmission**

[k] [j] [ ] [Set ID] [ ] [Data] [Cr]

Data Red : 0 ~ Green : 64

\* Refer to 'Real data mapping2!'

**Ack**

[j] [ ] [Set ID] [ ] [OK] [Data] [x]

Data Red : 0 ~ Green : 64

**08. Sharpness (Command:kk)**

< To adjust the screen sharpness.(Video/Component)

**Transmission**

[k] [k] [ ] [Set ID] [ ] [Data] [Cr]

Data Min : 0 ~ Max : 64

\* Refer to 'Real data mapping 1!'

**Ack**

[k] [ ] [Set ID] [ ] [OK] [Data] [x]

Data Min : 0 ~ Max : 64

**09. OSD Select (Command:kl)**

< To select OSD On/Off.

**Transmission**

[k] [l] [ ] [Set ID] [ ] [Data] [Cr]

Data 0 : OSD Select Mode Off

1 : OSD Select Mode On

**Ack**

[l] [ ] [Set ID] [ ] [OK] [Data] [x]

Data 0 : OSD Select Mode Off

1 : OSD Select Mode On

**10. Remote Control Lock/Key Lock (Command:km)**

< To lock the front panel controls on the projector and remote control.

**Transmission**

[k] [m] [ ] [Set ID] [ ] [Data] [Cr]

Data 0 : Lock Off

1 : Lock On

**Ack**

[m] [ ] [Set ID] [ ] [OK] [Data] [x]

Data 0 : Lock Off

1 : Lock On

\* If you're not using the remote control, use this mode.  
When main power is On/Off, external control lock is released.

**11. Color Temperature (Command:ku)**

< Adjust the color temperature. 단, 영상모드가 Bright 또는 Golf로 설정된 경우에는 색온도를 조정할 수 없습니다.

**Transmission**

[k] [u] [ ] [Set ID] [ ] [Data] [Cr]

Data 0 : Normal 1 : Cool 2:Warm 4 : Natural

**Ack**

[u] [ ] [Set ID] [ ] [OK] [Data] [x]

Data 0 : Normal 1 : Cool 2:Warm 4 : Natural

**12. Red ADC gain Adjustment (Color R) (Command:jw)**

< Adjust the Red gain of ADC part.(RGB)

**Transmission**

[j] [w] [ ] [Set ID] [ ] [Data] [Cr]

Data Min : 0 ~ Max : 64

\* Refer to 'Real data mapping 1!'

**Ack**

[w] [ ] [Set ID] [ ] [OK] [Data] [x]

Data Min : 0 ~ Max : 64

**13. Green ADC gain Adjustment (Color G)  
(Command: jy)**

< Adjust the Green gain of ADC part.(RGB)

Transmission

[ j ] [ y ] [ ] [Set ID] [ ] [Data] [Cr]

Data Min : 0 ~ Max : 64  
\* Refer to 'Real data mapping 1'.

Ack

[ y ] [ ] [Set ID] [ ] [OK] [Data] [x]

Data Min : 0 ~ Max : 64

**14. Blue ADC gain Adjustment (Color B)  
(Command: jz)**

< Adjust the Blue gain of ADC part.(RGB)

Transmission

[ j ] [ z ] [ ] [Set ID] [ ] [Data] [Cr]

Data Min : 0 ~ Max : 64  
\* Refer to 'Real data mapping 1'.

Ack

[ z ] [ ] [Set ID] [ ] [OK] [Data] [x]

Data Min : 0 ~ Max : 64

**15. Lamp Mode (Command: np)**

< To reduce the power consumption of the projector.

Transmission

[ n ] [ p ] [ ] [Set ID] [ ] [Data] [Cr]

Data 0 : Low Power Off  
1 : Low Power On

Ack

[ p ] [ ] [Set ID] [ ] [OK] [Data] [x]

Data 0 : Low Power Off  
1 : Low Power On

**16. Auto Configure (Command: ju)**

< To adjust picture position and minimize image shaking automatically. It works only in RGB mode.

Transmission

[ j ] [ u ] [ ] [Set ID] [ ] [Data] [Cr]

Data 1 : To set

Ack

[ u ] [ ] [Set ID] [ ] [OK] [Data] [x]

Data 1 : To set

**17. Input Select (Command: xb)**

< To select input source for the Set.

Transmission

[ x ] [ b ] [ ] [Set ID] [ ] [Data] [Cr]

Data 20 : Video  
60 : RGB1 61 : RGB2 90 : HDMI

Ack

[ b ] [ ] [Set ID] [ ] [OK] [Data] [x]

Data 20 : Video  
60 : RGB1 61 : RGB2 90 : HDMI

**18. Key (Command: mc)**

< To send Key code of IR remote control.

Transmission

[ m ] [ c ] [ ] [Set ID] [ ] [Data] [Cr]

Data Key code

Ack

[ c ] [ ] [Set ID] [ ] [OK] [Data] [x]

Key code

^	40
v	41
<	03
>	02
Power	AD
Input	EF
Menu	43
Exit	5B
● OK	44
Still	BC
Ratio	79
Blank	84
Timer	26
White Peaking	69
Keystone	A4
Gamma	6E
Picture mode	4D
⊞	4F
●	4E
Digital Zoom	5C
Lamp Mode	68
Sleep Time	0E
Auto Configure	92
FILP V.	96
FILP H.	97

## 네트워크 설정 기능

### 네트워크 설정 기능을 사용하려면

\* 사용자가 LAN을 이용하여 프로젝터를 원격 제어 할 수 있는 기능입니다.

< 연결방법 >

프로젝터의 LAN 단자와 컴퓨터의 LAN 단자를 연결하세요.

#### ① 자동설정

< 사용 방법 >

1. 메뉴 버튼을 누른 후 <, > 버튼으로  메뉴를 선택하세요.
2. ^, v 버튼으로 **통신설정**을 선택하세요.
3. <, > 버튼으로 「LAN」을 선택하세요.
4. ^, v 버튼으로 **네트워크 설정**을 선택하세요.
5. <, > 버튼으로 「자동설정」을 선택하세요.

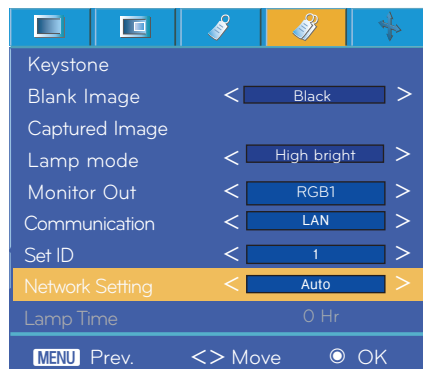

IP setting in progress, Please wait...

```
IP Address  1 9 2 . 1 6 8 . 0 0 0 . 0 0 5
Subnet Mask 2 5 5 . 2 5 5 . 2 5 5 . 0 0 0
Gateway    1 9 2 . 1 6 8 . 0 0 0 . 0 0 1
IP setting is succeeded.
```

MENU Prev.

- 자동설정으로 네트워크 설정이 완료되었습니다.

② 수동설정

< 사용 방법 >

1. 메뉴 버튼을 누른 후 <, > 버튼으로  메뉴를 선택하세요.
2. ^, v 버튼으로 **통신설정**을 선택하세요.
3. <, > 버튼으로 「LAN」을 선택하세요.
4. ^, v 버튼으로 **네트워크 설정**을 선택하세요.
5. <, > 버튼으로 「수동설정」을 선택하세요.
6. PC의 IP를 설정하고, 프로젝터의 IP도 PC와 같은 대역에 속하도록 설정합니다.  
(예: PC IP - 192.168.0.10, 프로젝터 IP - 192.168.0.5)  
^, v 버튼으로 숫자를 조정하고, <, > 버튼으로 다음 칸으로 이동합니다.

\* 이전으로 돌아가려면 메뉴 버튼을 누르세요.

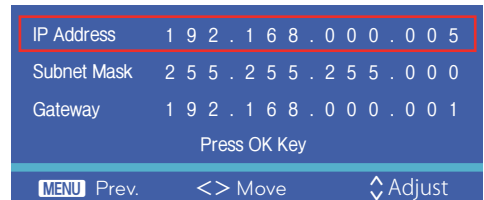
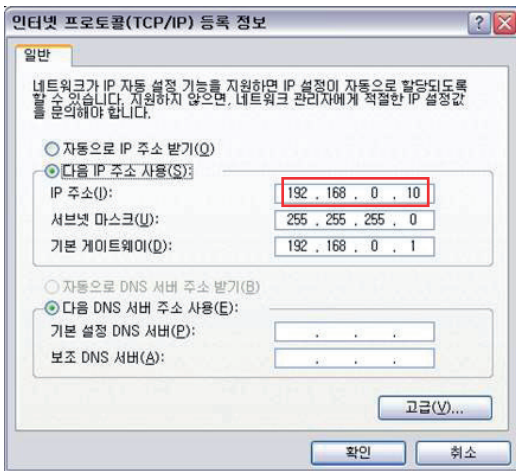
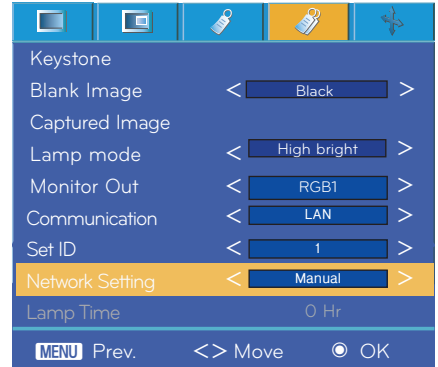

7. IP 설정 후 **확인** 버튼을 누르세요.  
IP 주소가 저장됩니다.

8. 수동설정으로 **네트워크 설정**이 완료됩니다.

IP setting in progress, Please wait...

IP setting is succeeded.

## Supported Monitor Display

\* The following table lists the display formats supported by the projector.

Sources	Format	Vertical Freq.(Hz)	Horizontal Freq.(kHz)
EGA	640X350	70.09Hz	31.468kHz
	640X350	85.08Hz	37.861kHz
PC98	640X400	85.08Hz	37.861kHz
DOS	720X400	70.08Hz	31.469kHz
	720X400	85.03Hz	37.927kHz
VGA	640X480	59.94Hz	31.469kHz
	640X480	72.80Hz	37.861kHz
	640X480	75.00Hz	37.500kHz
	640X480	85.00Hz	43.269kHz
SVGA	800X600	56.25Hz	35.156kHz
	800X600	60.31Hz	37.879kHz
	800X600	72.18Hz	48.077kHz
	800X600	75.00Hz	46.875kHz
	800X600	85.06Hz	53.674kHz
XGA	1024X768	60.00Hz	48.363kHz
	1024X768	70.06Hz	56.476kHz
	1024X768	75.02Hz	60.023kHz
	1024X768	84.99Hz	68.677kHz
SXGA	1152X864	60.05Hz	54.348kHz
	1152X864	70.01Hz	63.995kHz
	1152X864	75.00Hz	67.500kHz
	1280X960	60.00Hz	60.000kHz
	1280X960	85.00Hz	85.940kHz
	1280X1024	60.02Hz	63.981kHz
1280X1024	75.025Hz	79.976kHz	
SXGA+	1400X1050	60.00Hz	65.317kHz

\* If the projector does not support the input signal, "Out of Range" message appears on the screen.

\* The projector supports DDC1/2B type as Plug & Play function. (Auto recognition of PC monitor)

\* The Synchronization input form for horizontal and vertical frequencies are Separate.

\* According to PC, the optimum vertical frequency may not be displayed up to the optimum frequency of set in 'Registration information (Display registration information)'. (ex, The optimum vertical frequency may be displayed up to 85Hz or under in the resolution of 640X480 or 800X600.)

### <DVD/DTV Input>

Signal	Component-*1	HDMI(DTV)-*2
59.94 / 60Hz	480i	○
	480p	○
	720p	○
	1080i	○
50Hz	576i	○
	576p	○
	720p	○
	1080i	○
24/25/30Hz	1080p	○

\* Cable type  
 1- RCA to D-Sub Adapter  
 2- HDMI to HDMI Cable

# Replacing the Lamp

## Lamp Replacement

The change interval of lamp may depend on the use environment of Projector. You can see the used lamp time in the CHECKING LAMP TIME section of the Menu (page.29). You must replace the lamp when:

- | The projected image gets darker or starts to deteriorate.
- | The lamp indicator is red.
- | The message "Replace the lamp" appears on the screen when turning the projector on.

<Front panel of the Projector>

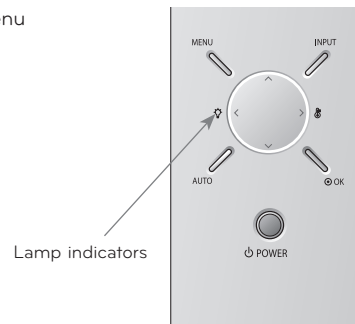

## Be careful when replacing lamp

- Press the POWER button on the control panel or remote control to turn off power.
- If the operation indicator LED is orange and blinking, do not disconnect the main supply until the operation indicator LED is lit up constantly (orange).
- Allow the lamp to cool for 1 hour before replacing it.
- Replace only with the same type lamp from an LG Electronics Service Center. Using another manufacturers lamp may cause damage to the Projector and lamp.
- Pull out the lamp only when replacing the lamp.
- Keep the lamp unit out of reach of children. Keep the Lamp away from heat sources such as radiators, stoves etc.
- To reduce the risk of fire do not expose the lamp to liquids or foreign materials.
- Do not place the lamp near any heat source.
- Make sure the new lamp is securely tightened with screws. If not, the image may be dark or there could be an increased risk of fire.
- Never touch the lamp unit glass otherwise image quality may be compromised or lamp life maybe reduced.

## To obtain a replacement Lamp unit

Lamp model number is on page 42. Check the lamp model and then purchase it from an LG Electronics Service Center. Using another manufacturers lamp may cause damage to the projector.

## Lamp unit disposal

Dispose of the used lamp by returning it to the LG Electronics Service Center.



## 램프 교체 방법

### 램프 덮개를 분해하여 램프를 교체하려면

- 1 프로젝터의 전원을 끄고 전원 케이블을 콘센트에서 뽑습니다. 설치된 프로젝터를 분리하여 테이블 위나 바닥이 평평한 곳에 놓으세요.  
(램프 표면은 뜨거우므로 1시간 이상 경과 후 램프를 교체하세요.)

- 2 드라이버 또는 이와 유사한 물체를 이용하여 측면 부위의 스크류를 풀어주세요. 스크류를 뺀 후, 램프 덮개를 화살표 방향처럼 비스듬히 들어올려 주세요. 이 때, 수직방향으로 당기지 마세요.

만약 램프 덮개가 들러 올라가지 않으면 "A" 부를 눌러주세요.

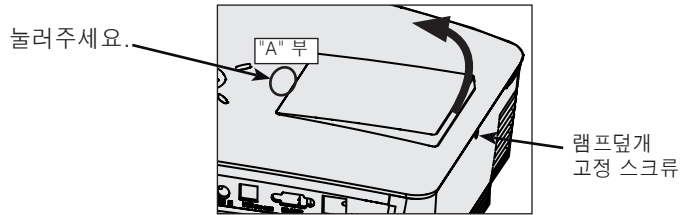

- 3 램프 덮개를 열고, 드라이버 또는 이와 유사한 물체를 이용하여 램프를 고정시키는 두 개의 나사를 풀어주세요.

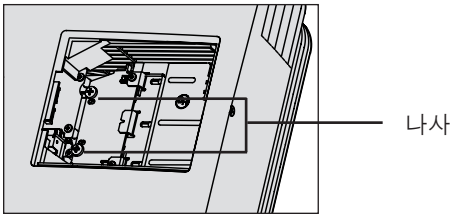

- 4 고정된 램프 손잡이를 걸림턱으로부터 빼내세요.

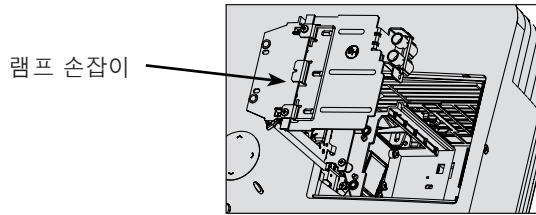

- 5 램프 손잡이를 잡고 천천히 당기면 램프 케이스가 빠집니다.

- 6 새 램프 케이스를 조심스럽게 정위치로 넣습니다. 정확하게 끼워졌는지 확인하세요.

- 7 3번에서 풀어 놓은 나사들을 고정시키세요. (램프가 견고하게 고정되었는지 확인하세요)

- 8 램프 덮개를 닫고 2번에서 풀었던 볼트로 고정시킵니다. (램프 덮개가 열려있는 상태에서 전원을 켜면 램프 경고 표시등이 녹색으로 점멸되고 프로젝터가 켜지지 않습니다.)

#### 잠깐!

램프 교체시 반드시 동일한 기종의 램프로 교체하세요.  
램프 교체 후 램프 덮개를 정확히 닫지 않으면 프로젝터가 켜지지 않을 수 있습니다. 이 경우 램프가 정상적으로 고정되었는지 확인 후 서비스 센터로 연락 바랍니다.

### 램프 덮개를 다시 조립하려면

- 1 램프 덮개가 지지선에 끝까지 닿도록 밀착시키세요. (기울기를 30° 정도 유지하세요.)

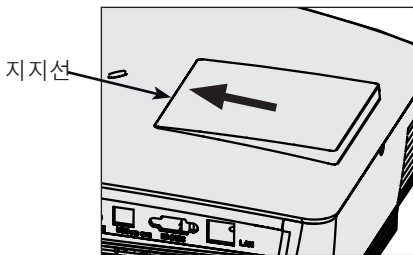

- 2 수직으로 힘을 가하지 말고 대각선 방향으로 힘을 주어 밀어 넣듯이 삽입하세요.

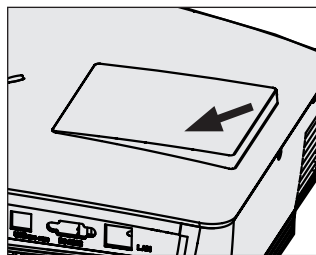

#### 잠깐!

램프 탈부착시 하기 끝단부위에 무리한 힘이 가하지 않도록 하세요.

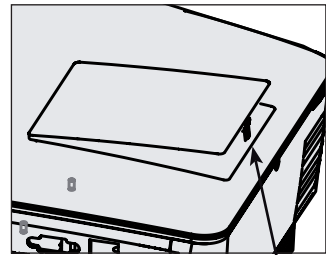

- 3 측면부위 스크류 체결시 무리한 힘으로 조여지지 않도록 하세요. 고정시 토오크(torque)는 4~5kgf.cm의 힘으로 고정하세요.

### Regarding the projector lamp control

#### ⚠ WARNING

- | Don't turn off the projector at least in 5 minutes after activating it.
  - The frequent On/Off changes may cause the lamp function to deteriorate.
- | Don't pull out the power cord while activating the projector and the cooling fan.
  - It may cause the lamp life-span to shorten and get damaged.
- | The life-span of projector may considerably depend on the use environment and treatment conditions.
- | The projector uses the high pressure mercury lamp so that the serious caution is essential. The shock or abuse while using may cause lamp to blow off with explosion.
- | When you continue to use the projector after an interval of lamp replacement, the lamp may be blown off with explosion.
- | The following treatment should be done, in case of lamp blow-off.
  - Pull off the power cord immediately.
  - Let some fresh air in immediately (Ventilation).
  - Check the product condition at the nearer service center and replace it with new lamp, if necessary.
  - Don't try to disassemble the product without the authorized technician.

## How to fix the lens cap to the projector

### How to fix the lens cap

- 1** Prepare the lens cap and the strap supplied as accessories.

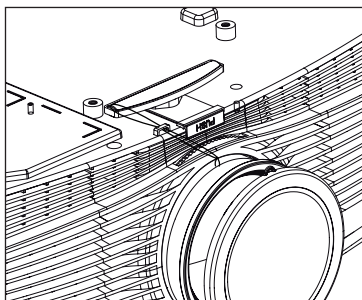

Fix the strap at the hole of the projector into the hole of the lens cap, and then pass the lens cap through the strap lasso.

**3**

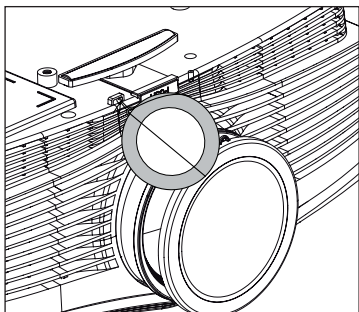

- 2** Insert the non-knot end of the strap into the hole at the bottom of the lens section of the projector.

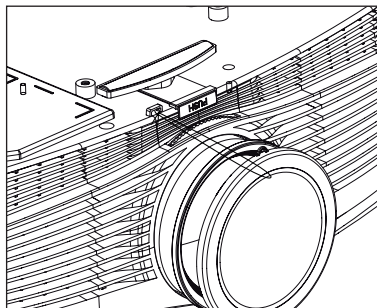

- 4** They are completely assembled as shown at the below figure.

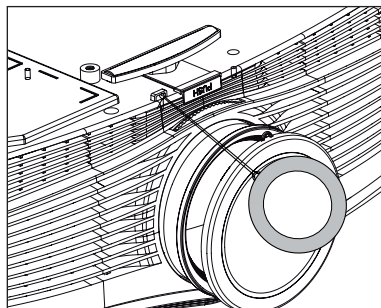

## Specifications

MODEL	BX503 (BX503-JD) / BX403B (BX403B-JD)
Power	AC 100 - 240V~ 50/60Hz, 4.3A
Resolution	1024(Horizontal) x 768(Vertical)pixel
Horizontal / Vertical Ratio	4:3(horizontal:vertical)
DLP panel size(mm)	17.8
Screen size (Projection distance)	Wide : 1.0 ~ 7.5m Tele : 1.2 ~ 8.7m
Projection off-set ratio	100%
Remote control distance	12m
Zoom ratio	1:1.2
Video compatibility	NTSC/PAL/SECAM/NTSC4.43/PAL-M/PAL-N
Height(mm)	148.5 (with foot), 135.7(without foot)
Breadth(mm)	403.3
Length(mm)	293.1
Weight(kg)	5.8

### Operating Condition

#### Temperature

In operation : 32~104°F(0°C~40°C)  
In storage and transit : -4~140°F(-20°C~60°C)

#### Humidity

In operation : 0 ~ 80% relative humidity by dry hygrometer  
Not in operation : 0 ~ 85% relative humidity by dry hygrometer

### Projector Lamp

#### Lamp model

AJ-LBX50

#### Lamp power consumption

330W



The model and serial number of the projector is located on the back or one side of the projector. Record it below should you ever need service.

MODEL \_\_\_\_\_

SERIAL \_\_\_\_\_