

XV-Z3000

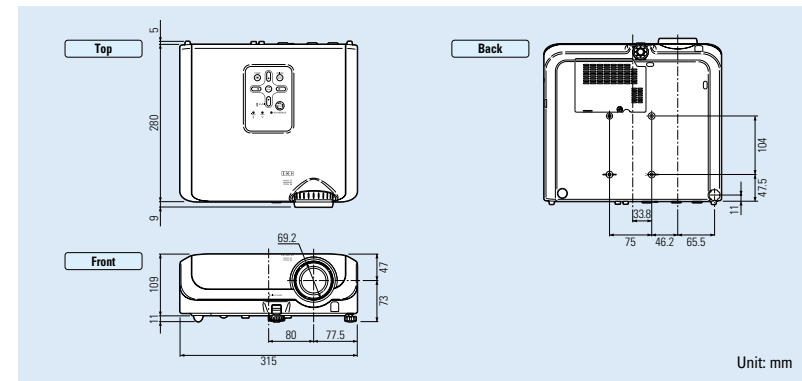

Dimensions







SHARP

XV-Z3000
High-Definition DLP™ Home Theatre Projector

High-Definition DLP™ Projector Provides Amazingly High 6500:1 Contrast Ratio and Expands Home Theatre Entertainment!

Optional Accessories

Lamp	Adaptor	Cable	Ceiling Mounts
 AN-100LP	 AN-A1RS DIN-D-sub RS-232C adaptor (15 cm)	 AN-C3CP2 3-RCA to 15-pin D-sub cable (3 m)	 AN-TK201 For high ceiling installation AN-60TK Installation adaptor

Note: Some of the optional accessories may not be available depending on the region. Please check with your nearest Sharp Authorized Projector Dealer or Service Center.

Specifications

Model	XV-Z3000
DMD™ chip	0.65" (1,280 x 768 dots) Digital Micromirror Device™ (DMD™) x 1 by Texas Instruments
Number of pixels	983,040 pixels (1,280 x 768)
Resolution	720 TV lines (DTV 720P input), 520 TV lines (video input)
HDTV compatibility*1	1080i (in intelligent compression), 720P, 576P, 576i, 480P, 480i
Computer RGB input signals	XGA, SVGA, VGA, Mac 19"/16"/13"
Video colour systems	NTSC/NTSC4.43/PAL/PAL(60Hz)/PAL-M/PAL-N/SECAM
Lens	1:1.15 manual zoom and focus
Projection size	40" – 300"
Projection distance	3.0 – 3.45 m for 16:9 wide 100" screen
Luminance	1,200 ANSI Lumen (in High-Brightness Mode)
Contrast ratio	6,500:1 (in High Contrast Mode)
Input terminals	3RCA (component) x 2, RCA video x 1, S-video x 1, HD-15 (RGB/component) x 1
RGB terminal	HDMI (digital video component & RGB) x 1
Power source	AC 100-240 V, 50/60 Hz (multi-voltage)
Power consumption	355 W (standby 6.6 W) with AC 100 V
Fan noise	33 dB (Standard Mode), 30 dB (Low Power Mode)
Projection lamp	275 W (SHP)
Lamp life	3,000 hours (Low Power Mode)
Dimensions (W x H x D)	315 x 120 x 294 mm (including adjuster legs and lens), 315 x 109 x 280 mm (main body only)
Weight	4.0 kg (including adjuster legs and lens)
Supplied accessories	Lens cap, power cord, phosphorescent remote control

Design and specifications are current as of March 2006, but are subject to change without notice.
*1 High Definition Television (HDTV) Monitor. Defined by CEA (Consumer Electronics Association, USA) to designate a 16:9 aspect ratio monitor or display with active vertical scanning lines of 720 progressive (720p) and higher.
* DLP™, the DLP™ logo, the DLP™ medallion and BrilliantColor™ are trademarks of Texas Instruments.



SHARP
SHARP CORPORATION OSAKA, JAPAN
URL <http://www.sharp-world.com/>



HD
ready

SHARP VISION

6500:1 Superb Contrast Ratio with High-Brightness, High-Quality Picture Reproduction Plus DLP™ High-Reliability Performance



Cutting-Edge DLP™ Technology Provides High-Quality Picture

6500:1 High-Contrast Images

Employing a thoroughly developed optical engine with the reflective device of DMD™ that can prevent light from coming through by controlling mirror angles, the XV-Z3000 enhances fine, detailed differences between darkest and lightest colours and provides superior black level reproduction. Real blacks and clearly reproduced and subtle colours provide impressively beautiful pictures.



Native 720p High Definition Capability

The XV-Z3000 provides high-quality images from DVD, HDTV and DTV (480P, 720P, 1080i, with 4:3 and 16:9 aspect ratios) by receiving RGB signals and component signals (Y, PB, PR).



DLP™ Digital Image

The XV-Z3000 utilizes the DLP™ chip from Texas Instruments with a resolution of 1,280 x 768. Using DMD, each pixel is individually composed of one of over a half a million micromirrors to produce a high resolution, and the micromirrors lie at an instance of merely one micron, providing a seamless finely detailed picture. Also, high-speed on/off switching delivers smooth moving scenes.

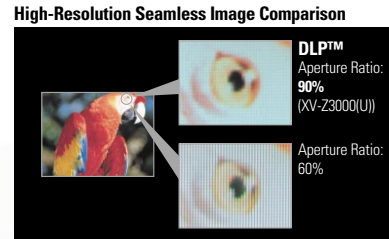

Sealed Optics

The optical mechanism of DLP™ system projectors is sealed in its structure, preventing dust, dirt and smoke from entering core parts of the optics. The system also needs no filter and less maintenance, resulting in lower cost of ownership and longer use.

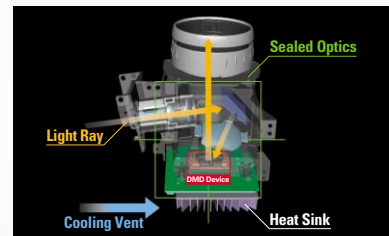

Long-Life High-Performance DLP™ Picture

With DLP™ technology minimally absorbing high-output light, the projectors maintain uniform colour reproduction capability for a long period of time. Also, DMD™ silicon chip formation with finely structured mirrors provides stable performance and delivers high-quality pictures for longer periods. The DMD™ chip in the XV-Z3000 contributes to a long lifespan. In addition, because there is no burn-in or remaining afterimage, the projectors are ideal for still picture projection such as for guidance board applications and projecting CAD images.

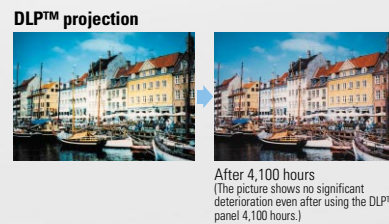

* By RIT/Munsell Colour Science Laboratory Test

5x Speed Colour Wheel

The colour wheel capable of 5x speed (by rotating the colour wheel with 6-part colour at 2.5x speed) renders colour breaking imperceptible to the human eye.

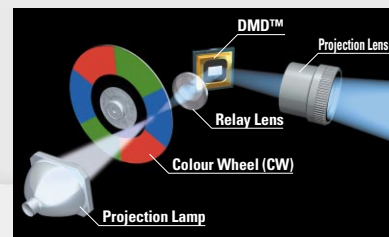

1200 ANSI Lumen in High Brightness Mode

Incorporating Sharp optoelectronics technology, the XV-Z3000 provides 1200 ANSI lumen brightness in high brightness mode to enjoy large-screen pictures.

High-Quality Digital Connection

HDMI Terminal

Use of HDMI terminals, the interface for digital content, delivers all-digital projection from input straight through to the projected picture without picture loss, which usually occurs from A/D and D/A conversion or from digital cinemas using DLP™. As well, this helps to build a Home Theatre PC environment using a computer with a DVI output terminal for DVD entertainment.



Home Theatre Performance and Convenience

Short Throw Lens (Optical 1.15x Zoom Lens)

The newly developed Short Throw Lens achieves 60-inch large screen projection even from the short distance of 1.8 m*. In addition, the projector can be mounted more flexibly with the 1.15x zoom lens.

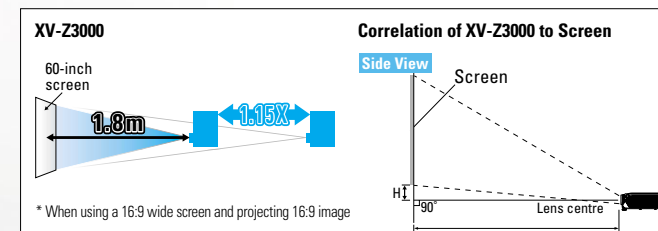

Screen Size and Projection Distance

Diag. (inches)	Screen size		Projection distance (L)		Distance from the lens centre to the bottom of the image (H)
	Width (cm)	Height (cm)	Minimum	Maximum	
200	443	249	6.0 m	7.0 m	-36 cm
100	221	125	3.0 m	3.5 m	-18 cm
60	133	75	1.8 m	2.1 m	-11 cm
40	89	50	1.2 m	1.4 m	-7 cm

NORMAL Mode (4:3)

Diag. (inches)	Screen size		Projection distance (L)		Distance from the lens centre to the bottom of the image (H)
	Width (cm)	Height (cm)	Minimum	Maximum	
200	406	305	7.4 m	8.6 m	-44 cm
100	203	152	3.7 m	4.3 m	-22 cm
60	122	91	2.2 m	2.6 m	-13 cm
40	81	61	1.5 m	1.7 m	-9 cm

Colour Management System (C.M.S.)

Independently controls colour hue, chrome and brightness for the six RGBCMY colours (red, green, blue, cyan, magenta and yellow), enabling users to match the image quality to their preferences.

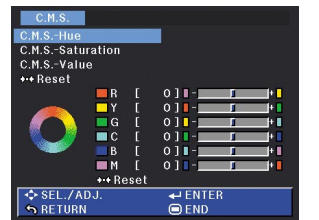

Back-lit Remote Control and Easy-to-Use Operation Buttons

The phosphorescent buttons and intuitive button layout make remote control smooth and easy even in dark rooms.



Other Outstanding Features

- BrilliantColor™ Function
- High-Powered 275 W Lamp with a long 3000-hour life
- 2D Digital Keystone Correction
- Colour Temperature Adjustment
- Gamma Correction Function
- Low Fan Noise: 30 dB (Low Power Mode)

