



ProSelecta

View :: Compare :: Select - www.ProSelecta.com

LG LCD PROJECTOR

Please read this manual carefully before operating your set.

Retain it for future reference.

Record model number and serial number of the set.

See the label attached on the bottom of the set and quote this information to your dealer when you require service.

Model number :

Serial number :

**RL-JA20
OWNER'S MANUAL**



LCD PROJECTOR

Warning

This is a class B product. In a domestic environment this product may cause radio interference, in which case the user may be required to take adequate measures.

FCC NOTICE

• A Class B digital device

This equipment has been tested and found to comply with the limits for a Class B digital device, pursuant to Part 15 of the FCC Rules. These limits are designed to provide reasonable protection against harmful interference in a residential installation. This equipment generates, uses and can radiate radio frequency energy and, if not installed and used in accordance with the instructions, may cause harmful interference to radio communications. However, there is no guarantee that interference will not occur in a particular installation. If this equipment does cause harmful interference to radio or television reception, which can be determined by turning the equipment off and on, the user is encouraged to try to correct the interference by one or more of the following measures:

- Reorient or relocate the receiving antenna.
- Increase the separation between the equipment and receiver.
- Connect the equipment into an outlet on a circuit different from that to which the receiver is connected.
- Consult the dealer or an experienced radio/TV technician for help.

- **Any changes or modifications not expressly approved by the party responsible for compliance could void the user's authority to operate the equipment.**

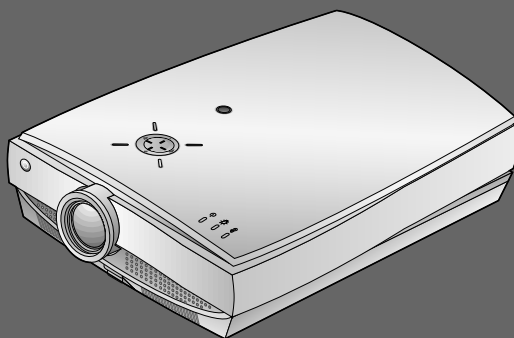

CONTENTS

INTRODUCTION

Safety Instructions	4
Names of parts	12

INSTALLATION AND COMPOSITION

Installation Instructions	18
Composition	20
Turning on the Projector	22
Turning off the Projector	23
Operating the Projector	24
Selecting source mode	25

CONNECTION

Connecting to a Desktop PC	26
Connecting to a Notebook PC	27
Connecting to a Macintosh Desktop PC	28
Connecting to a Macintosh PowerBook	31
Connecting to a wireless transmitter (option)	32
Connecting to a wireless receiver (option)	33
Connecting to a Video Source	34
Connecting to a DVD	35
Connecting to a D-TV Set-Top Box	36

BASIC FUNCTIONS

Function checking	37
Using Still function	38

SPECIAL FUNCTIONS

Selecting language	39
Checking lamp time	40
Manual Color Temperature Control	41
Using Blank function	42
Using Flip Horizontal / Vertical function	44
Twin Picture function	46

POSITIONING

Adjusting screen display	48
Using Keystone function	49
Using Zoom function	50
Using ARC function	51

VIDEO

Adjusting Video	52
-----------------------	----

TRACKING

Using Tracking function	54
-------------------------------	----

RS-232C

External control device setup	56
-------------------------------------	----

INFORMATION

Supported Monitor Display	63
Maintenance	64
Memo	65
Specifications	67

After reading this manual please keep it in a safe place for future reference.

Safety Instructions

► Please take note of the safety instructions to prevent any potential accident or misuse of the projector.

► Safety Instructions are given in two forms as detailed below.

 **WARNING** The violation of this instruction may cause serious injuries and even death.

 **NOTES** The violation of this instruction may cause light injuries or damage to the projector.

► After reading this manual, keep it in the place that the user always can contact easily.

Indoor Installation-WARNING

Do not place the Projector in direct sunlight or near heat sources such as radiators, fires and stove etc.

- This may cause a fire hazard !

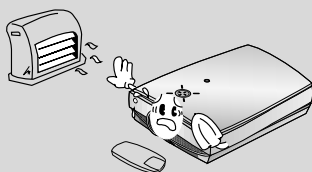

Do not place inflammable materials beside the projector

- This may cause a fire hazard !

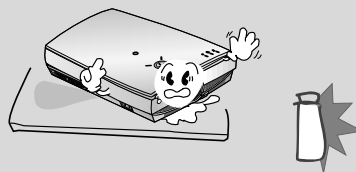

Do not allow children to hang on the installed projector.

- It may cause the projector to fall, causing injury or death.



Indoor Installation-NOTES

Disconnect from the mains and remove all connections before moving.

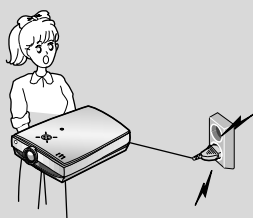

Do not place the projector close to sources of steam or oil such as a humidifier.

- This may create a fire hazard or an electric shock hazard !

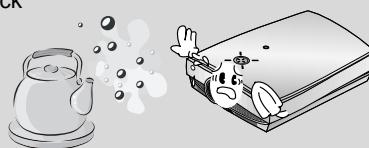

**Indoor Installation-NOTES**

Do not place the projector where it might be exposed to dust.

- This may cause a fire hazard !



When installing the projector on a table, be careful not to place it near the edge.

- This may cause the projector to fall causing serious injury to a child or adult and serious damage to the projector.
- **Only use a suitable stand.**



Only use the projector on a level and stable surface.

- It may become unstable and affect operation.



Ensure good ventilation around the projector. The distance between the projector and the wall should be more than 30cm.

- An excessive increase in its internal temperature may cause a fire hazard!

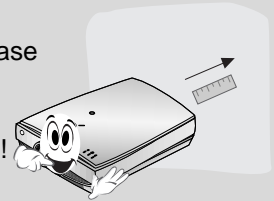

Do not block the vents (air intake/exhaust) of the projector or restrict air-flow in any way.

- This would cause the internal temperature to increase and could cause a fire hazard!

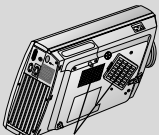

Air intake

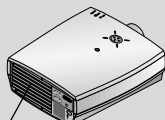

exhaust pipe

Do not place the projector directly on a carpet, rug or place where ventilation is restricted.

- This would cause its internal temperature to increase and might create a fire hazard !

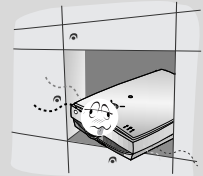
**Outdoor Installation-WARNING**

Do not use the projector in a damp place such as a bathroom where it is likely to get wet.

- This may cause a fire or an electric shock hazard !



In case of using a receiver (VCR, Digital Set Top Box), bend antenna cable between inside and outside building to prevent rain from flowing in.

- This may cause water damaged inside the projector and could give an electric shock.

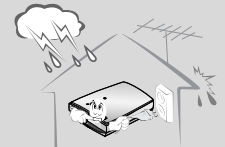

Safety Instructions



Outdoor Installation-NOTES

In case of using a receiver (VCR, Digital Set Top Box), do not place an antenna in the vicinity of power lines.

- This may cause an electric shock.

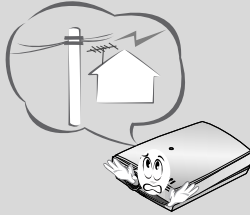

If connecting a receiver (VCR, Digital Set Top Box), contact your service centre to erect an antenna as this work should be carried out by skilled personnel.

- This may cause an electric shock.

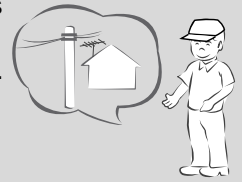

In case of using a receiver (VCR, Digital Set Top Box), there should be enough distance between an outside antenna and power lines to keep the former from touching the latter even when the antenna falls.

- This may cause an electric shock.

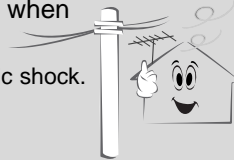

Power-WARNING

Earth wire should be connected.

- If the earth wire is not connected, there is possible a danger of electric shock caused by the current leakage.
- If grounding methods are not possible, a separate circuit breaker should be employed and installed by a qualified electrician.
- Do not connect ground to telephone wires, lightning rods or gas pipe.

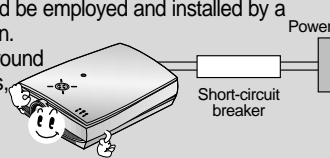

The mains plug should be inserted fully into the power outlet to avoid a fire hazard !

- This may cause a fire hazard !



Do not place heavy objects on the power cord

- This may cause a fire or an electric shock hazard !



Do not use too many plugs on the Mains multi-outlet.

- It may result in overheating of the outlet and causes a fire hazard !

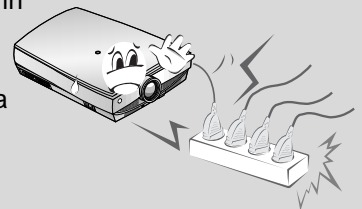

⚠ Power-NOTES

Never touch the power plug with a wet hand

- This may cause an electric shock hazard !

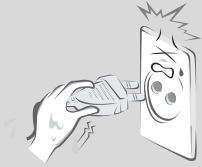

Hold the plug firmly when unplugging. If you pull the cord the cord may be damaged.

- This may cause a fire hazard !



Prevent dust collecting on the power plug pins or outlet.

- This may cause a fire hazard !

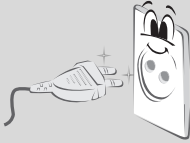

Do not plug when the power cord or the plug is damaged or the connecting part of the power outlet is loose.

- This may cause a fire or an electric shock hazard !

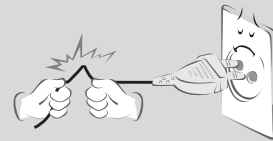

Ensure the power cord does not come into contact with sharp or hot objects such as a heater.

- This may cause a fire or an electric shock hazard !

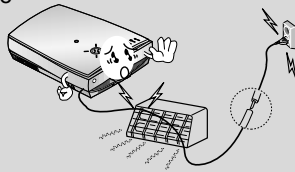

Place the projector where people will not trip or tread on the power lead.

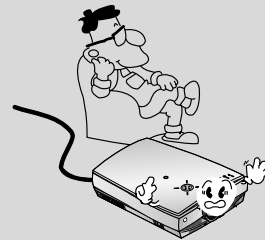

Do not turn the projector On/Off with plugging-in or unplugging the power plug to the wall outlet. (Do not use the power plug for switch.)

- It may cause mechanical failure or could give an electric shock.



Safety Instructions



Using-WARNING

Do not place anything containing liquid on top of the projector such as flowerpot, cup, cosmetics or candle.

- This may cause a fire hazard !

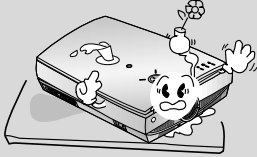

In case of impact shock or damage to the projector switch it off and unplug it from the mains outlet and contact your service center.

- This may cause a fire or an electric shock hazard !



Do not allow any objects to fall into the projector.

- This may cause an electric shock hazard !

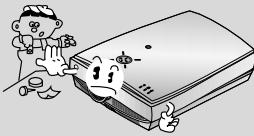

If water is spilt into the projector unplug it from the mains supply outlet immediately and consult your Service Agent.

- This may cause an electric shock hazard !

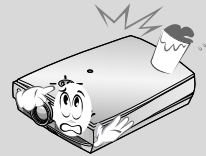

Dispose of used batteries carefully and safely.

- In the case of a battery being swallowed by a child please consult a doctor immediately.



In the event that an image does not appear on the screen please switch it off and unplug it from the mains supply and contact your Service Agent.

- This may cause a fire or an electric shock hazard !



Do not use the projector in a moving vehicle.

- This may cause an accident.

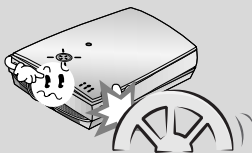

Do not remove any covers (except lens cover). High risk of Electric Shock!



⚠ Using-WARNING

Don't look directly onto the lens when the projector is in use. Eye damage may occur!

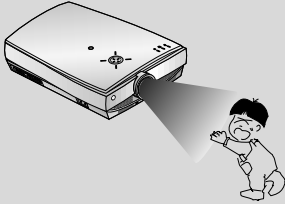

Do not touch metal parts during or soon after operation since the vents and lamp cover will remain very hot!

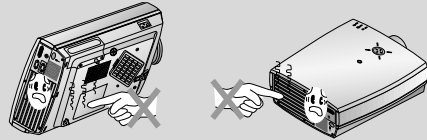

Never touch the wall outlet when there is leakage of gas, open the windows and ventilate.

- It can cause a fire or a burn by a spark.

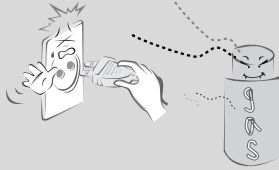

⚠ Using-NOTES

Do not drop the projector or allow impact shock.

- This may cause mechanical failure or personal injury !



Do not place heavy objects on top of projector.

- This may cause mechanical failure or personal injury!

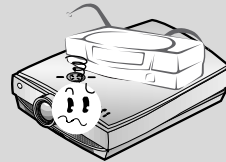

Take care not to cause impact to the lens particularly when moving the projector.

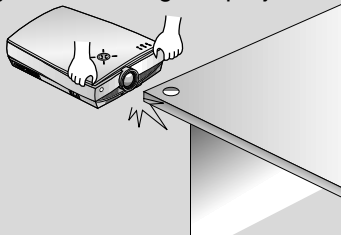

Safety Instructions



Using-NOTES

Do not touch the lens of the projector. It is delicate and easily damaged.

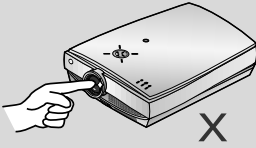

Do not use any sharp tools on the projector as this will damage the casing.

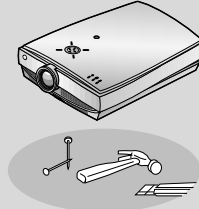

Cleaning-WARNING

Do not use water while cleaning the projector

- This may cause damage to the projector or an electric shock hazard.



In the unlikely event of smoke or a strange smell from the projector, switch it off, unplug it from the wall outlet and contact your dealer or service centre.

- This may cause a fire or an electric shock hazard!

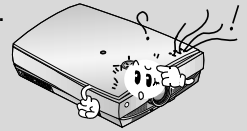

Use an air spray or soft cloth that is moist with a neutral detergent and water for removing dust or stains on the projection lens.

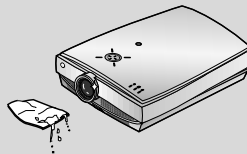

⚠ Cleaning-NOTES

Unplug this product from the wall outlet before cleaning. Do not use liquid cleaners or aerosol cleaners.

- This may cause damage to the Projector or cause an electric shock hazard !



Contact the Service Center once a year to clean the internal parts of the projector.

- Accumulated dust can cause mechanical failure.

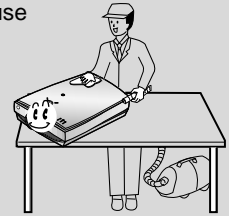

⚠ Others-WARNING

Do not attempt to service the projector yourself. Contact your dealer or service centre.

- This may cause damage to the projector and could give an electric Shock as well as invalidating the warranty !



If a receiver (VCR, Digital Set Top Box) is connected to the projector, in the event of lightning or thunder storm, unplug the projector and aerial from the wall outlet.

- This will prevent damage to the projector and possible electric shock.

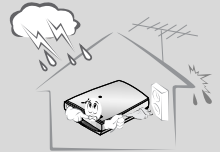

⚠ Others-NOTES

Be sure to unplug if the projector is not to be used for a long period.

Accumulated dust may cause a fire hazard!



Refer lamp servicing to qualified service personnel.

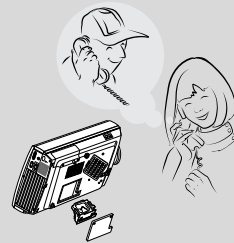

Do not mix new batteries with old batteries.

- This may cause the batteries to overheat and leak.

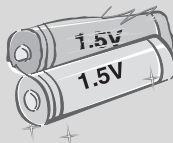

Only use the specified type of battery.

- This could cause damage to the remote control.

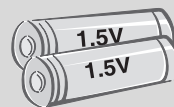

Names of parts

Main Body

* The LCD projector is manufactured using high-precision technology. You may, however, see on the Projector screen tiny black points and/or bright points (red, blue, or green). This can be a normal result of the manufacturing process and does not always indicate a malfunction.

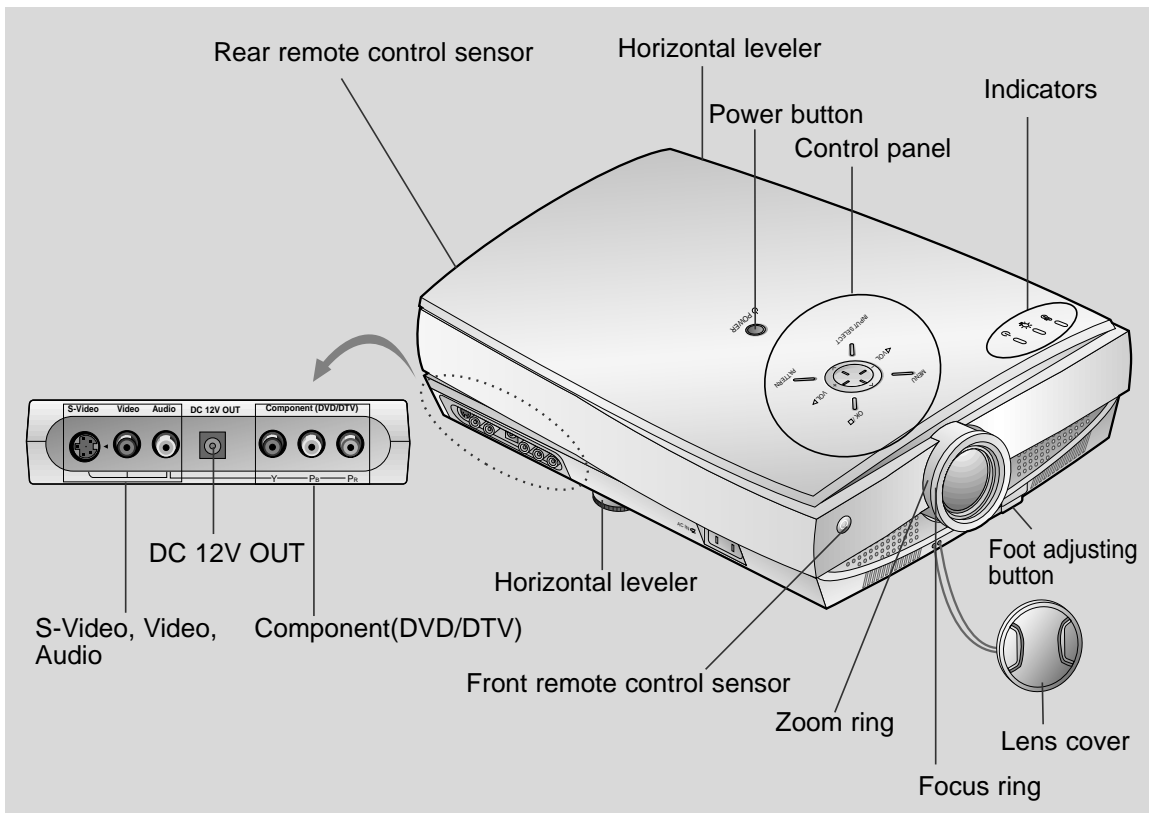

Rear Connecting Part

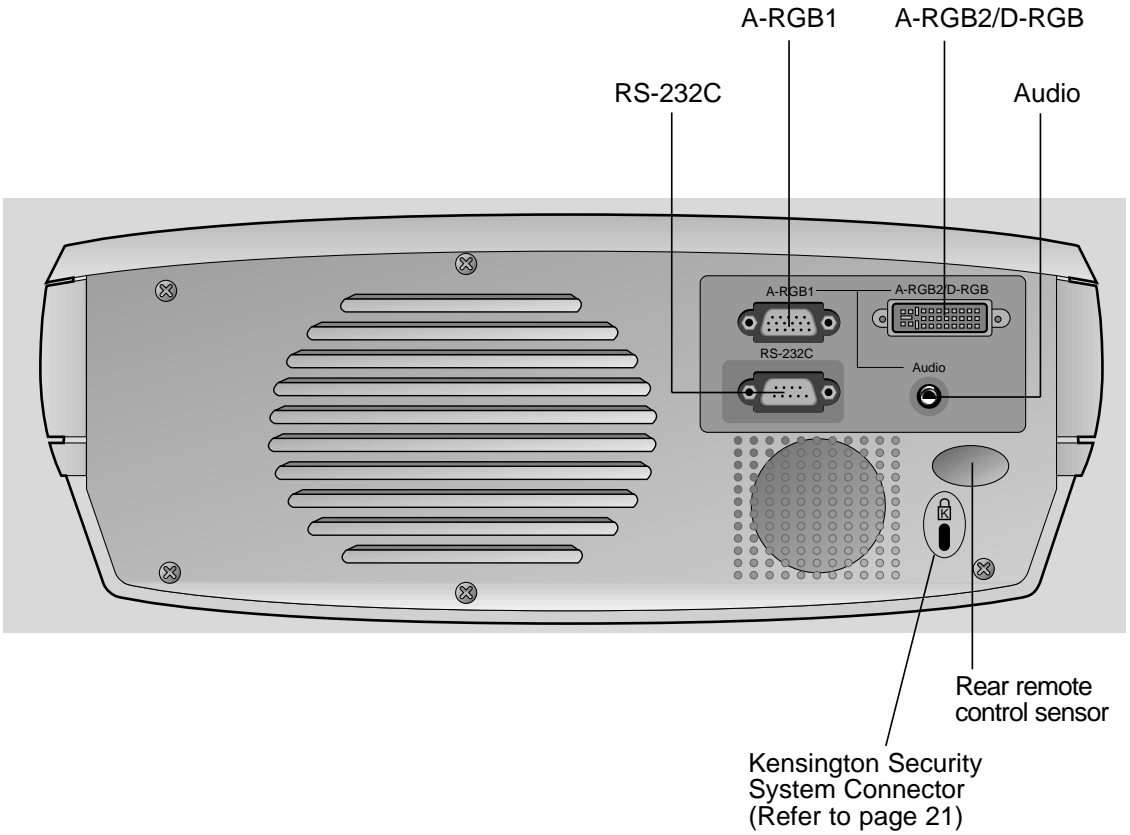

Control Panel

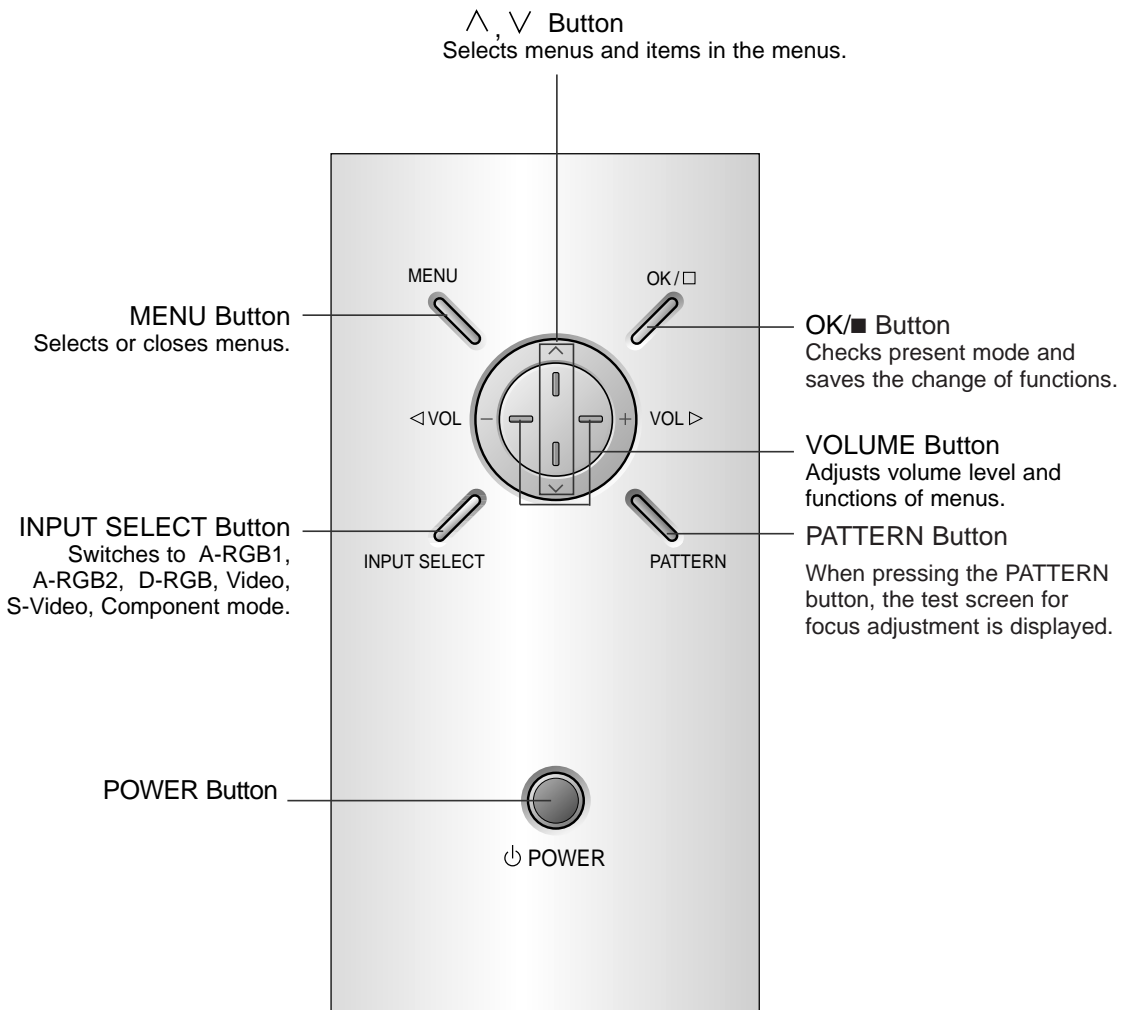

Remote Control

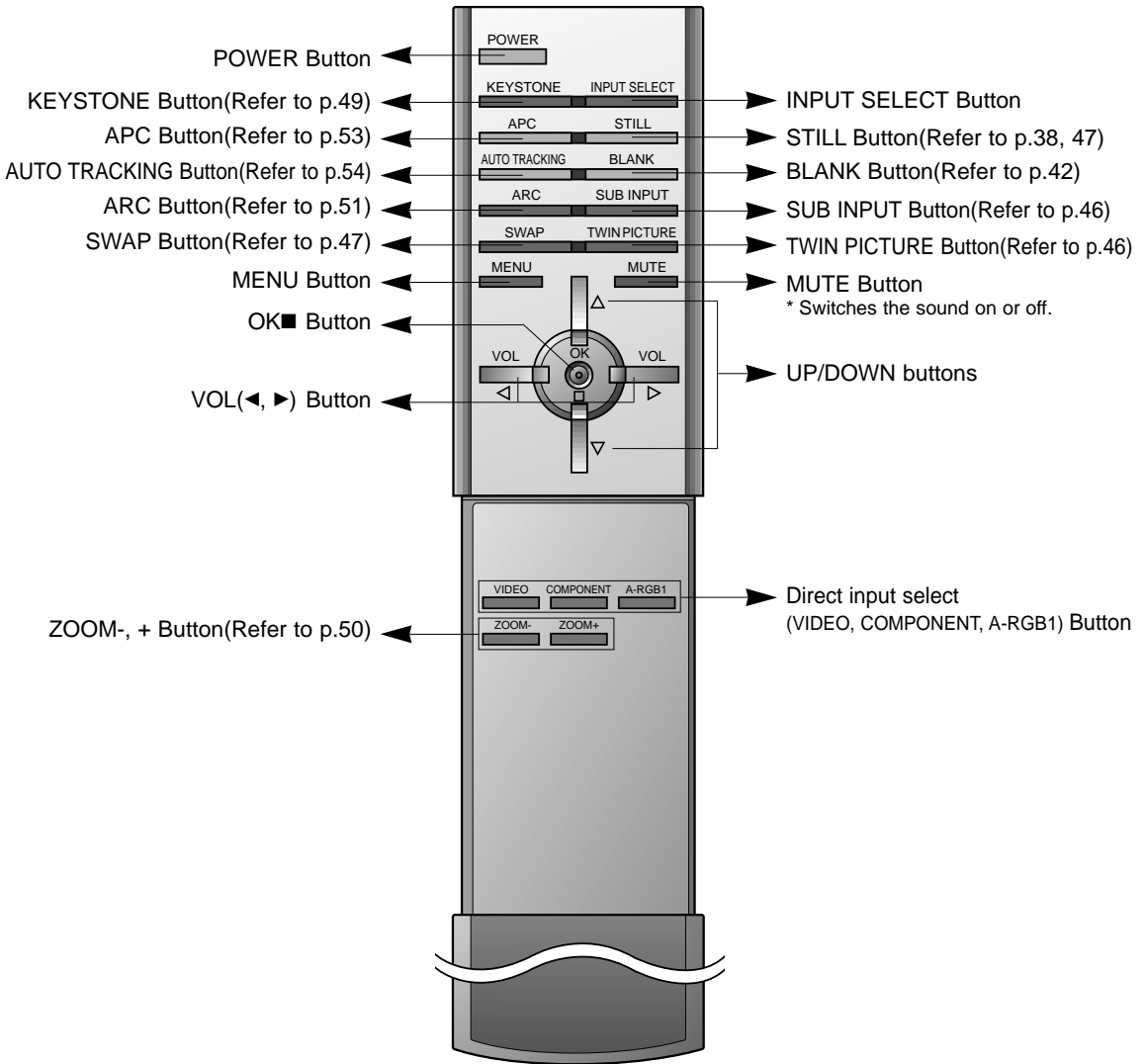

Inserting the batteries

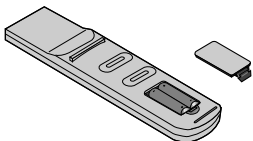

- Open the battery compartment cover on the back of the remote control and insert the batteries with correct polarity, match "+" with "+", and match "-" with "-".
- Install two 1.5V "AAA" alkaline batteries. Don't mix used batteries with new batteries.

Projector Status Indicators

* Lamp Indicator, operation indicator and temperature indicator at the top of the projector show the user the operating status of the projector.

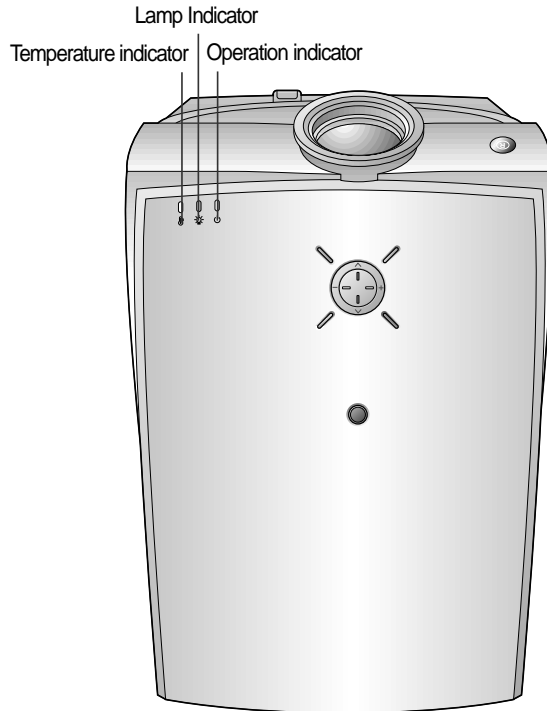

Operation Indicator	Red	Initializing hardware after the main power applied.
	Orange	Standby.
	Green	On operation.(Turn on the lamp)
	Orange(flashing)	Projector lamp is cooling as power out(2 minutes)
	Off	Power off.
Lamp Indicator	Red	Projector lamp is reaching the end of its life and needs to be replaced with a new lamp.(over 1500 hours) The OSD, "Replace the Lamp" is displayed 10 seconds from the first power on.
	Red(flashing)	The projector has trouble in the lamp or around it at power-on. Retry Power On again later. If lamp indicator is red(flashing) again, contact the service center.
	Green(flashing)	The lamp cover or absorption pipe cover is not closed.
Temperature Indicator	Orange	This projector is in high temperature. If you don't turn off the projector, it'll be turned off automatically. "Temperature is Too High"
	Red	The projector is turned off as its high temperature.
	Red (flashing)	Power has turned off due to problem with the internal cooling fan. Contact your service center.

" " is the warning message on screen.

Accessories



Remote Control

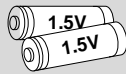

Batteries 2 (size AAA)



Power Cord



Audio/Video Cable



Audio Cable



Computer Cable



DVI Cable



SCART to RCA jack (option)

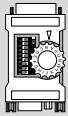

MAC Desktop
Adaptor

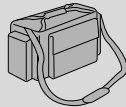

Portable Bag

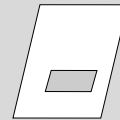

Operating guide

Optional Extras

* Contact your dealer to purchase these items.

* Contact your dealer for replacing a new lamp.

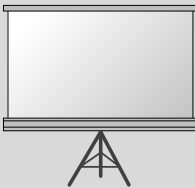

Projection Screen



S-Video Cable



DVI to VGA Cable



Lamp

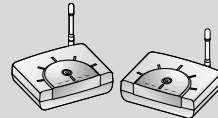

A/V wireless
transmitter-receiver

* See A/V wireless transmitter-receiver operating guide for installation and connection etc.

Installation Instructions

* Don't place the projector in the following conditions. It may cause malfunction or product damage.

Provide proper ventilation for this projector.

- The projector is equipped with ventilation holes(intake) on the bottom and ventilation holes(exhaust) on the front. do not block or place anything near these holes, or internal heat build-up may occur, causing picture degradation or damage to the projector.
- Do not place the projector on a carpet, rug or other similar surface. It may prevent a adequate ventilation of the projector bottom. This product should be mounted to a wall or ceiling only.

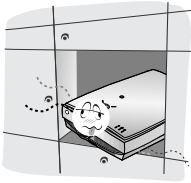

- Never push projector or spill liquid of any kind into the projector.
- Leave an adequate distance(30cm or more) around the projector.

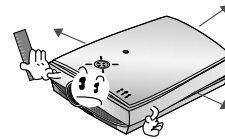
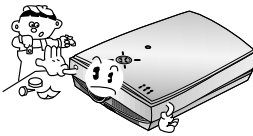

Place this projector in adequate temperature and humidity conditions.

- Install this projector only in a location where adequate temperature and humidity is available. (refer p.67)

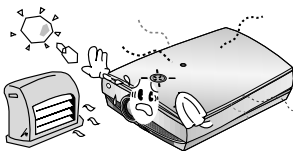

Don't place the projector where it can be covered with dust.

- This may cause overheating of the projector. Clean the Air filter periodically.

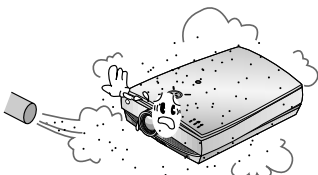

- **Do not obstruct the slots and openings of the projector. This may cause overheating and create a fire hazard.**

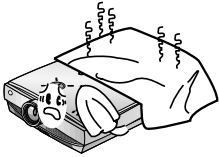

- **The LCD projector is manufactured using high-precision technology. You may, however, see tiny black points and/or bright points (red, blue, or green) that continuously appear on the LCD projector Screen. This is a normal result of the manufacturing process and does not indicate a malfunction.**

- **To display DTV programmes, it is necessary to connect a DTV receiver (Set-top Box) and connect it to the projector.**

- **If there is no input signal, the Menu will not be displayed on screen.**

Composition

Basic Operation of the Projector

1. Place the projector on a sturdy and horizontal surface with the PC or AV source.
2. Place the projector the correct distance from the screen. The distance between the projector and the screen determines the actual size of the image.
3. Position the projector so that the lens is set at a right angle to the screen. If the projector is not set at a right angle, the screen image will be crooked. If this is so then the keystone adjustment may correct this (Refer to page 49.)
4. Connect the cables of the projector to a wall power socket and other connected sources.

projection distance based on the picture format

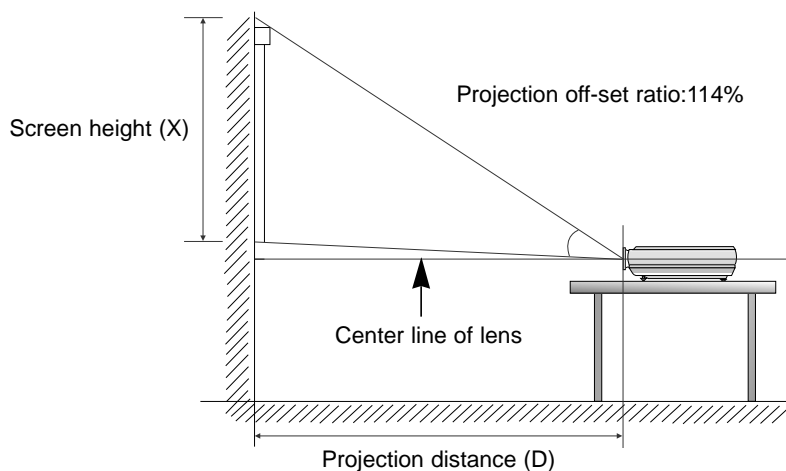

16:9 picture format									mm
screen size	40"	60"	80"	90"	100"	110"	120"	150"	200"
screen height (X)	498	747	996	1121	1245	1370	1494	1868	2491
The shortest distance (D)	1715	2572	3430	3859	4287	4716	5145	6431	8575
The longest distance (D)	2229	3344	4459	5016	5574	6131	6688	8361	11147

* The longest/shortest distance show status when adjusted by the zoom function.

4:3 picture format									mm
screen size	40"	60"	80"	90"	100"	110"	120"	150"	200"
screen height (X)	610	914	1219	1372	1524	1676	1829	2286	3048
The shortest distance (D)	2099	3148	4198	4722	5247	5772	6297	7871	10494
The longest distance (D)	2729	4093	5457	6139	6821	7503	8186	10232	13643

Using Kensington Security System

- The projector has a 'Kensington' Security System Connector on the back panel. Connect the 'Kensington' Security system cable as below.
- For the detailed installation and use of the Kensington Security System, refer to the user's guide attached to the Kensington Security System set. And for further information, contact <http://www.kensington.com>, the internet homepage of the Kensington company that deals with expensive electronic equipments such as notebook PCs or LCD projectors.
- Kensington Security System is an optional item.

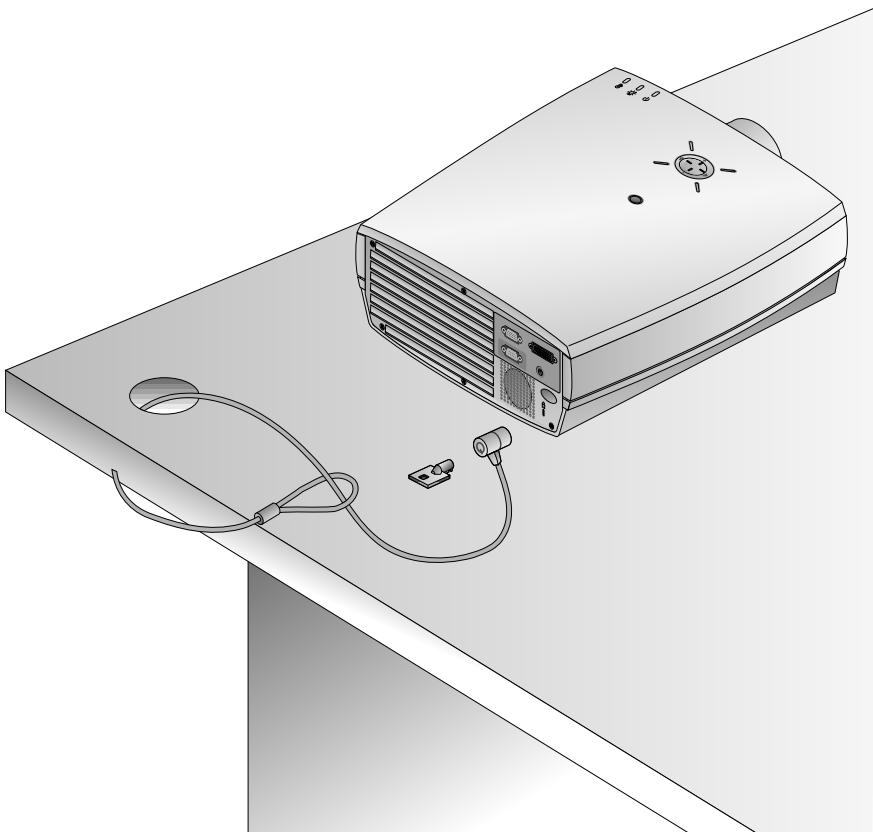

Turning on the Projector

1 Connect power cord correctly.

2 Remove the lens cover of the projector.

3 Press the **POWER** button on the remote control or top cover.(Green operation indicator flashes during cooling of the lamp.)

- It will take about 1 minute to display the picture after power on because the projector lamp has to warm up.
 - An image will appear after the operation indicator light up(Green).
 - Select the source mode with the **INPUT SELECT** button.
 - Leave the projector plugged in for at least 2 minutes after switching off the projector, as this will allow the lamp cooling to continue which will help to preserve the lamp life.
-

4 Adjust volume level.

- If you press **VOLUME** ► button, sound and volume level number are increased.
- If you press **VOLUME** ◀ button, sound and volume level number are decreased.

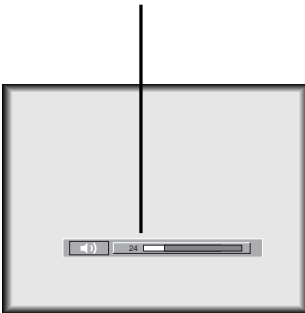

* Don't turn main power off and don't unplug the power cord while the ventilation fan(inlet/outlet) is working.

Turning off the Projector

- 1 Press the **POWER** button on the top cover or remote control.

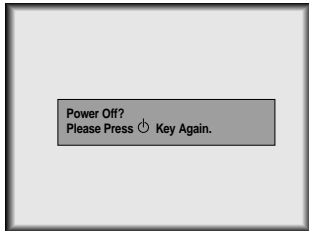

-
- 2 Press the **POWER** button on the top cover or remote control again to cut off the power.

-
- 3 If the operation indicator LED is orange and blinking, do not disconnect the mains supply until the operation indicator LED is lit up constantly (orange).
 - If the operation indicator LED is orange and blinking, the power button on the top cover or on the remote control will not operate.

Operating the Projector

Focus and Position of the Screen Image

When an image appears on the screen, check if it is in focus and fits well to the screen.

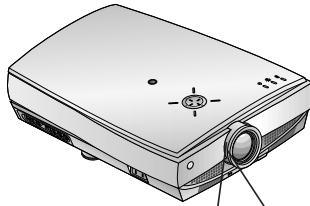

Zoom ring Focus ring

- To adjust the focus of the image, rotate the focus ring which is the outer ring on the lens.
- To adjust the size of the image, rotate the zoom ring which is the inner ring on the lens.

To raise or lower the image on the screen, extend or retract the foot at the bottom of the projector by pushing foot adjuster button as below.

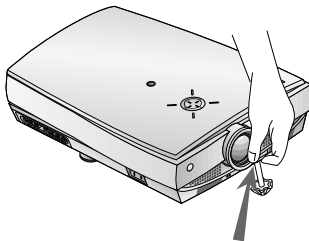

1. Stand behind the projector and lift the foot adjuster levers while you support the front of the projector.
2. While pressing the foot adjuster button, raise or lower the projector to place the screen image in the proper position.
3. Release the button to lock the foot in its new position.
4. To fine-tune the height of the projector, rotate the front foot to raise or lower it. After raising the front foot, do not press down on the projector.

If the projector is installed on a place that is not stable or horizontal, the projected screen shape will be distorted.

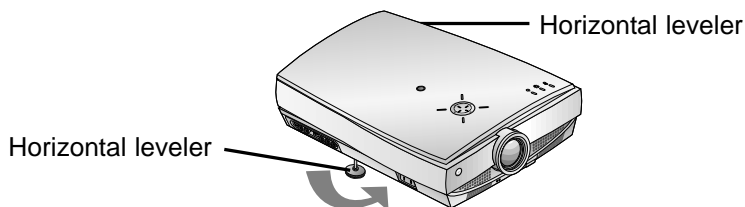

- Adjust the screen shape to be horizontal and rectangular with horizontal leveler as above.
- Avoid impact or extra weight on top of the projector as it may cause the feet to alter position or damage them.

Selecting source mode

- 1 Press the **INPUT SELECT** button.



- 2 Each press of the **VOLUME** (◀, ▶) button changes the display as below.

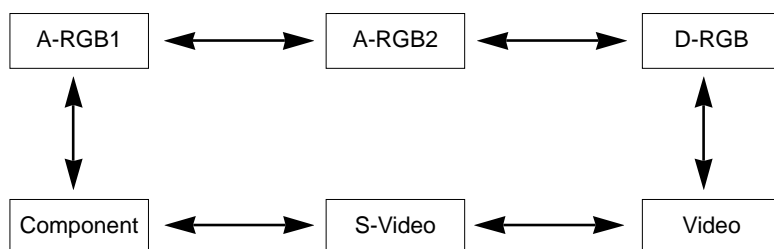

Connecting to a Desktop PC

- * You can connect the projector to a computer of VGA, SVGA, XGA and SXGA output.
- * You can use ARC function for the RGB signals of the Aspect Ratio 4:3. (For HD wide input signals, you cannot use ARC function.)
- * Fundamentally, HD wide input signal is not included in the Spec, so the set may not support HD signal perfectly.
- * Refer to page 63 for the supported pc graphic card displays of the projector.

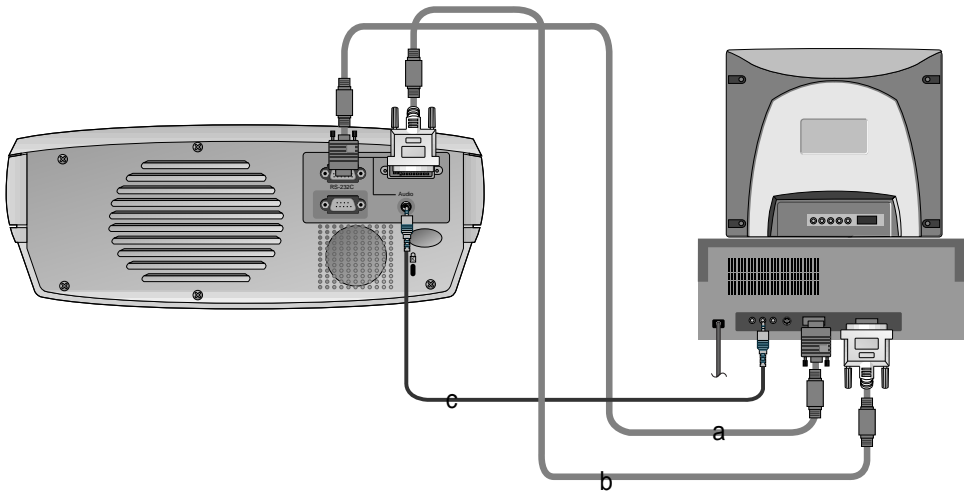

< How to connect >

- Connect computer cable to **A-RGB1** of the projector.
- If the PC has DVI output, connect DVI cable to **A-RGB2/D-RGB** of the projector.
- Connect the audio cable of PC (LINE OUT sound port) to **Audio** of the projector.
* If the PC has two audio out ports of SPEAKER OUT and LINE OUT, connect the LINE OUT port to get better sound quality.

Connecting to a Notebook PC

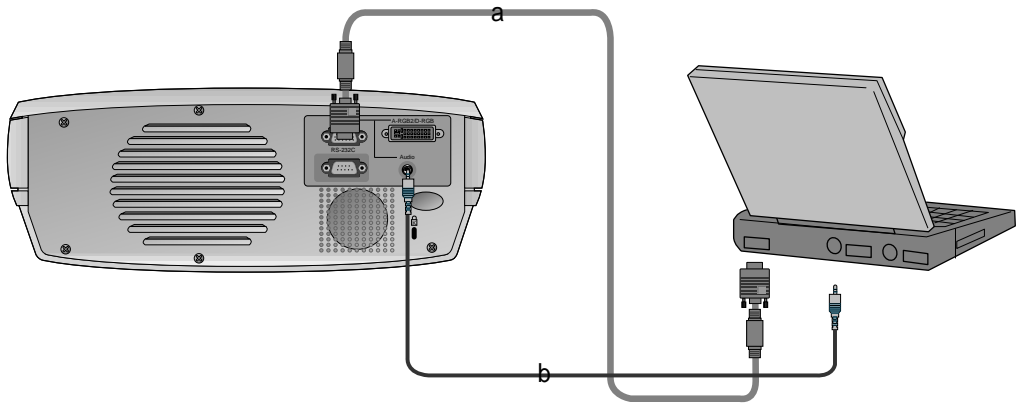

< How to connect >

- a. Connect computer cable to **A-RGB1** of the projector.
 - * If you set your computer, such as a notebook type IBM PC/AT compatible, to output the signal to both the display of your computer and the external monitor, the picture of the external monitor may not appear properly. In such cases, set the output mode of your computer to output the signal only to the external monitor. For details, refer to the operating instructions supplied with your computer.
 - * If the PC has DVI output, use DVI cable.

- b. Connect the audio cable of PC (LINE OUT sound port) to **Audio** of the projector.

Connecting to a Macintosh Desktop PC

* You must use the Macintosh desktop adaptor to connect the projector to a Macintosh PC.

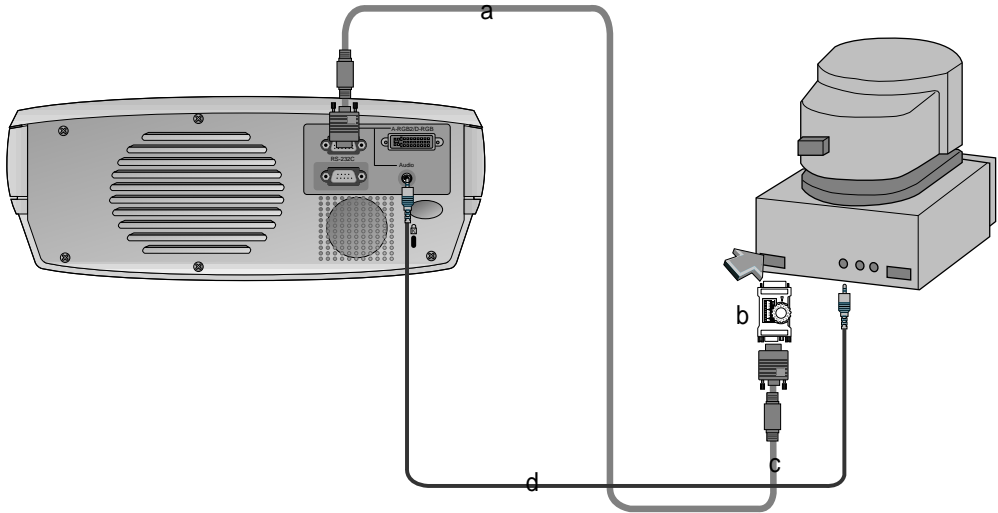

< How to connect >

- a. Connect computer cable to **A-RGB1** of the projector.
- b. Set the adjusting number and letter of the Macintosh desktop adaptor in accordance with the resolution you want to use and connect the adaptor to the Macintosh. (Refer to page 29 ~ 30)
- c. Connect the computer cable to the Macintosh desktop adaptor.
- d. Connect the audio cable of PC (LINE OUT sound port) to **Audio** of the projector.

How to use the Macintosh desktop adaptor

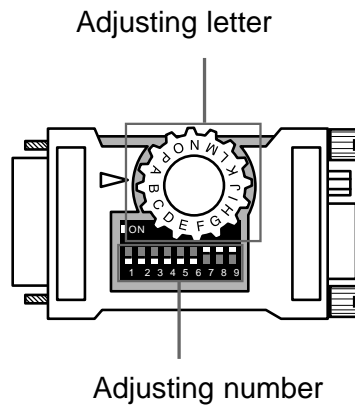

- a. **How to use**
Usually set 1 ~ 6 to OFF status and 7 ~ 9 to ON status of the adjusting numbers. And select the adjusting letter which is correct to the Macintosh and the monitor. (Refer to page 30.)
- b. **Notes for Connecting to the Macintosh PowerBook**
If you get problems when connecting it to the projector, set the adjusting number 9 to OFF status and restart the Macintosh PowerBook.

Connecting to a Macintosh Desktop PC

Adjusting letters of MAC desktop adaptor in accordance with type of MAC and output spec.

M.A.C.S	output spec	output resolution		12"RGB	13"14"RGB	15"Portrait	VGA	SVGA	SVGA	16"Color	19"Color	19"Color	2Page Mono	21"Color	NTSC	PAL
	horizontal frequency(KHz)	vertical frequency(Hz)	512x384	640x480	640x870	640x480	800x600	800x600	832x624	1024x768	1024x768	1150x870	1152x870	NTSC	PAL	
	adjusting letter	N	J	O	G	G	G	G	F	D	G	M	P	L	H	
MAC Ixi, Ixi		N	J	O												
MAC Ivi, Ivi		N	J		G											
LC		N	J		M											
LCII		N	J		G											
LCIII		N	J	O	G				F							
LC 475, LC 550		N	J	O	G	G			F							
LC 575		N	J	O	G	G			F	D		M	P	L	H	
Performa																
400,405,410,430,600,600CD		N	J		G											
450		N	J	O	G				F							
Quadra																
700,900		N	J	O	G	G			F			M	P	L	H	
605,610,650,800,950		N	J	O	G	G			F	D		M	P	L	H	
840AV		N	J	O	G	G	G		F	D	G	M	P	L	H	
Centris																
610,650		N	J	O	G	G			F	D		M	P	L	H	
660AV		N	J	O	G	G	G		F	D	G	M	P	L	H	
PowerBook																
160,165C,180,180C		N	J	O	G	G			F							
DUO DOC, MINI DOC		N	J	O	G	G			F							
8 24 BOARD		N	J	O					F			M	P	L	H	

Connecting to a Macintosh PowerBook

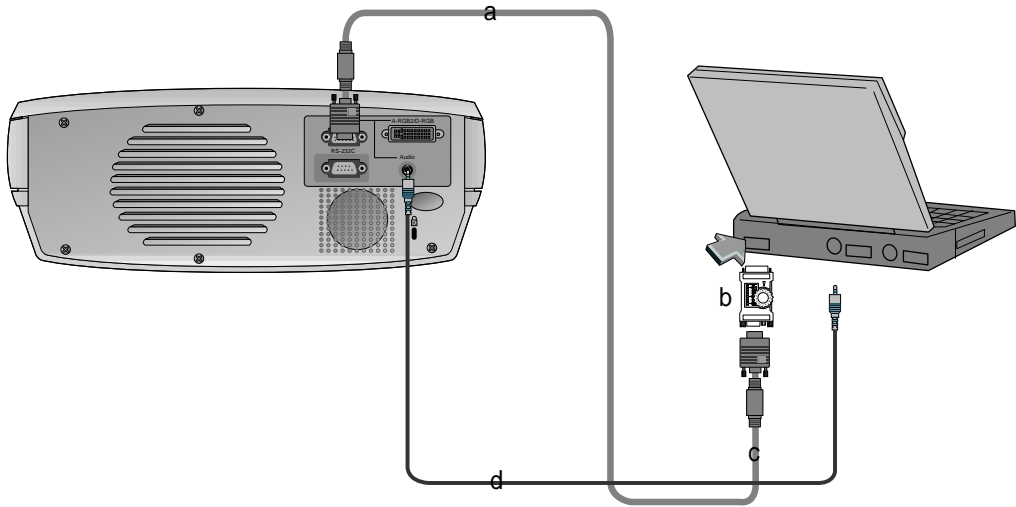

< How to connect >

- a. Connect computer cable to **A-RGB1** of the projector.
- b. Set the adjusting number and letter of the Macintosh desktop adaptor in accordance with the resolution you want to use and connect the adaptor to the Macintosh. (Refer to page 29 ~ 30)
- c. Connect the computer cable to the Macintosh desktop adaptor.
- d. Connect the audio cable of PC (LINE OUT sound port) to **Audio** of the projector.

Connecting to a wireless transmitter (option)

- When connecting the wireless transmitter with external equipments, match the colors of connecting ports (Video - yellow, Audio(L) - white, Audio(R) - red).
- If you have a mono VCR, connect the audio cable from the VCR to the AV input of the wireless AV transmitter.
- See the wireless transmitter-receiver operating guide for installation and connection etc.

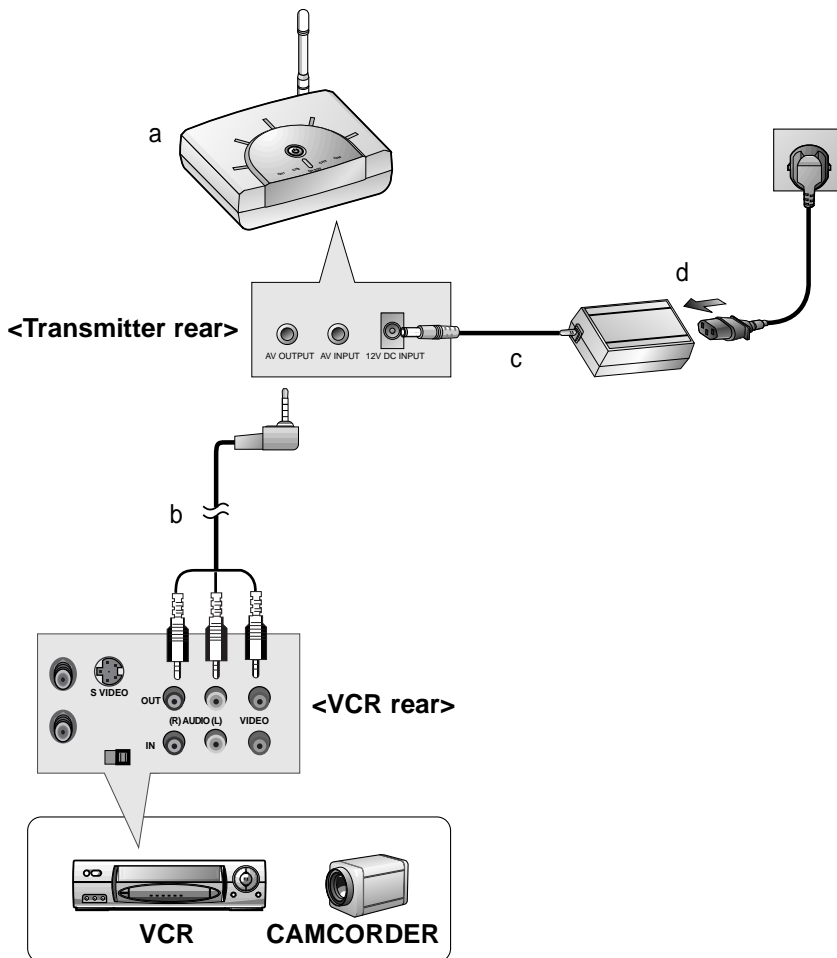

< How to connect >

- Turn on the transmitter power and set the desired channel with channel button and direct the wireless AV transmitter toward the wireless receiver.
- Connect the output jacks of the VCR to the AV OUTPUT jacks of the wireless AV transmitter.
- Connect the adaptor to the DC input of the wireless AV transmitter .
- Connect the power plug to the wall outlet socket after connecting the power cord to the adaptor.

Connecting to a wireless receiver (option)

- When connecting the wireless receiver with external equipment, match the colors of connecting jacks: Video-yellow, Left Audio-white, Right Audio-Red.

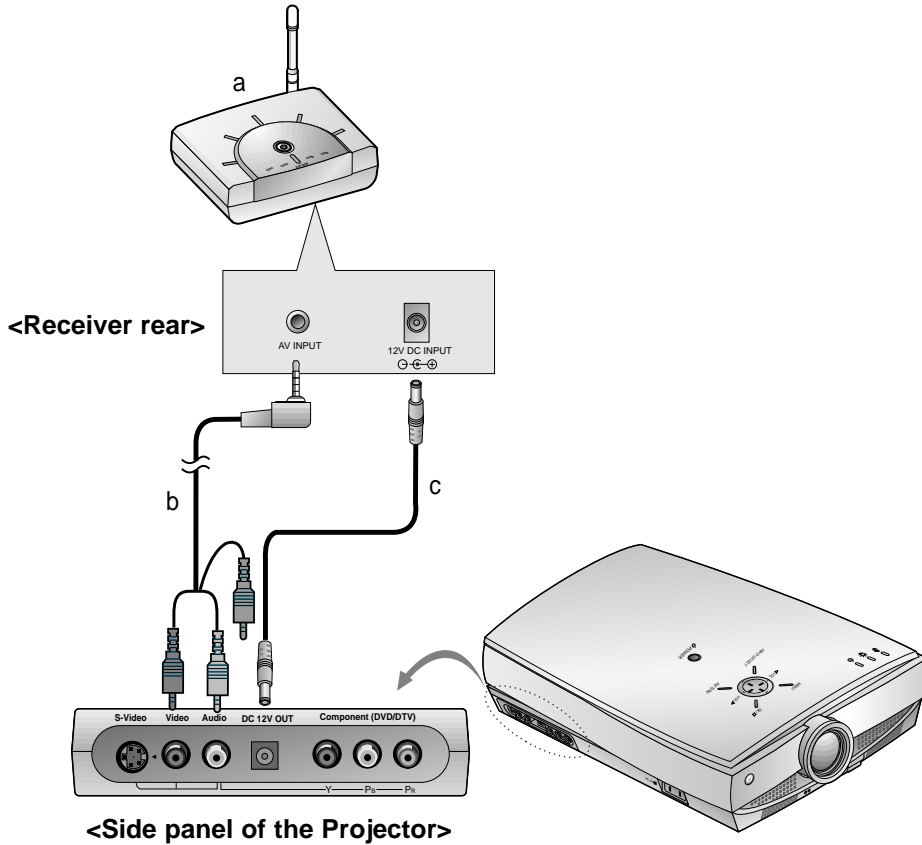

< How to connect >

- Turn the power button of the receiver on, and adjust the channel number to match the channel number of the transmitter, with the channel button. Direct the wireless AV receiver toward the wireless transmitter.
- Connect the AV input ports of the projector to the AV INPUT port of the receiver.
- Connect the DC output of the projector to the DC input of the wireless receiver with the DC cable.

Connecting to a Video Source

* You can connect a VTR, a camcorder, a LDP or any other compatible video image source to the projector.

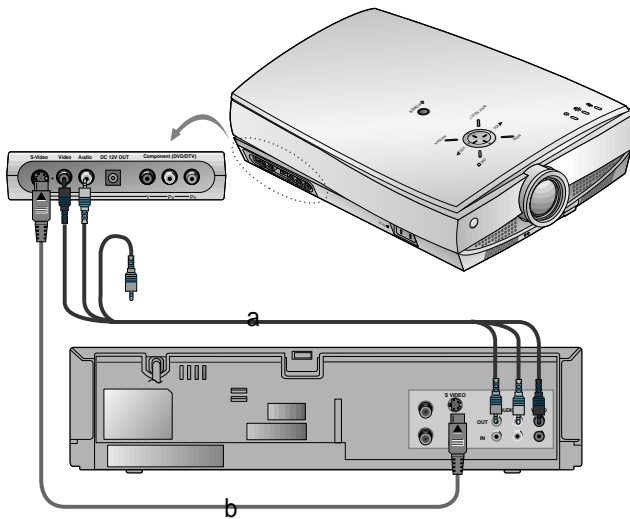

< How to connect 1 >

- Connect the AV input jacks of the projector to the output jacks of the A/V source with A/V cables. If you connect the Audio(R) of external equipment with projector, you can't hear the sound. The video cable is yellow and the left audio is white and right audio is red.

< How to connect 2 >

- Connect the S-Video input jack of the projector to the S-Video output jack of an A/V source with an S-Video cable.
Connect the Audio input jacks of the projector to the output jacks of the A/V source with an Audio cable.
* You can get better picture quality when connecting S-Video source to the projector.

Connecting to a DVD

* The output jacks (Y, Pb, Pr) of the DVD might be labelled as Y, Pb, Pr / Y, B-Y, R-Y / Y, Cb, Cr according to the equipment.

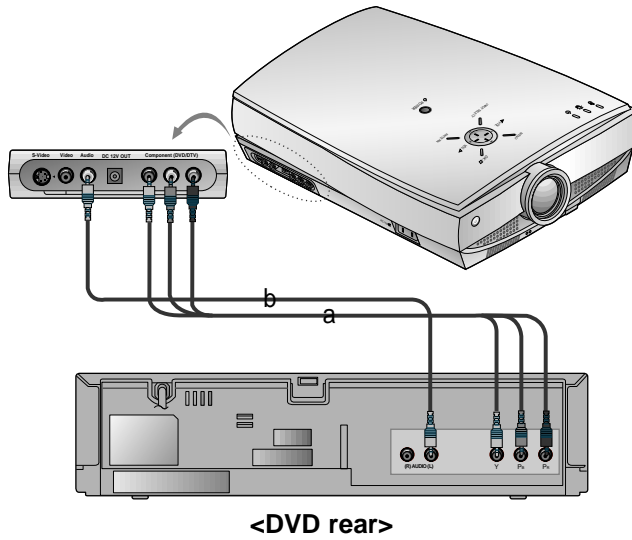

< How to connect >

- Connect the **Component (DVD/DTV)** ports (**Y, Pb, Pr**) of the projector to the Video output ports (**Y, Pb, Pr**) of the DVD.
- Connect the **Audio** port of the projector to the Audio output port (**L**) of the DVD.
- Use a DVD with Component 480i(576i)/480p mode.

Connecting to a D-TV Set-Top Box

- * To receive D-TV programmes, it is necessary to purchase a D-TV receiver (Set-Top Box) and connect it to the projector.
- * Please refer to the owner's manual of the D-TV Set-Top Box for the connection between LCD projector and D-TV Set-Top Box.
- * Use a D-TV receiver with DTV 720p/1080i mode.

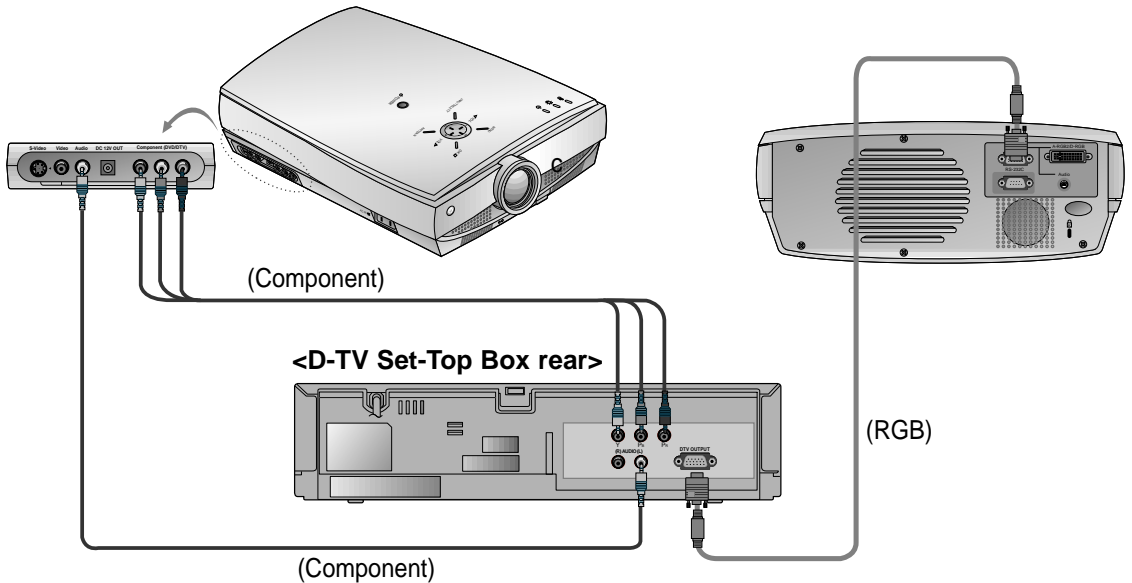

< How to connect an RGB source >

- Connect computer cable to **A-RGB1** of the projector.
* If the Set-Top Box has DVI output, use DVI cable.
- Use a DTV receiver with DTV 720p/1080i mode.

< How to connect a Component source >

- Connect the **Component (DVD/DTV)** ports (**Y**, **PB**, **PR**) of the projector to the Video output ports (**Y**, **PB**, **PR**) of the D-TV Set-Top Box.
- Connect the **Audio** port of the projector to the Audio output port (**L**) of the D-TV Set-Top Box.
- Use a DTV receiver with DTV 480p/720p/1080i mode.

Function checking

* If there is no input signal present, the Menu will not be displayed on the screen.

* This operating guide explains operation of A-RGB1 mode mainly.

1 Press the **MENU** button to display a menu on the screen.

2 Press the **▲, ▼** button to select a menu.

- Each press will cycle through the different menus as shown below.

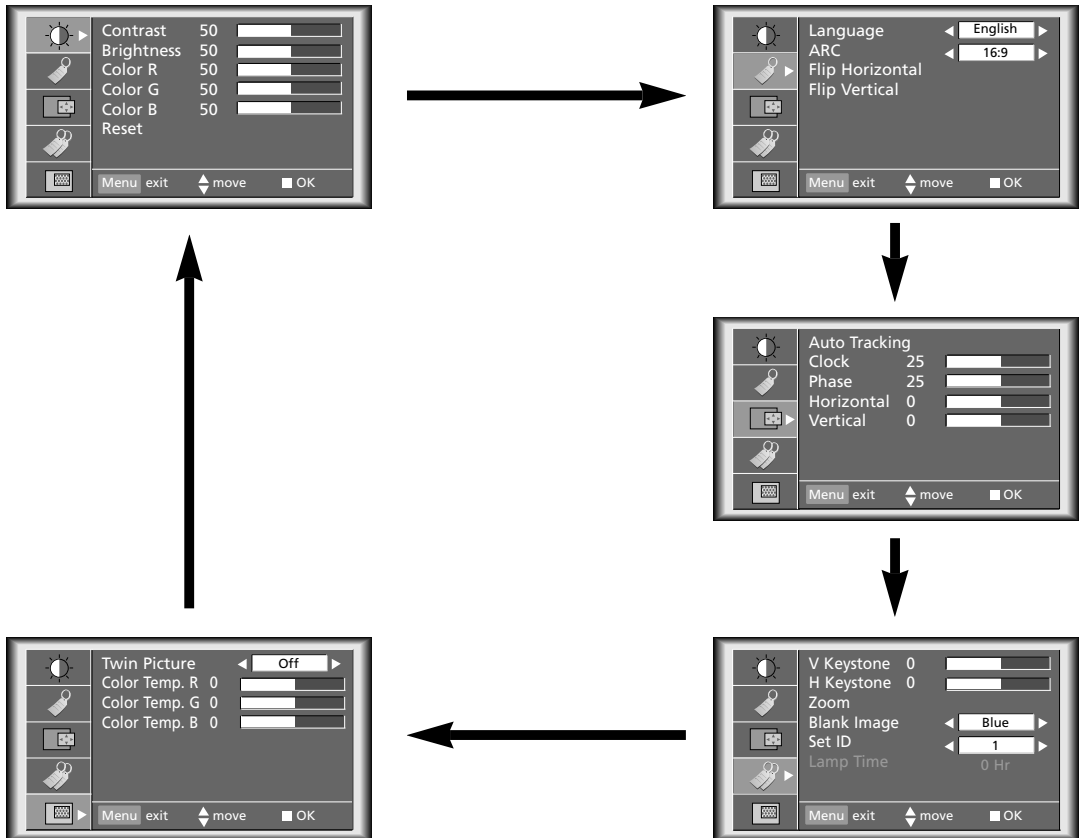



BASIC FUNCTIONS

3 Press the **OK** (■) button and then press the **▲, ▼** or **VOLUME** (◀, ▶) buttons to select a feature you want to use.

- To exit the menu display, press the **MENU** button.

* In Video and S-Video mode and Component(480i(576i)), D-RGB mode  menu is not displayed.

* Only A-RGB1, A-RGB2, Component(480p, 720p, 1080i) mode displays [**Horizontal**], [**Vertical**] in  menu

* The sub menus of  menu in Video and S-Video mode and Component mode are different from those in the RGB mode. (Refer to page 52).

* [**Color R**], [**Color G**], [**Color B**] : Use only for the A-RGB1 and the A-RGB2 modes. [**Color R**], [**Color G**], [**Color B**] items are used to adjust the R/G/B color levels when the RGB analog input signal has improper R/G/B signal levels.

Using Still function

- 1 Press the **STILL** button.
* You can freeze the input image.

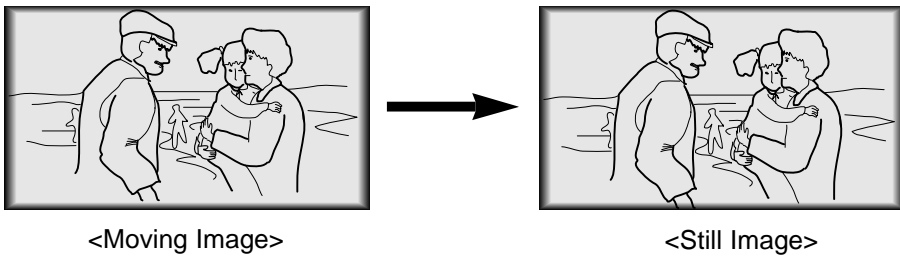

-
- 2 To exit Pause, press any button .
* The STILL function would release automatically after about 10 minutes.

Selecting language

- 1 Press the **MENU** button and then use ▲ / ▼ button to select the  menu.

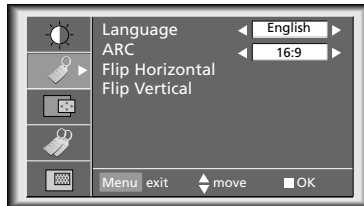

- 2 Press the **OK** (■) button and then use ▲ / ▼ button to select [Language] item.

- 3 Press the **VOLUME** (◀, ▶) button to select the language you want to use.
 - On-Screen-Display(OSD) is marked in the selected language from this point.
 - To exit the menu display, press the **MENU** button.

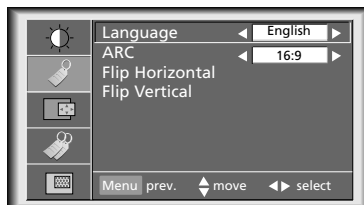

Checking lamp time

- 1 Press the **MENU** button and then use ▲ / ▼ button to select the  menu.

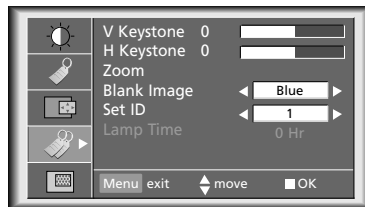

- The used lamp time is displayed.
- When projector lamp is reaching the end of its life(over 1500 hours), the lamp indicator will be turned red and the projector will display "Replace the Lamp" on screen.
- The OSD, "Replace the Lamp" is displayed for 10 seconds from the first power on.
- The lamp warning LED illuminates red continuously in the case of excessive lamp time.

Manual Color Temperature Control

* You can adjust red, green, or blue to any color temperature you prefer.

- 1 Press the **MENU** button and then use ▲ / ▼ button to select the  menu.

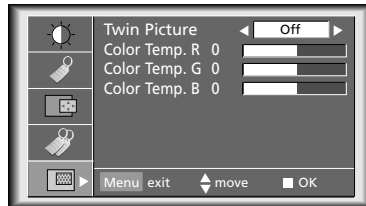

- 2 Press the **OK** (■) button and then use ▲ / ▼ button to select a color.

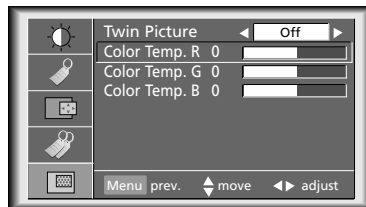

- 3 Use the **VOLUME** (◀, ▶) button to make appropriate adjustments.

- The adjustment range of [Color Temp. R], [Color Temp. G] and [Color Temp. B] is -50 ~ +50.
- To exit the menu display, press the **MENU** button.

Using Blank function

* This function may be effective if you need to get attention of the audience during presentations, meetings or briefings.

1 Press the **BLANK** button.

* The screen turns off to a background color and sound also turns off.

* You can choose the background color. Refer to page 43.

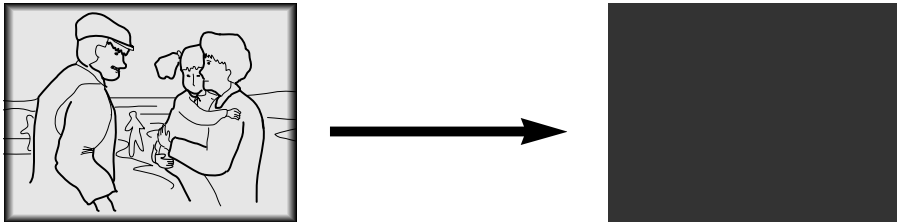

2 Press any button to cancel the blank function.

* On exiting the blank status sound is also restored.

Selecting Blank Image color

- 1 Press the **MENU** button and then use ▲ / ▼ button to select the  menu.

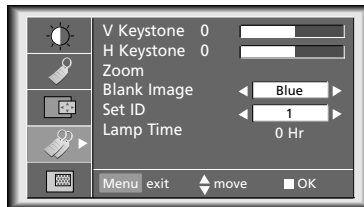

- 2 Press the **OK** (■) button and then use ▲ / ▼ button to select [**Blank Image**] item.

- 3 Press the **VOLUME** (◀, ▶) button to select the color you want to use.

- Background color will be changed to the selected Blank function color from this point.
- To exit menu display, press the **MENU** button.

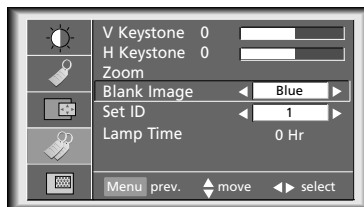

Using Flip Horizontal / Vertical function

Flip Horizontal Function

* This function reverses the projected image horizontally. Use this function when rear projecting an image.

- 1 Press the **MENU** button and then use ▲ / ▼ button to select the  menu.

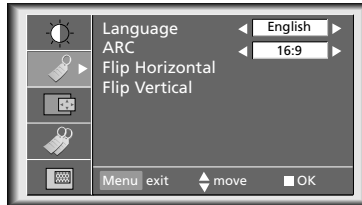

- 2 Press the **OK** (■) button and then use ▲ / ▼ button to select [Flip Horizontal] item.



- 3 Press the **OK**(■) button to see reversed image.

- Each time you press the button, the image will be reversed.
- To exit the menu display, press the **MENU** button.

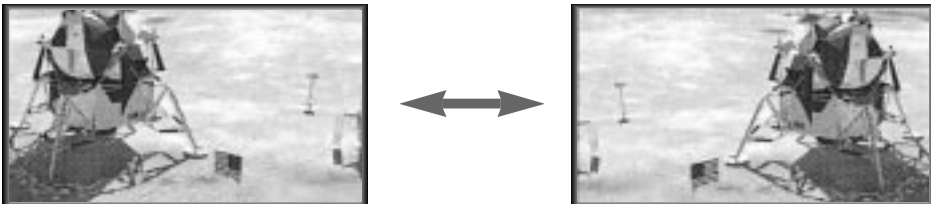

Flip Vertical Function

- * This function reverses the projected image vertically.
- * When you hang the projector upside down from the ceiling, you will need to reverse the image vertically and horizontally.

1 Press the **MENU** button and then use ▲ / ▼ button to select the  menu.

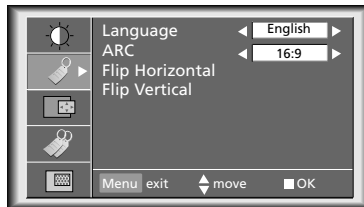

2 Press the **OK** (■) button and then use ▲ / ▼ button to select [**Flip Horizontal**] item.



3 Press the **OK**(■) button to see reversed image.

- Each time you press the button, the image will be reversed.
- To exit the menu display, press the **MENU** button.

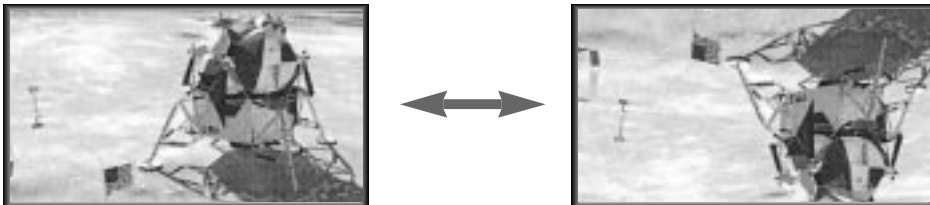

Twin Picture function

How to use twin picture

TWINPICTURE



Press the **TWIN PICTURE** button to select desired with picture.

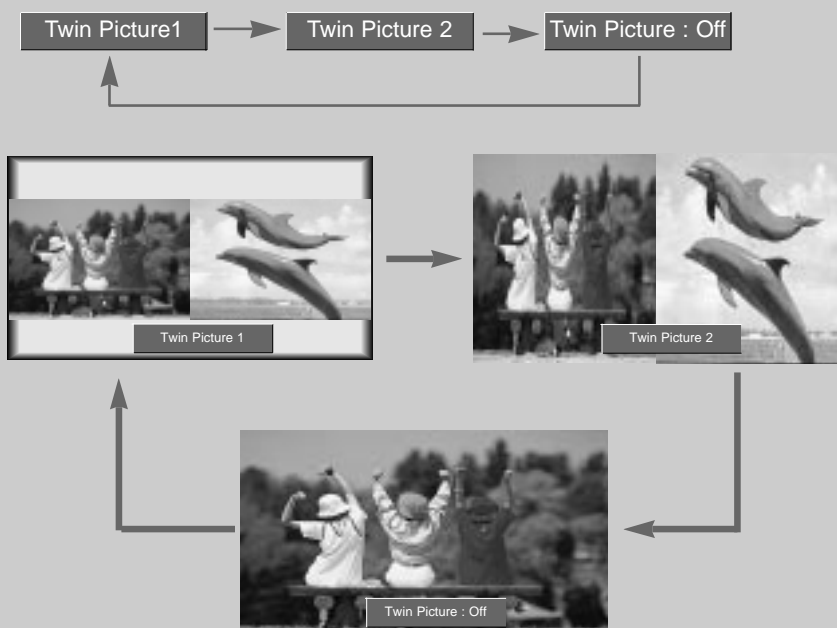

- You can use this function by using the **MENU** button.

Input select of the sub picture

SUB INPUT



Press the **SUB INPUT** button to select the input source of sub picture.

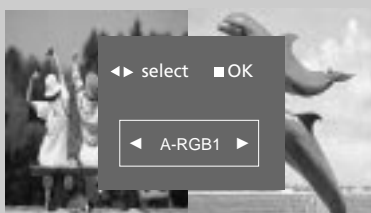



Changing the picture of main and sub picture

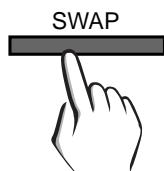

Press the **SWAP** button in twin picture mode.



Using Still function in twin picture mode.

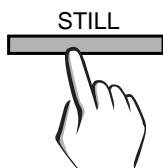

Press the **STILL** button in twin picture mode.



- You can cancel this function directly by selecting [Off] in menu.
- The STILL function is cancelled when changing the input signal.
[Main Still] is cancelled when changing the input signal with **INPUT SELECT** button and [Sub Still] is cancelled when changing the input signal with **SUB INPUT** button. That is, [Main/Sub Still] work separately.
- The STILL function would release automatically after about 10 minutes.

Adjusting screen display

* If the image size does not fit the screen in accordance with the input source, set the position of the image by selecting Horizontal / Vertical position.(For A-RGB1, A-RGB2, Component 480p/720p/1080i)

- 1 Press the **MENU** button and then use ▲ / ▼ button to select the  menu.

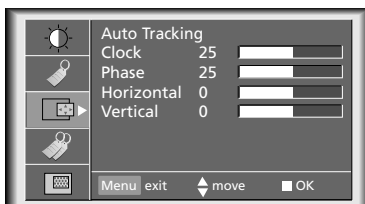

- 2 Press the **OK** (■) button and then use ▲ / ▼ button to select [**Horizontal**] or [**Vertical**] item.

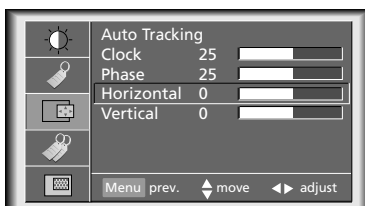

- 3 Press the **VOLUME** (◀, ▶) button to adjust the screen condition as you want.
 - [**Horizontal**], [**Vertical**] are adjusted from -50 to +50.
 - To exit the menu display, press the **MENU** button.

Using Keystone function

* Use this function when the screen is not at a right angle to the projector and the image is a trapezoid shape.

* Only use the **Keystone** function when you can't get the best angle of projection, because it may cause a blazing fire of the screen.

1 Press the **KEYSTONE** button.

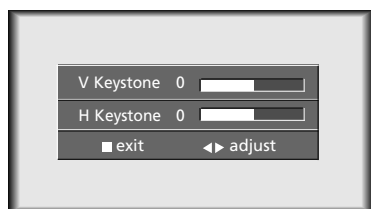

2 Press the ▲ / ▼ button to select [V Keystone] or [H Keystone] item.

3 Press the **VOLUME** (◀, ▶) button to adjust the screen condition as you want.

- [Keystone] are adjusted from -50 to +50.
- Adjustment range of H/V Keystone may not work until -50 ~ +50 because they are interlocked.
- Based on the input resolution or twin picture mode, the adjustment range of Keystone may be different.
- To exit the menu display, press the **OK** (■) button.
- You can also use this function by using the **MENU** button.

Using Zoom function

* This function works only in RGB mode.

- 1 Press the **ZOOM-** or **ZOOM+** button.

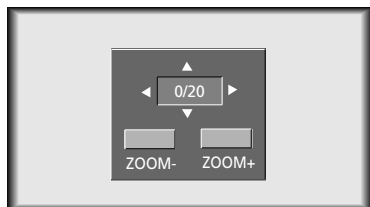

- 2 Press the **ZOOM-** or **ZOOM+** button to adjust the zoom level.

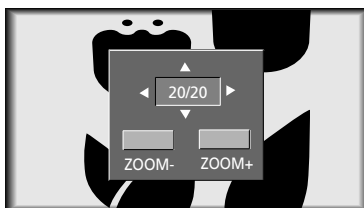
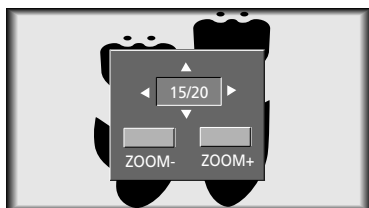

- 3 Move to the position you want to see the enlarged screen by moving press the **VOLUME** (◀, ▶), ▲, ▼ button.

- 4 Press the **OK** (■) or **ARC** button to exit the zoom function.



* This function doesn't work in Video, S-Video, Component mode.

* You can use this function by using the **MENU** button.

* In the zoom mode, you can adjust horizontal / vertical position with the **VOLUME** (◀, ▶), ▲, ▼ button during displaying zoom OSD.

Using ARC function

* You can select 16:9 picture format only with an HD input (720p,1080i) mode.

- 1** Press the **ARC** button.
Each press of the button changes the display as below.

< A-RGB1/A-RGB2/D-RGB mode >

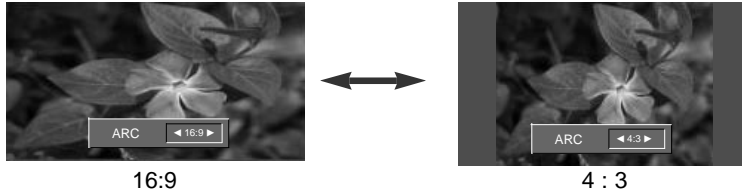

< Video/S-Video/Component(480i(576i), 480p) mode >

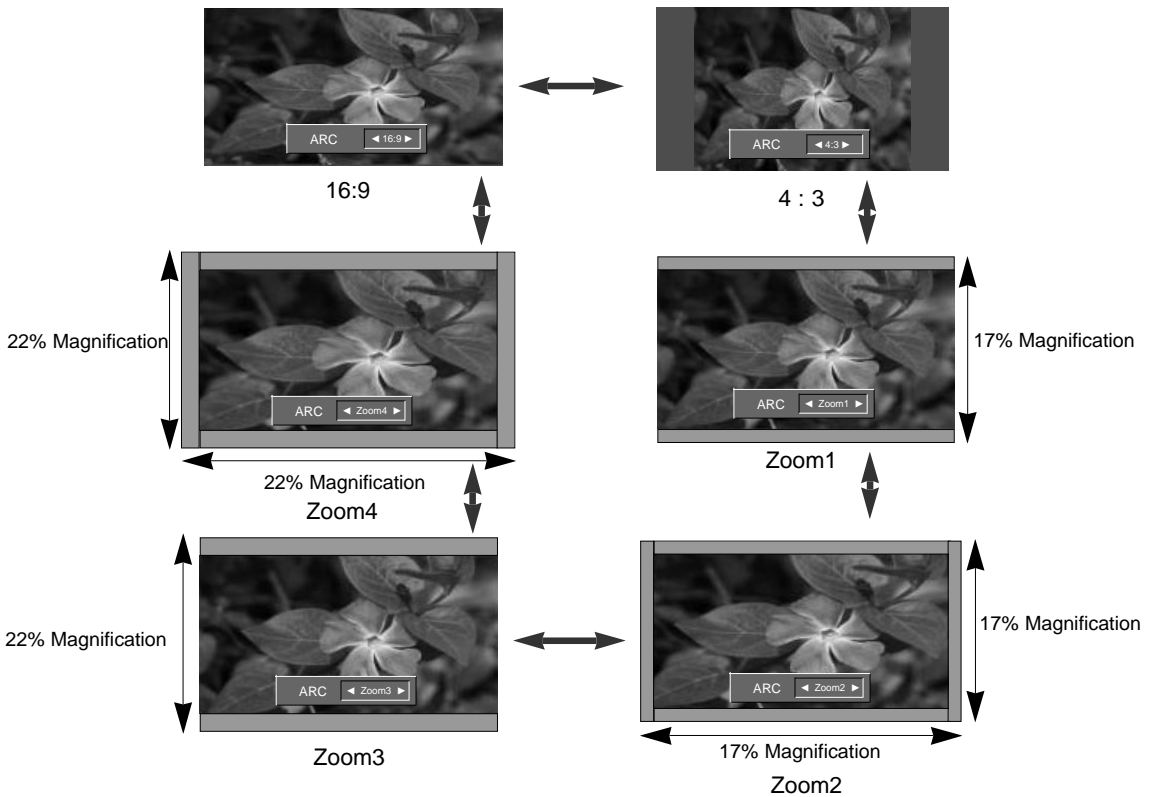

- * **Zoom1**
Select to stretch the normal image vertically (about 17%). Part of the top and bottom of the image will not be visible and black bars may appear at top and bottom of screen for some input sources.
- * **Zoom2**
Select to stretch the normal picture both vertically and horizontally (about 17%) to provide an enlarged and distortion free image.
- * **Zoom3**
Select to stretch the normal picture vertically (about 22% of original picture format).
- * **Zoom4**
Select to stretch the normal picture both vertically and horizontally (about 22%) to provide an enlarged and distortion free image.



* You can also use this function by using the **MENU** button.

Adjusting Video

1 Press the **MENU** button and move the ▲ / ▼ button up or down to select each  menu.

< RGB mode >

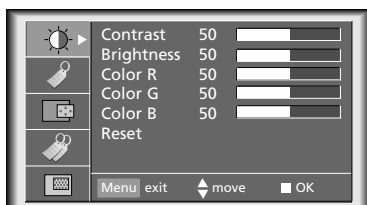

< Video, S-Video, Component mode >

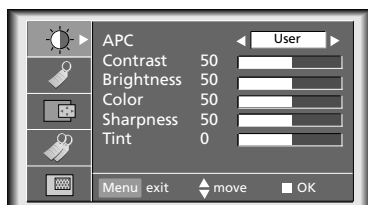

< Twin picture mode >

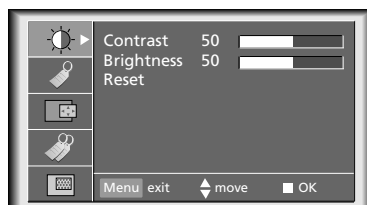

2 Press the **OK** (■) button.

< RGB mode >

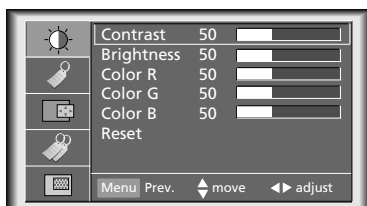

< Video, S-Video, Component mode >

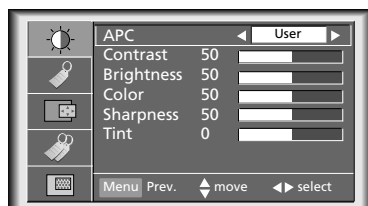

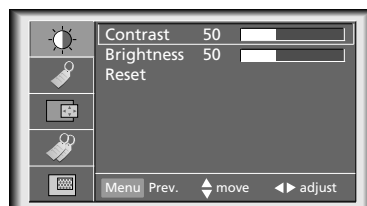

< Twin picture mode >



3 Press the ▲ / ▼ button up or down to select a video item you want to adjust.

4 Press the **VOLUME** (◀, ▶) button to adjust the selected video item as you want.

- You can only adjust **[Contrast]** and **[Brightness]** of  menu in Twin picture mode. In Twin picture mode, adjustment for **[Contrast]** and **[Brightness]** will not affect other input sources. Adjustments apply to main and sub picture simultaneously.
- Each adjustment of  menu options will not affect other input source. As required, re-adjust  menu options for the following input source : Video/S-Video/Component(480i(576i)), Component(480p, 720p, 1080i)
- To restore the original image condition after changing it, press **OK** (■) button after selecting **[Reset]** item.
- In the broadcasting system NTSC, the picture item **Tint** is displayed and can be adjusted.
- To exit the menu display, press the **MENU** button.

APC (Auto Picture Control)

- * Use APC to set the projector for the best picture appearance.
- * This function will not work in RGB mode.

1 Press the **APC** button.



2 Each press of the **APC** button changes the screen as shown below.

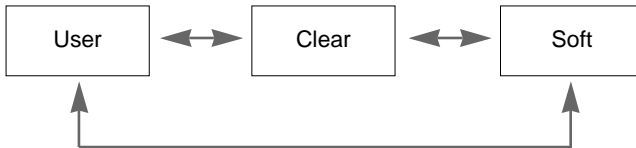

* You can also use this function by using the **MENU** button.
(Video/S-Video/Component mode)

Using Tracking function

Auto Tracking Function

* Auto Tracking Function

This function assures you of getting the best video quality by automatically adjusting the difference of horizontal size and synchronization of the image.

Auto Tracking function works in Analog RGB(A-RGB1, A-RGB2) input only.

- 1 Press the **AUTO TRACKING** button.



* Image positioning and synchronization are automatically adjusted.

- 2 Adjust [**Clock**] or [**Phase**] in  menu after operation of [**Auto Tracking**] if you want to get better picture quality in accordance with diverse Analog RGB(A-RGB1, A-RGB2) input modes. In certain circumstances, you can't get the best picture quality only with auto-correction. (Refer to page 55.)



* You can also use this function by using the **MENU** button.(Only in Analog RGB mode)

* For best results, perform this function while displaying a still image.

Clock / Phase Function

* Clock Function

This function adjusts the horizontal width of the projected image to get the image to fit on the screen size.

* Phase Function

This function is for the detailed adjustment of the clock function.

* It's available to adjust [Clock], [Phase] in Analog RGB mode only.

- 1 Press the **MENU** button and then use ▲ / ▼ button to select the  menu.

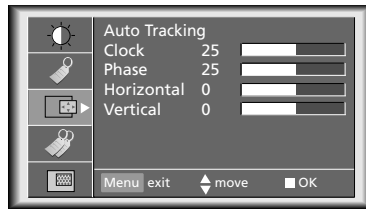

- 2 Press the **OK** (■) button and then use ▲ / ▼ button to select [**Clock**] or [**Phase**] item.

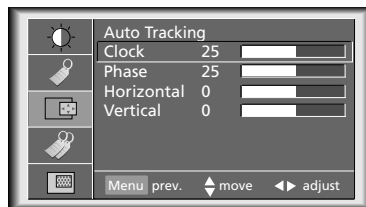

- 3 Press the **VOLUME** (◀, ▶) button to adjust the screen condition.
 - To exit the menu display, press the **MENU** button.

External control device setup

- * Connect the RS-232C input jack to an external control device (such as a computer or an A/V control system) and control the Projector's functions externally.
- * When you connect a control(RS-232C) cable to this projector, use a control cable with a ferrite core attached. If you do not do this, this projector will not conform to mandatory CISPR22(EN55022) standards.

SET ID

- Use this function to specify projector ID number.

1 Press the **MENU** button and then use ▲ / ▼ button to select the  menu.

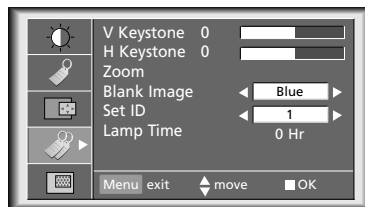

2 Press the **OK** (■) button and then use ▲ / ▼ button to select [Set ID] item.

3 Press the **VOLUME** (◀, ▶) button to adjust Set ID to select the desired projector ID number.

- The adjustment range of **Set ID** is 1~99.
- Only the projector with the specified ID number will operate from the remote control.
- To exit the menu display, press the **MENU** button.

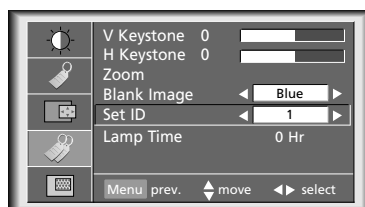



How to connect external control equipment

- Connect the serial port of the PC to the RS-232C jack on the projector back panel.
- RS-232C cable is not supplied with the projector.

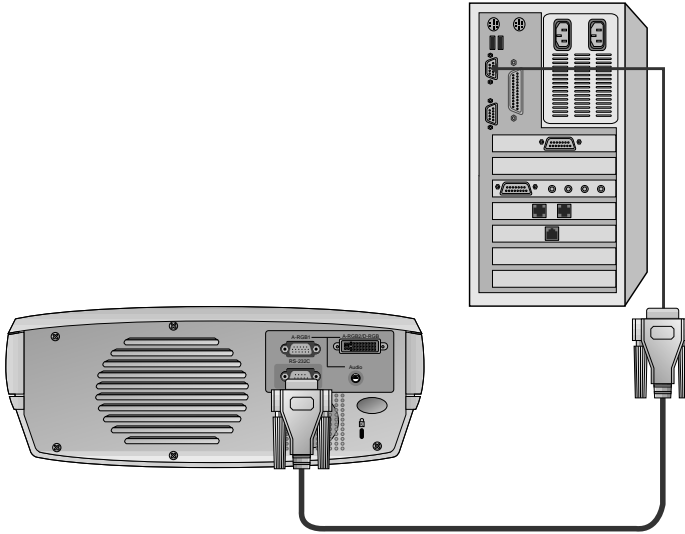

- Use the RS232C cable to control the projector externally (Refer to Fig.1).

<Fig.1, RS-232 Interface Cable>

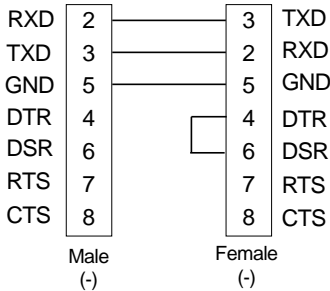

* 1, 9 Pin No Connection

Communication Parameter Setup

- Baud Rate : 19200 bps(UART)
- Data Length : 8 bit
- Parity : none
- Stop bit : 1 bit
- Flow Control : none
- Communication code : ASCII code

External control device setup

Command Reference List

	Command1	Command2-1	Command2-2	SET ID Data(Hexa)	Data(Hexa)
01. Power	k	0	0	00-63	00, 01
02. Input Select	k	0	1	00-63	00-05
03. Aspect Ratio	k	0	2	00-63	00-05
04. Screen Mute	k	0	3	00-63	00, 01
05. Sub Input Select	k	0	4	00-63	00-05
06. Contrast	k	3	0	00-63	00-64
07. Brightness	k	3	1	00-63	00-64
08. Color	k	3	2	00-63	00-64
09. Tint	k	3	3	00-63	00-64
10. Sharpness	k	3	4	00-63	00-64
11. Color R	k	3	6	00-63	00-64
12. Color G	k	3	7	00-63	00-64
13. Color B	k	3	8	00-63	00-64
14. Color Temp. R	k	3	9	00-63	00-64
15. Color Temp. G	k	3	a	00-63	00-64
16. Color Temp. B	k	3	b	00-63	00-64
17. Twin Picture Mode Select	k	4	1	00-63	00, 01, 02
18. Volume Mute	k	5	4	00-63	00, 01
19. Volume Control	k	5	0	00-63	00-64
20. OSD Lock mode	k	9	0	00-63	00, 01
21. Remote Control Lock mode	k	9	1	00-63	00, 01

□ Communication Protocol

1. Transmission

[Command1][Command2-1][Command2-2][Set ID][Data][Cr]

- * [Command 1] : To classify factory adjustment mode or user adjustment mode.(ASCII code, 1 Character)
- * [Command 2-1] : Group classification code to control set.(ASCII code, 1 Character)
→ Shortening Key Group : 0, Video Group : 3, Twin Picture Group : 4, Audio Group:5, Others : 9
- * [Command 2-2] : To control projector set.
- * [Set ID] : You can adjust the set ID to choose desired projector ID number in special menu. See previous page.
Adjustment range is 1 ~ 99. When selecting Set ID '0', every connected projector set is controlled.
- * [DATA] : To transmit command data. Transmit 2 character when organized ASCII code.
* Transmit 'FF' data to read status of command.
- * [Cr] : Carriage Return
ASCII code '0x0D'
- * [] : ASCII code character correspond to "Space Bar" which is in order to classify command set ID and Data.

[Command2-1][Command2-2][Set ID][OK][Data][X]

- * The Projector transmits ACK (acknowledgement) based on this format when receiving normal data. At this time, if the data is data read mode, it indicates present status data. If the data is data write mode, it returns the data of the PC computer.

2. Error Acknowledge

[Command2-1][Command2-2][Set ID][NG][Data][X]

- * The Projector transmits ACK (acknowledgement) based on this format when receiving abnormal data from non-viable functions or communication errors.

Data : [01] : illegal code(This command is not supported.)
 [02] : not support function(This function doesn't work.)
 [03] : wait more time(Try again a few minute later.)

01. Power (Command2-1:0, Command2-2:0)

→ To control Power On/Off of the Projector.

Transmission

[k] [0] [0] [Set ID] [] [Data] [Cr]

Data 00 : Power Off
01 : Power On

Ack

[0] [0] [] [Set ID] [] [OK] [Data] [X]

Data 00 : Power Off
01 : Power On

→ To show Power On/Off status.

Transmission

[k] [0] [0] [] [Set ID] [] [FF] [Cr]

Ack

[0] [0] [] [Set ID] [] [OK] [Data] [X]

Data 00 : Power Off
01 : Power On

* In like manner, if other functions transmit 'FF' data based on this format, Acknowledgement data feed back presents status about each function.

02. Input Select (Command2-1:0, Command2-2:1)

→ To select input source for the Set.

Transmission

[k] [0] [1] [] [Set ID] [] [Data] [Cr]

Data 00 : A-RGB1 01 : A-RGB2 02 : D-RGB
03 : Video 04 : S-Video 05 : Component

Ack

[0] [1] [] [Set ID] [] [OK] [Data] [X]

Data 00 : A-RGB1 01 : A-RGB2 02 : D-RGB
03 : Video 04 : S-Video 05 : Component

03. Aspect Ratio (Command2-1:0, Command2-2:2)

→ To adjust the screen format.

Transmission

[k] [0] [2] [] [Set ID] [] [Data] [Cr]

Data 00 : Wide Screen(16:9) 01 : Normal Screen(4:3)
02 : Zoom 1 03 : Zoom 2
04 : Zoom 3 05 : Zoom 4

Ack

[0] [2] [] [Set ID] [] [OK] [Data] [X]

Data 00 : Wide Screen(16:9) 01 : Normal Screen(4:3)
02 : Zoom 1 03 : Zoom 2
04 : Zoom 3 05 : Zoom 4

* Using the PC input, you select either 16:9 or 4:3 screen aspect ratio.

* Screen size function doesn't work with HD signal.

* Zoom1~Zoom4 mode works only with Video/S-Video/Component(480i(576i), 480p) input.

04. Screen Mute (Command2-1:0, Command2-2:3)

→ To select screen mute on/off.

Transmission

[k] [0] [3] [] [Set ID] [] [Data] [Cr]

Data 01 : Screen Mute On (Picture Off)
00 : Screen Mute Off (Picture On)

Ack

[0] [3] [] [Set ID] [] [OK] [Data] [X]

Data 01 : Screen Mute On (Picture Off)
00 : Screen Mute Off (Picture On)

05. Sub Input Select (Command2-1:0, Command2-2:4)

→ To select input source for sub picture.

Transmission

[k] [0] [4] [] [Set ID] [] [Data] [Cr]

Data 00 : A-RGB1 01 : A-RGB2 02 : D-RGB
03 : Video 04 : S-Video 05 : Component

Ack

[0] [4] [] [Set ID] [] [OK] [Data] [X]

Data 00 : A-RGB1 01 : A-RGB2 02 : D-RGB
03 : Video 04 : S-Video 05 : Component

External control device setup

06. Contrast (Command2-1:3, Command2-2:0)

→ To adjust screen contrast.

Transmission

[k] [3] [0] [] [Set ID] [] [Data] [Cr]

Data Min : 00 ~ Max : 64
* Refer to 'Real data mapping 1'.
* Always marks data value with Hexadecimal.
That is, marks with two-place Hexadecimal while writing and read data is also marked with Hexadecimal value.

Ack

[3] [0] [] [Set ID] [] [OK] [Data] [X]

Data Min : 00 ~ Max : 64

07. Brightness (Command2-1:3, Command2-2:1)

→ To adjust screen brightness.

Transmission

[k] [3] [1] [] [Set ID] [] [Data] [Cr]

Data Min : 00 ~ Max : 64
* Refer to 'Real data mapping 1'.
* Always marks data value with Hexadecimal.
That is, marks with two-place Hexadecimal while writing and read data is also marked with Hexadecimal value.

Ack

[3] [1] [] [Set ID] [] [OK] [Data] [X]

Data Min : 00 ~ Max : 64

08. Color (Command2-1:3, Command2-2:2)

→ To adjust the screen color.

Transmission

[k] [3] [2] [] [Set ID] [] [Data] [Cr]

Data Min : 00 ~ Max : 64
* Refer to 'Real data mapping 1'.
* Always marks data value with Hexadecimal.
That is, marks with two-place Hexadecimal while writing and read data is also marked with Hexadecimal value.

Ack

[3] [2] [] [Set ID] [] [OK] [Data] [X]

Data Min : 00 ~ Max : 64

9. Tint (Command2-1:3, Command2-2:3)

→ To adjust the screen tint.

Transmission

[k] [3] [3] [] [Set ID] [] [Data] [Cr]

Data Red : 00 ~ Green : 64
* Refer to 'Real data mapping2'.
* Always marks data value with Hexadecimal.
That is, marks with two-place Hexadecimal while writing and read data is also marked with Hexadecimal value.

Ack

[3] [3] [] [Set ID] [] [OK] [Data] [X]

Data Red : 00 ~ Green : 64

* Real data mapping 1	* Real data mapping 2
0 : Step 0	0 : Step -50
⋮	⋮
A : Step 10	32 : Step 0
⋮	⋮
F : Step 15	⋮
10 : Step 16	64 : Step 50
⋮	
64 : Step 100	

* This is a Hexadecimal number data.

10. Sharpness (Command2-1:3, Command2-2:4)

→ To adjust the screen sharpness.

Transmission

[k] [3] [4] [] [Set ID] [] [Data] [Cr]

Data Min : 00 ~ Max : 64
* Refer to 'Real data mapping 1'.
* Always marks data value with Hexadecimal.
That is, marks with two-place Hexadecimal while writing and read data is also marked with Hexadecimal value.

Ack

[3] [4] [] [Set ID] [] [OK] [Data] [X]

Data Min : 00 ~ Max : 64

11. Color R Adjustment (Command2-1:3, Command2-2:6)

→ To adjust red in color temperature.

Transmission

```
[k] [3] [6] [ ] [Set ID] [ ] [Data] [Cr]
```

Data Min : 00 ~ Max : 64

* Refer to 'Real data mapping 1'.

* Always marks data value with Hexadecimal.

That is, marks with two-place Hexadecimal while writing and read data is also marked with Hexadecimal value.

Ack

```
[3] [6] [ ] [Set ID] [ ] [OK] [Data] [X]
```

Data Min : 00 ~ Max : 64

12. Color G Adjustment (Command2-1:3, Command2-2:7)

→ To adjust green in color temperature.

Transmission

```
[k] [3] [7] [ ] [Set ID] [ ] [Data] [Cr]
```

Data Min : 00 ~ Max : 64

* Refer to 'Real data mapping 1'.

* Always marks data value with Hexadecimal.

That is, marks with two-place Hexadecimal while writing and read data is also marked with Hexadecimal value.

Ack

```
[3] [7] [ ] [Set ID] [ ] [OK] [Data] [X]
```

Data Min : 00 ~ Max : 64

13. Color B Adjustment (Command2-1:3, Command2-2:8)

→ To adjust blue in color temperature.

Transmission

```
[k] [3] [8] [ ] [Set ID] [ ] [Data] [Cr]
```

Data Min : 00 ~ Max : 64

* Refer to 'Real data mapping 1'.

* Always marks data value with Hexadecimal.

That is, marks with two-place Hexadecimal while writing and read data is also marked with Hexadecimal value.

Ack

```
[3] [8] [ ] [Set ID] [ ] [OK] [Data] [X]
```

Data Min : 00 ~ Max : 64

14. Color Temp. R (Command2-1:3, Command2-2:9)

→ Adjust the color temperature R of LCD part.

Transmission

```
[k] [3] [9] [ ] [Set ID] [ ] [Data] [Cr]
```

Data Min : 00 ~ Max : 64

* Refer to 'Real data mapping 1'.

* Always marks data value with Hexadecimal.

That is, marks with two-place Hexadecimal while writing and read data is also marked with Hexadecimal value.

Ack

```
[3] [9] [ ] [Set ID] [ ] [OK] [Data] [X]
```

Data Min : 00 ~ Max : 64

15. Color Temp. G (Command2-1:3, Command2-2:a)

→ Adjust the color temperature G of LCD part.

Transmission

```
[k] [3] [a] [ ] [Set ID] [ ] [Data] [Cr]
```

Data Min : 00 ~ Max : 64

* Refer to 'Real data mapping 1'.

* Always marks data value with Hexadecimal.

That is, marks with two-place Hexadecimal while writing and read data is also marked with Hexadecimal value.

Ack

```
[3] [a] [ ] [Set ID] [ ] [OK] [Data] [X]
```

Data Min : 00 ~ Max : 64

16. Color Temp. B (Command2-1:3, Command2-2:b)

→ Adjust the color temperature B of LCD part.

Transmission

```
[k] [3] [b] [ ] [Set ID] [ ] [Data] [Cr]
```

Data Min : 00 ~ Max : 64

* Refer to 'Real data mapping 1'.

* Always marks data value with Hexadecimal.

That is, marks with two-place Hexadecimal while writing and read data is also marked with Hexadecimal value.

Ack

```
[3] [b] [ ] [Set ID] [ ] [OK] [Data] [X]
```

Data Min : 00 ~ Max : 64

External control device setup

17. Twin Picture Mode Select (Command2-1:4, Command2-2:1)

→ To control the twin picture.

Transmission

[k] [4] [1] [] [Set ID] [] [Data] [Cr]

Data 00 : FULL 01 : TWIN 1 02 : TWIN 2

Ack

[4] [1] [] [Set ID] [] [OK] [Data] [X]

Data 00 : FULL 01 : TWIN 1 02 : TWIN 2

18. Volume Mute (Command2-1:5, Command2-2:4)

→ To control volume mute on/off.

Transmission

[k] [5] [4] [] [Set ID] [] [Data] [Cr]

Data 00 : Volume Mute On (Volume Off)
01 : Volume Mute Off (Volume On)

Ack

[5] [4] [] [Set ID] [] [OK] [Data] [X]

Data 00 : Volume Mute On (Volume Off)
01 : Volume Mute Off (Volume On)

19. Volume Control (Command2-1:5, Command2-2:0)

→ To adjust volume.

Transmission

[k] [5] [0] [] [Set ID] [] [Data] [Cr]

Data Min : 00 ~ Max : 64

* Refer to 'Real data mapping 1'.

* Always marks data value with Hexadecimal.

That is, marks with two-place Hexadecimal while writing and read data is also marked with Hexadecimal value.

Ack

[5] [0] [] [Set ID] [] [OK] [Data] [X]

Data Min : 00 ~ Max : 64

20. OSD Lock mode (Command2-1:9, Command2-2:0)

→ This function operates Local Keypad and Remote control Lock so that only Power button on Local Keypad works with "OSD Lock On".

Transmission

[k] [9] [0] [] [Set ID] [] [Data] [Cr]

Data 00 : OSD Lock Mode Off
01 : OSD Lock Mode On

Ack

[9] [0] [] [Set ID] [] [OK] [Data] [X]

Data 00 : OSD Lock Mode Off
01 : OSD Lock Mode On

21. Remote Control Lock mode (Command2-1:9, Command2-2:1)

→ To lock the front panel controls on the projector and remote control.

Transmission

[k] [9] [1] [] [Set ID] [] [Data] [Cr]

Data 00 : Remote Control Lock Off
01 : Remote Control Lock On

Ack

[9] [1] [] [Set ID] [] [OK] [Data] [X]

Data 00 : Remote Control Lock Off
01 : Remote Control Lock On

* If you're not use the remote control, set this mode.

Supported Monitor Display

- * The projector displays the best image quality at a resolution of 1280x720 pixels.
To display other resolution images, the projector compresses or expands it to 1280x720.
The following table lists the display formats supported by the projector.

Sources	Format	Vertical Freq. (Hz)	Horizontal Freq. (kHz)
VGA/EGA	640X350	70.090Hz	31.468kHz
	640X350	85.080Hz	37.861kHz
PC98 / VGA text	640X400	70.090Hz	31.468kHz
	640X400	85.080Hz	37.861kHz
	720X400	70.082Hz	31.469kHz
	720X400	85.039Hz	37.927kHz
VGA	640X480	59.940Hz	31.469kHz
	640X480	66.667Hz	35.00kHz
	640X480	72.800Hz	37.861kHz
	640X480	75.00Hz	37.500kHz
	640X480	85.008Hz	43.269kHz
SVGA	800X600	56.250Hz	35.156kHz
	800X600	60.317Hz	37.879kHz
	800X600	72.188Hz	48.077kHz
	800X600	75.00Hz	46.875kHz
	800X600	85.061Hz	53.674kHz
XGA	1024X768	60.004Hz	48.363kHz
	1024X768	70.069Hz	56.476kHz
	1024X768	75.029Hz	60.023kHz
SXGA	1152X864	60.053Hz	54.348kHz
	1280X960	60.00Hz	60.00kHz
	1280X1024	60.020Hz	63.981kHz
MAC	16"	832X624	74.550Hz
	19"	1024X768	60.004Hz
		1024X768	75.029Hz

- * If the projector does not support the input signal, "Out of Range" message appears on the screen.
- * The projector supports DDC1/2B type as Plug & Play function.(Auto recognition of PC monitor)
- * The Synchronization input form for horizontal and vertical frequencies are Separate, Composite and SOG.
- * According to PC, the optimum vertical frequency may not be displayed up to the optimum frequency of set in 'Registration information(Display registration information)'.(ex, The optimum vertical frequency may be displayed up to 75Hz or under in the resolution of 640X480 or 800X600.)

Maintenance

- * The projector needs little maintenance. You should keep the lens clean because any dirt or stains may appear on the screen. You will also need to clean the air filter attached at the bottom of the projector periodically because a clogged air filter prevents proper ventilation that is necessary to cool the projector and prevents it from overheating. If any parts need to be replaced, contact your dealer. When cleaning any part of the projector, always turn the power off and unplug the projector first.

Cleaning the lens

Clean the lens whenever you notice dirt or dust on the surface of it. Wipe the lens surface gently with an air spray or a soft, dry lint-free cloth.

To remove dirt or stains on the lens, moisten a soft cloth with water and a neutral detergent and wipe the lens surface gently.

Cleaning the Projector Case

To clean the projector case, first unplug the power cable. To remove dirt or dust, wipe the casing with a soft, dry, lint-free cloth. To remove stubborn dirt or stains, moisten a soft cloth with water and a neutral detergent and then wipe the casing.

Do not use alcohol, benzene, thinners or other chemical detergents as these can cause the casing to be warped.

Cleaning the Air Filter

The air filter, which is located at the bottom of the projector, should be cleaned after every 100 hours' use. If it is not cleaned periodically, it can become clogged with dust and prevent the projector from being ventilated properly. This may cause overheating and damage of the projector.

To clean the air filter :

1. Switch the projector off and unplug the power cable from the wall socket.
2. Stand the projector on it's side so that the handle can be at the top, and you can easily access the air filter.
3. Push the opening tip of the air filter cover and remove the cover.

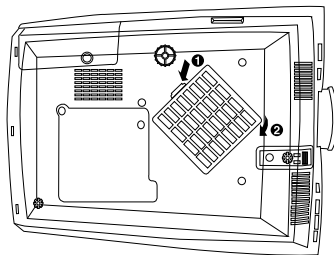

4. The air filter is inside the cover. To clean the filter, use a small vacuum cleaner designed for computers or other office equipment. If not, you may use a dry, lint-free cloth. If it is difficult to remove dirt or the filter is torn, contact your dealer or the service center to replace it.
5. Close the filter cover after cleaning.
6. Plug the power cable back into the wall socket.

Specifications

MODEL	RL-JA20
LCD panel size	0.87 inches
resolution	1280(Horizontal) x 720(Vertical)pixel
screen size	1.01~5.08m(40~200 inches)
remote control distance	12m
speaker system	3W
horizontal / vertical ratio	16:9(horizontal:vertical)
zoom ratio	1:1.3
Video compatibility	NTSC/PAL/SECAM/NTSC4.43/PAL-M/PAL-N
Power	AC 100 - 240V~50/60Hz
height	294.1mm(including front foot)
breadth	359.7mm
length	115.5mm(including lens)
weight	4.2kg

Operating Condition

temperature

In operation : 32~95°F(0°C~35°C)
 In storage and transit : -4~140°F(-20°C~60°C)

humidity

In operation : 0~ 80% relative humidity by dry hygrometer
 Not in operation : 0 ~ 90% relative humidity by dry hygrometer

Projection Lamp

lamp model

AJ-LA60

power consumption

210W

P/NO : 3828VA0360B@(373-026H)

