



ProSelecta

View :: Compare :: Select - www.ProSelecta.com

LG LCD PROJECTOR

**RL-JT10
OWNER'S MANUAL**

Please read this manual carefully before operating your set.

Retain it for future reference.

Record model number and serial number of the set.

See the label attached on the bottom of the set and quote this information to your dealer when you require service.

Model number :

Serial number :

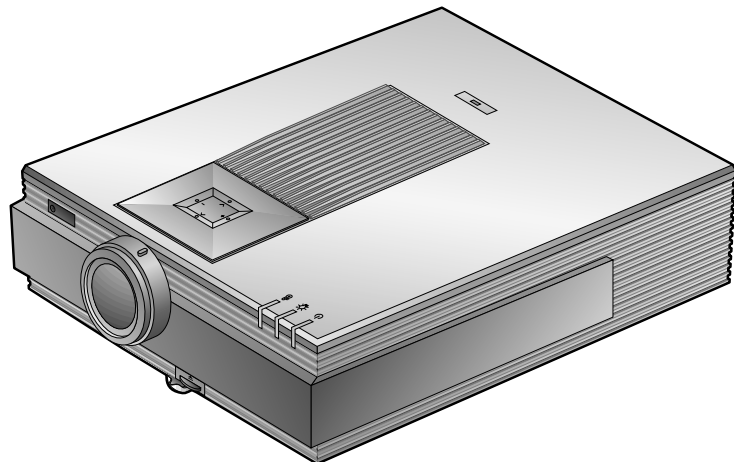

LCD PROJECTOR

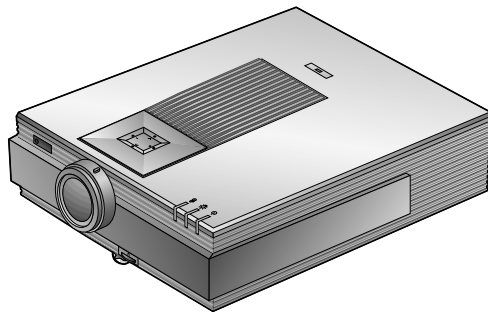

FCC NOTICE

- **A Class A digital device**

This equipment has been tested and found to comply with the limits for a Class A digital device, pursuant to Part 15 of the FCC Rules. These limits are designed to provide reasonable protection against harmful interference when the equipment is operated in a commercial environment. This equipment generates, uses, and can radiate radio frequency energy and, if not installed and used in accordance with the instruction manual, may cause harmful interference to radio communications. Operation of this equipment in a residential area is likely to cause harmful interference in which case the user will be required to correct the interference at his own expense.

CONTENTS

INDEX

INTRODUCTION	Safety Instructions	3
	Names of parts	11
INSTALLATION AND COMPOSITION	Installation Instructions	19
	Composition	21
	Turning on the Projector	23
	Turning off the Projector	24
	Operating the Projector	25
	Selecting source mode	26
CONNECTION	Connecting to a Desktop PC	27
	Connecting to a Notebook PC	28
	Connecting to a Macintosh Desktop PC	29
	Connecting to a Macintosh PowerBook	30
	Connecting to a Video Source	31
	Connecting to a DVD	32
	Connecting to a D-TV Settop Box	33
BASIC FUNCTIONS	Function checking	34
	Using Still function	35
SPECIAL FUNCTIONS	Selecting language	36
	Using Blank function	37
	Using Flip Horizontal / Vertical function	39
	Checking lamp time	41
POSITIONING	Using Resize function	42
	Adjusting screen display	43
TRACKING	Using Tracking function	45
VIDEO	Adjusting Video	47
RS-232C	External control device setup	48
INFORMATION	Supported Monitor Display	58
	Maintenance	59
	Memo	60
	Specifications	62

Before operating the unit, please read this manual carefully.

Safety Instructions

► Please take note of the safety instructions to prevent any potential accident or misuse of the projector.

► Safety Instructions are given in two forms as detailed below.

 **WARNING** The violation of this instruction may cause serious injuries and even death.

 **NOTES** The violation of this instruction may cause light injuries or damage to the projector.

► After reading this manual, keep it in the place that the user always can contact easily.

Indoor Installation-WARNING

Do not place the Projector in direct sunlight or near heat sources such as radiators, fires and stove etc.

- This may cause a fire hazard !

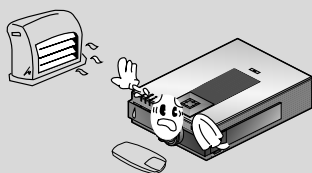

Do not place inflammable materials beside the projector

- This may cause a fire hazard !

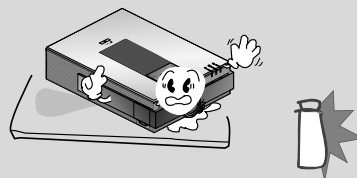

Do not make the children hang on or climb the installed projector.

- It may cause the display to fall, causing a injury or a death.

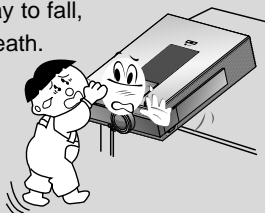

Indoor Installation-NOTES

Disconnect from the mains and remove all connections before moving.

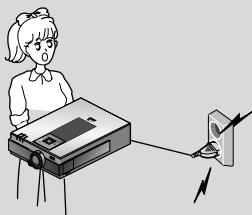

Do not place the projector close to sources of steam or oil such as a humidifier.

- This may create a fire hazard or an electric shock hazard !

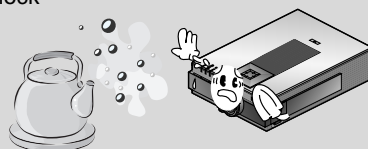



Indoor Installation-NOTES

Do not place the projector where it might be exposed to dust.

- This may cause a fire hazard !



When installing the projector on a table, be careful not to place it near the edge.

- This may cause the projector to fall causing serious injury to a child or adult and serious damage to the projector.
- **Only use a suitable stand.**



Only use the projector on a level and stable surface.

- It may become unstable and affect operation.

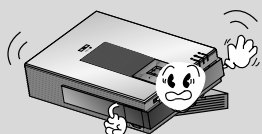

Ensure good ventilation around the projector. The distance between the projector and the wall should be more than 30cm.

- An excessive increase in its internal temperature may cause a fire hazard!



Don't clog the vents(air intake/exhaust) of the projector.

This would cause the internal temperature to increase and could cause a fire hazard!

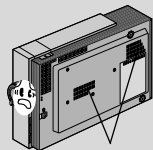

Air intake

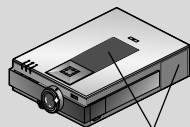

exhaust pipe

Do not place the projector directly on a carpet, rug or place where ventilation is restricted.

- This would cause its internal temperature to increase and might create a fire hazard !

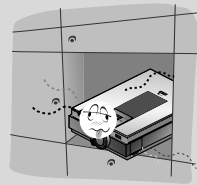

Outdoor Installation-WARNING

Do not use the projector in a damp place such as a bathroom where it is likely to get wet.

- This may cause a fire or an electric shock hazard !

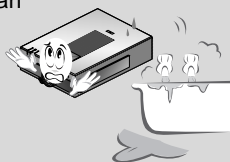

In case of using a receiver (VCR, Digital Set Top Box), bend antenna cable between inside and outside building to prevent rain from flowing in.

- This may cause water damaged inside the projector and could give an electric shock.

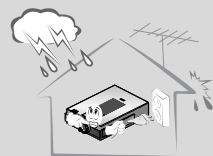

Safety Instructions

⚠ Outdoor Installation-NOTES

In case of using a receiver (VCR, Digital Set Top Box), do not place an antenna in the vicinity of power lines.

- This may cause an electric shock.

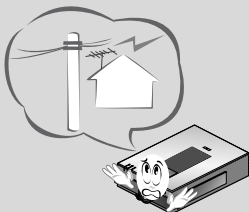

In case of using a receiver (VCR, Digital Set Top Box), contact your service center to construct an antenna because it needs skilled man.

- This may cause an electric shock.

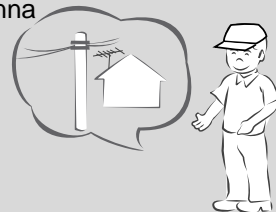

In case of using a receiver (VCR, Digital Set Top Box), there should be enough distance between an outside antenna and power lines to keep the former from touching the latter even when the antenna falls.

- This may cause an electric shock.

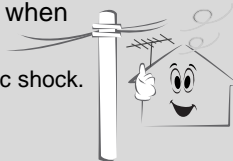

⚠ Power-WARNING

Earth wire should be connected.

- If the earth wire is not connected, there is possible a danger of electric shock caused by the current leakage.
- If grounding methods are not possible, a separate circuit breaker should be employed and installed by a qualified electrician.
- Do not connect ground to telephone wires, lightning rods or gas pipe.

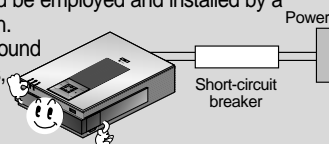

The mains plug should be inserted fully into the power outlet to avoid a fire hazard !

- This may cause a fire hazard !



Do not place heavy objects on the power cord

- This may cause a fire or an electric shock hazard !



Do not use too many plugs on the Mains multi-outlet.

- It may result in overheating of the outlet and causes a fire hazard !

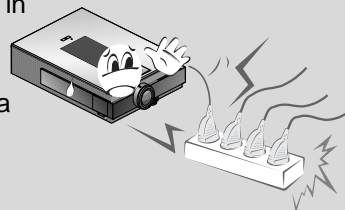

 **Power-NOTES**

Never touch the power plug with a wet hand
 - This may cause an electric shock hazard !



Hold the plug firmly when unplugging. If you pull the cord the cord may be damaged.
 - This may cause a fire hazard !



Prevent dust collecting on the power plug pins or outlet.
 - This may cause a fire hazard !

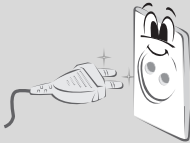

Do not plug when the power cord or the plug is damaged or the connecting part of the power outlet is loose.
 - This may cause a fire or an electric shock hazard !



Ensure the power cord does not come into contact with sharp or hot objects such as a heater.
 - This may cause a fire or an electric shock hazard !

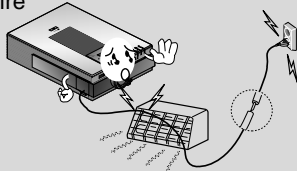

Place the projector where people will not trip or tread on the power lead.

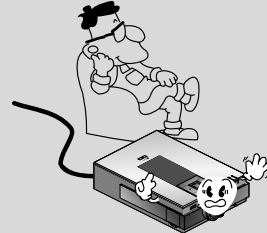

Do not turn the projector On/Off with plugging-in or unplugging the power plug to the wall outlet. (Do not use the power plug for switch.)
 - It may cause mechanical failure or could give an electric shock.

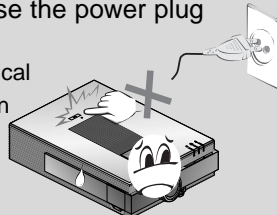

Safety Instructions

⚠ Using-WARNING

Do not place anything containing liquid on top of the projector such as flowerpot, cup, cosmetics or candle.

- This may cause a fire hazard !



In case of impact shock or damage to the projector switch it off and unplug it from the mains outlet and contact your service center.

- This may cause a fire or an electric shock hazard !

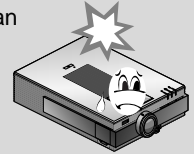

Do not allow any objects to fall into the projector.

- This may cause an electric shock hazard !

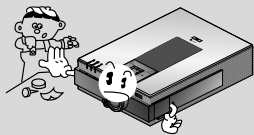

If water is spilled into the projector unplug it from the mains supply outlet immediately and consult your Service Agent.

- This may cause an electric shock hazard !



Dispose of used batteries carefully and safely.

- In the case of a battery being swallowed by a child please consult a doctor immediately.



In the event that an image does not appear on the screen please switch it off and unplug it from the mains supply and contact your Service Agent.

- This may cause a fire or an electric shock hazard !

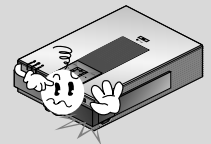

Do not use the projector in a moving vehicle.

- This may cause an accident.

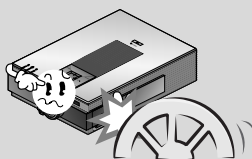

Do not remove any covers (except lens cover). High risk of Electric Shock!



⚠ Using-WARNING

Don't look directly onto the lens when the projector is in use. Eye damage may occur!

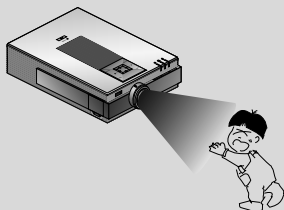

Don't look at laser beam directly as it can cause eye damage!

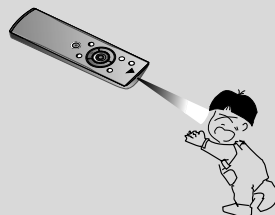

Do not touch metal parts during or soon after operation since the vents and lamp cover will remain very hot!

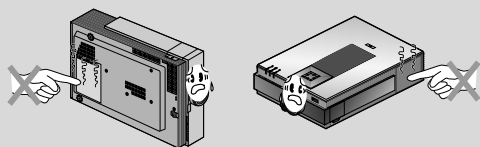

Never touch the wall outlet when there is leakage of gas, open the windows and ventilate.

- It can cause a fire or a burn by a spark.

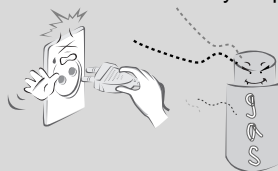

⚠ Using-NOTES

Do not drop the projector or allow impact shock.

- This may cause mechanical failure or personal injury!



Do not place heavy objects on top of projector.

- This may cause mechanical failure or personal injury!



Take care not to cause impact to the lens particularly when moving the projector.

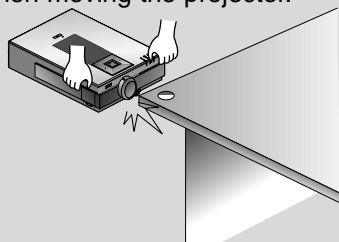

Do not stand the projector vertically or use the projector in an inverted position.

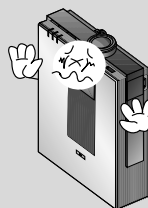

Safety Instructions

⚠ Using-NOTES

Do not touch the lens of the projector. It is delicate and easily damaged.

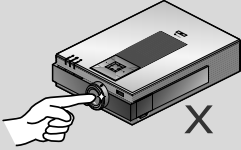

Do not use any sharp tools on the projector as this will damage the casing.

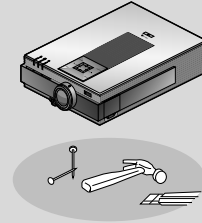

Do not position the AV box near the vents of the projector.

This may cause mechanical failure or a fire hazard!

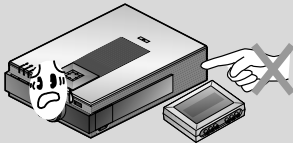

Do not place objects on top of the projector.

The top and bottom of the projector will get hot! This may cause mechanical failure or a fire hazard!

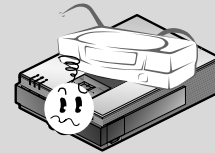

⚠ Cleaning-WARNING

Do not use water while cleaning the projector

- This may cause damage to the projector or an electric shock hazard.

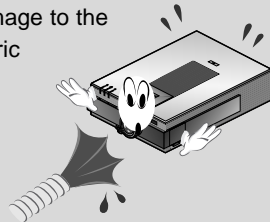

In the unlikely event of smoke or a strange smell from the projector, switch it off, unplug it from the wall outlet and contact your dealer or service centre.

- This may cause a fire or an electric shock hazard!

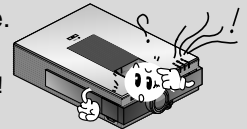

Use an air spray or soft cloth that is moist with a neutral detergent and water for removing dust or stains on the projection lens.

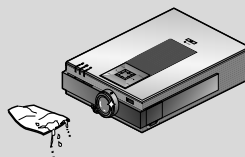

⚠ Cleaning-NOTES

Unplug this product from the wall outlet before cleaning. Do not use liquid cleaners or aerosol cleaners.

- This may cause damage to the Projector or cause an electric shock hazard !

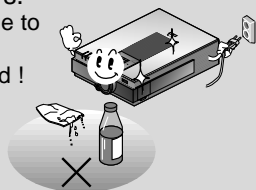

Contact the Service Center once a year to clean the internal parts of the projector.

- Accumulated dust can cause mechanical failure.

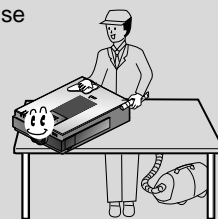

⚠ Others-WARNING

Do not attempt to service the projector yourself. Contact your dealer or service centre.

- This may cause damage to the projector and could give an electric Shock as well as invalidating the warranty !

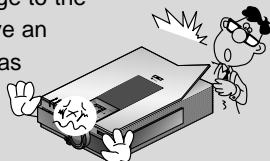

In case of using a receiver (VCR, Digital Set Top Box), in the event of a lightning or thunder storm unplug the projector and aerial from the wall outlet.

- This will prevent damage to the projector and possible electric shock.

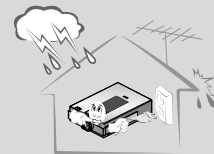

⚠ Others-NOTES

Be sure to unplug if the projector is not to be used for a long period.

Accumulated dust may cause a fire hazard!

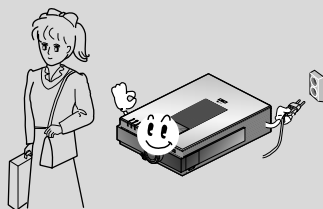

Refer lamp servicing to qualified service personnel.

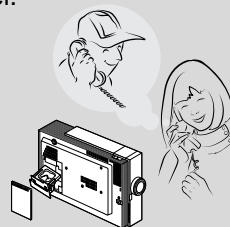

Do not mix new batteries with old batteries.

- It can cause a battery explosion, a fire by leakage or could give an electric shock.

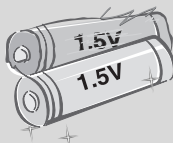

Only use the specified type of battery.

- This could cause damage to the remote control.

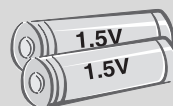

Names of parts

Main Body

- * The LCD projector is manufactured using high-precision technology. You may, however, see a few tiny black or coloured dots that continuously appear on the projector image. This is a normal result of the manufacturing process and does not indicate a malfunction.
- * If you store the projector in a cold place, to avoid condensation forming internally, wait for one hour before using the projector after placing in a warm room.

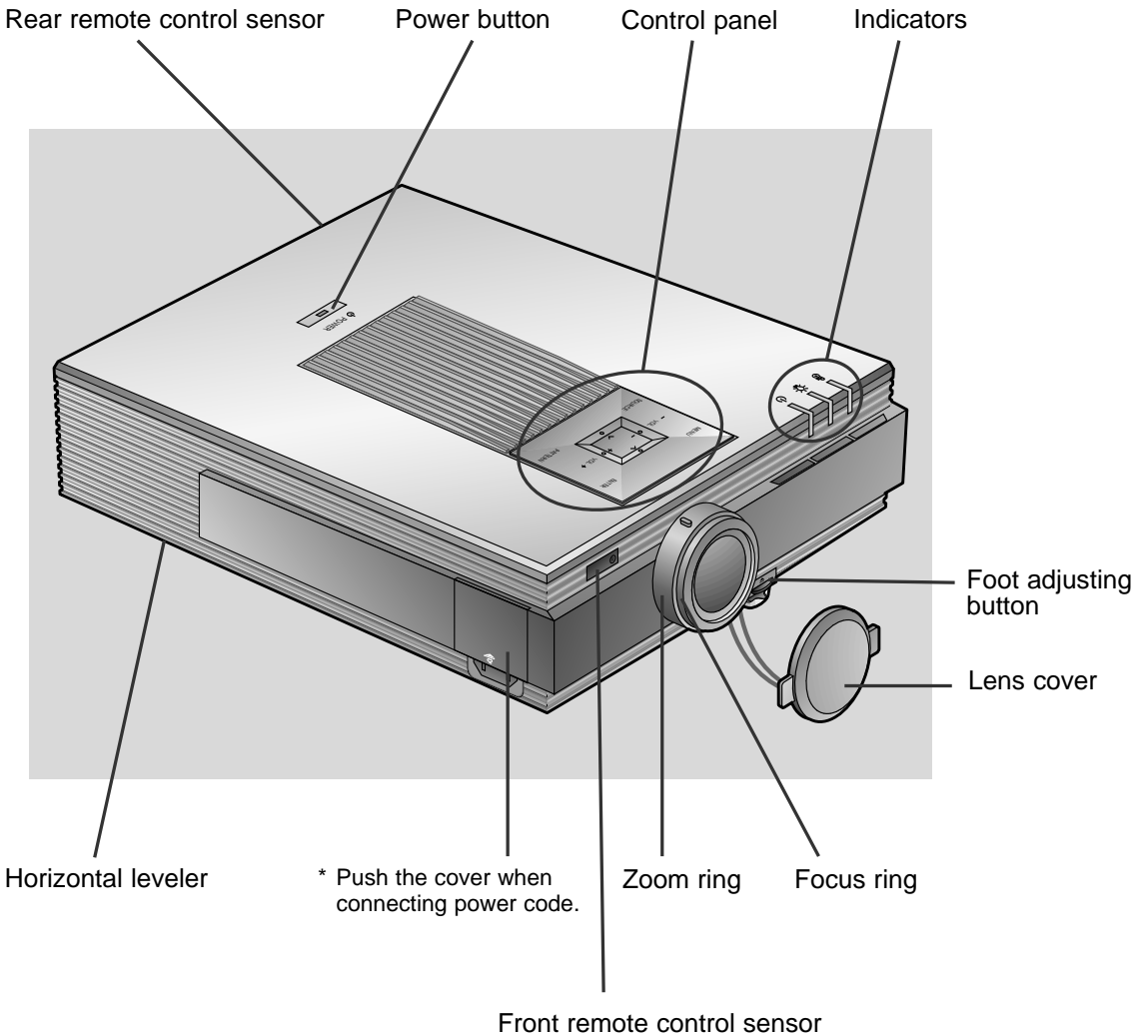

Rear Connections

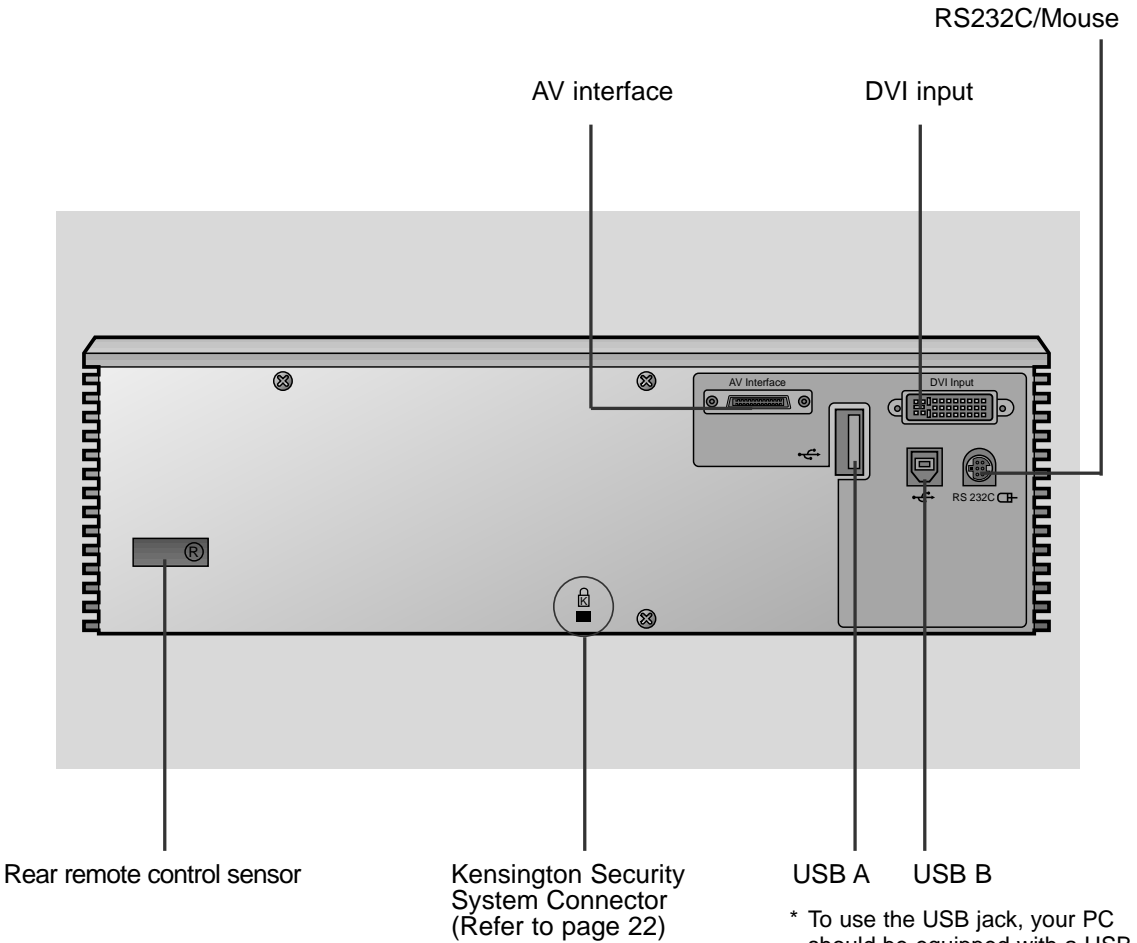

* To use the USB jack, your PC should be equipped with a USB jack.

- Connect a mouse to the USB A jack.
- Connect USB jack of PC to the USB B jack of the projector with USB cable supplied.

Control Panel

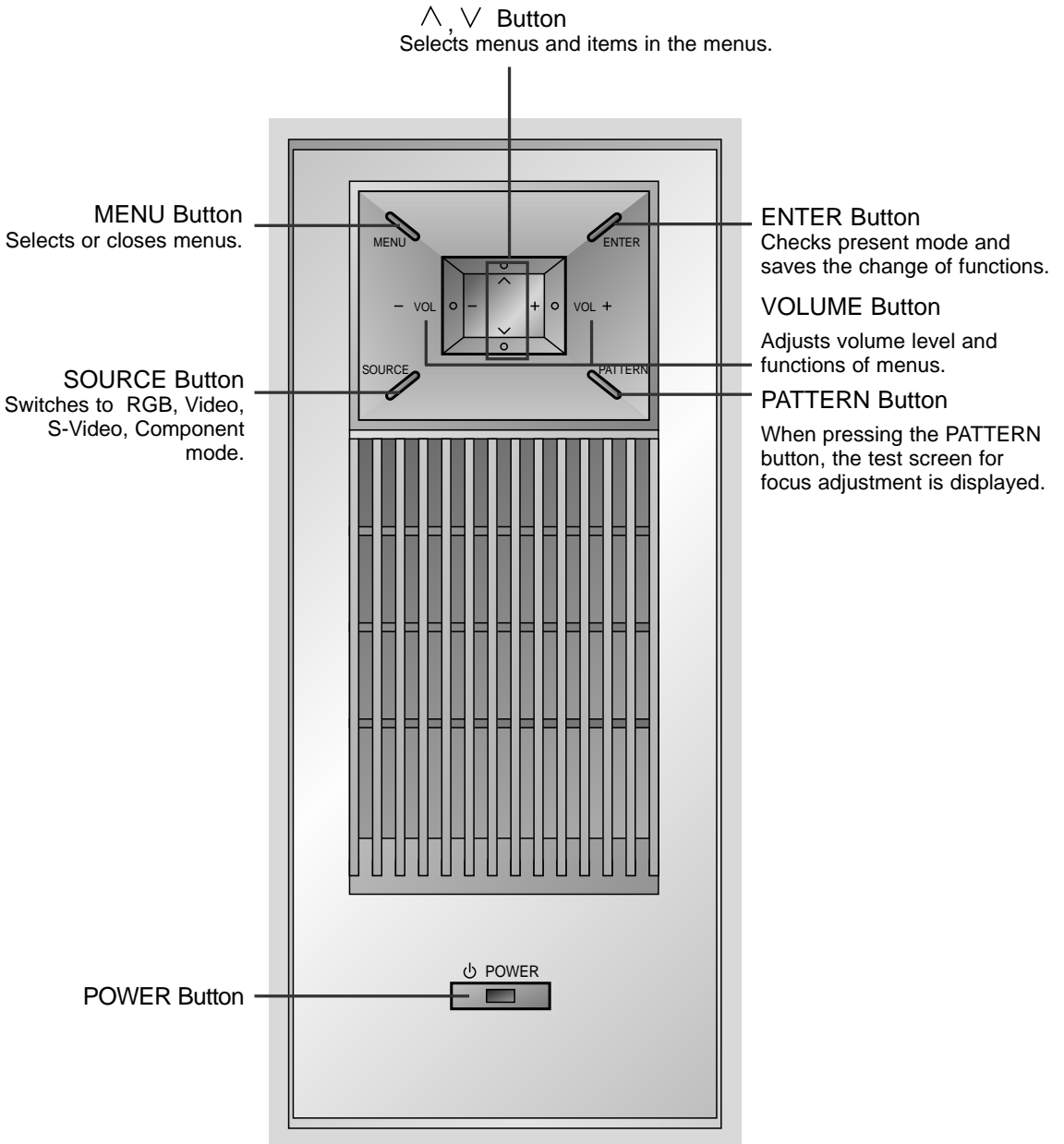

AV box front Panel

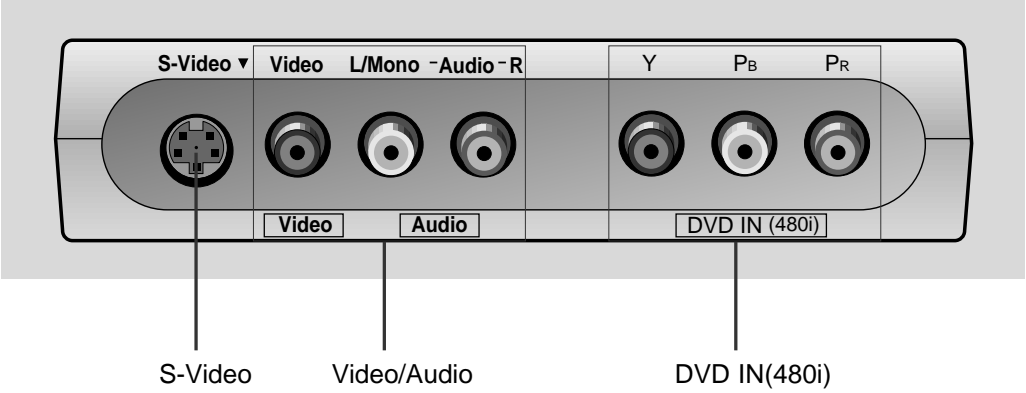

AV box back Panel

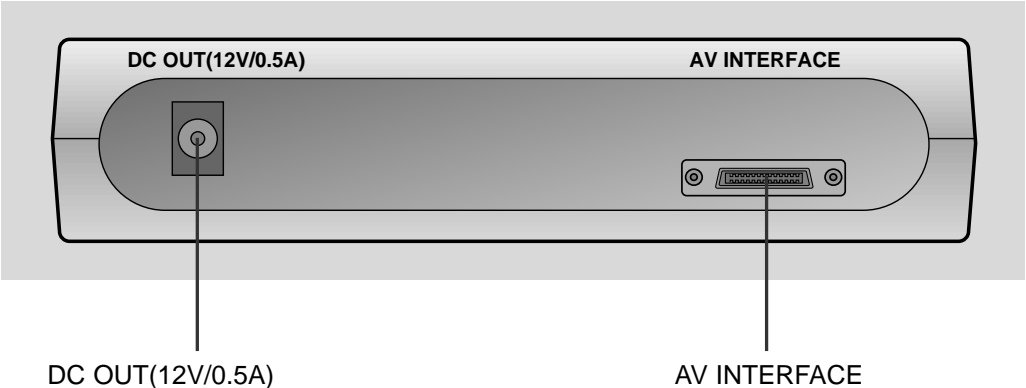

DC OUT(12V/0.5A)
 * Use this jack when connecting the wireless receiver to the projector.

Remote Control

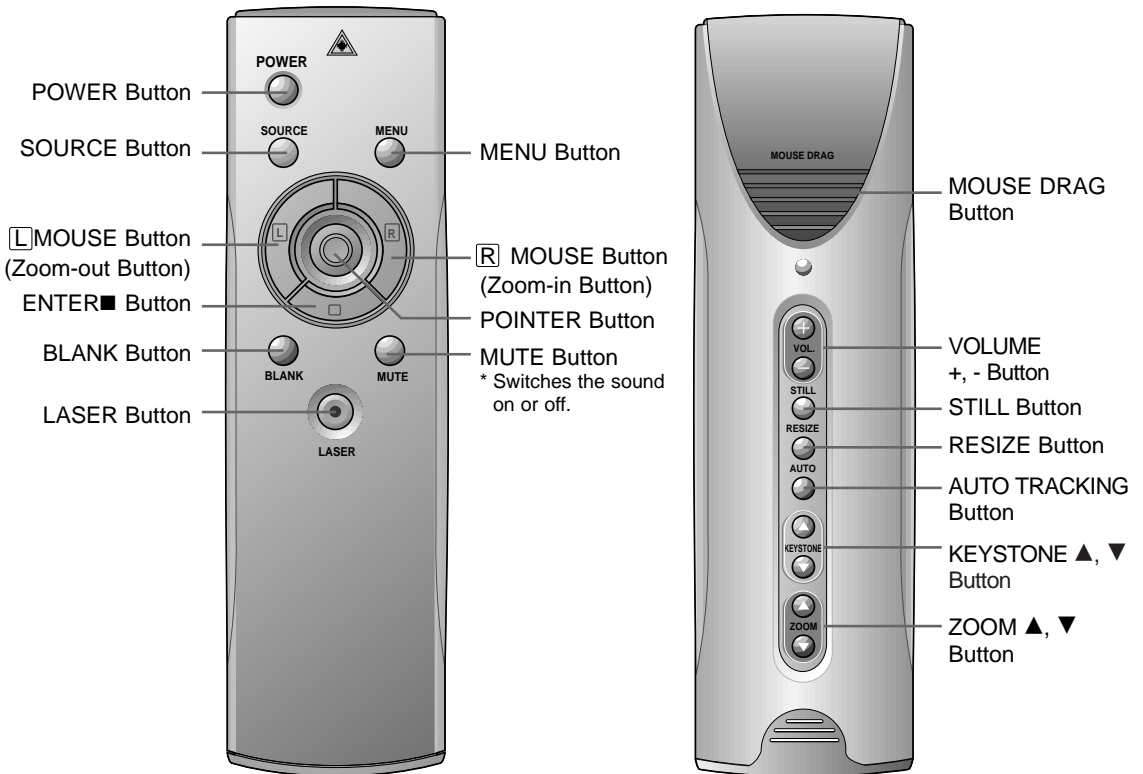

Inserting the batteries

1 Slide the battery cover in the direction of the arrow to remove.

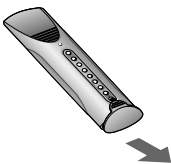



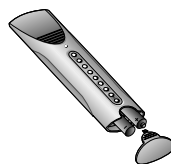

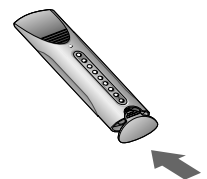

2 Insert the batteries with correct polarity.



3 Replace the battery compartment cover to the arrow direction.



Functions on the Remote Control

Button	Function
POWER Button	Selects ON/OFF of power.
SOURCE Button	Switches to RGB, Video, S-Video, Component mode.
MENU Button	Displays or hides the menu.
 MOUSE Button (Zoom-out Button)	* Corresponds to the Left - Click of PC Mouse. * Downsizes the screen on the zoom function.
 MOUSE Button (Zoom-in Button)	* Corresponds to the Right - Click of PC Mouse. * Enlarges the screen size on zoom function.
POINTER Button	* After selecting menus, controls selecting and adjusting functions with the direction of up, down, left, right. * Moves the screen with the direction of up, down, left, right on zoom function. * Moves and releases the selected icon on PC screen.
MOUSE DRAG Button	Uses to select and drag an icon in PC mode.
ENTER  Button	Checks the present mode and saves the change of functions.
ZOOM  ,  Button	Refer to page 44.
KEYSTONE  ,  Button	Refer to page 43.
RESIZE Button	Refer to page 42.
AUTO TRACKING Button	Refer to page 45~46.
BLANK Button	Refer to page 37~38.
STILL Button	Refer to page 35.
MUTE Button	Cuts off audio.
VOL.(+, -) Button	Adjusts volume level.
LASER Button	Produces a bright red laser pointer on the screen for the purpose of indication. (Don't look at laser beam directly as it can cause eye damage!)

Projector Status Indicators

* Temperature indicator, lamp Indicator, operation indicator at the top front of the projector indicate the operating status of the projector.

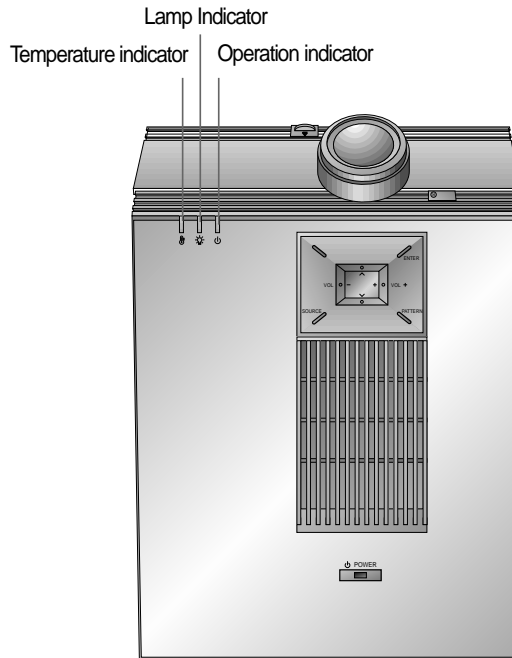

Operation Indicator	Orange	Standby.
	Green(flashing)	Lamp cooling until the lamp turn on(Refer to P.23)
	Green	On operation.(Turn on the lamp)
	Red	Projector lamp is cooling as power out(2 minutes)
	Off	Power off.
Lamp Indicator	Red	Projection lamp is reaching the end of its life and needs to be replaced with a new lamp.(over 1900 hours) "Replace the Lamp"
	Red(flashing)	The projector has trouble in the lamp or around it. Contact the service center.
	Green(flashing)	The lamp cover is not closed.
Temperature Indicator	Orange	Warning about "high temperature". Turn the power of projector off and check the ventilator. "Temperature is Too High"
	Red	The projector is turned off due to its continual high temperature.
	Red (flashing)	Power has turned off due to a problem with the internal cooling fan. Contact your service center.

" " is the warning message on screen.

Accessories



Remote Control

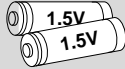

Batteries 2 (size AA)

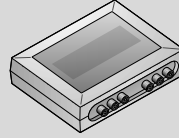

AV Box



Power Cord



Audio/Video Cable



AV Box cable



DVI to VGA Cable

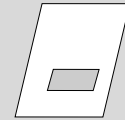

Operating guide



RS-232C cable



DVI cable



USB Cable

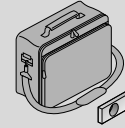

Portable Bag
/Sponge for lens protection

Mouse Connecting Cables



PS/2 Mouse Cable
(IBM PC or Compatible)



MAC Serial Mouse Cable

Optional Extras

- * Contact your dealer for buying these items.
- * When applying a ceiling installer, use only the ceiling installer for LCD projector.
- * Contact your dealer for replacing a new lamp.

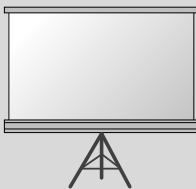

Projection Screen



S-Video Cable

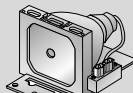

Lamp

Ceiling installer for LCD projector

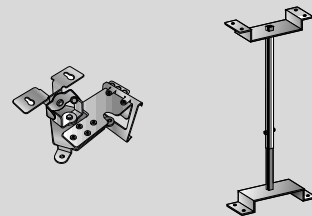

Installation Instructions

* Don't place the projector in the following conditions. It may cause malfunction or product damage.

Provide proper ventilation for this projector.

- The projector is equipped with ventilation holes(intake) on the bottom and ventilation holes(exhaust) on the front. do not block or place anything near these holes, or internal heat build-up may occur, causing picture degradation or damage to the projector.
- Do not place the projector on a carpet, rug or other similar surface. It may prevent adequate ventilation to the projector bottom. This product should be mounted securely to a suitable bracket or stand.

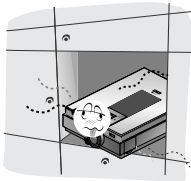

- Avoid impact to the projector. Do not spill liquid of any kind into the projector.

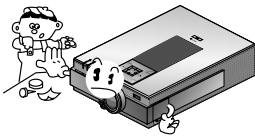

- Leave an adequate distance(30cm or more) around the projector.

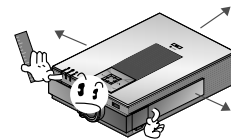

Use and keep this projector in suitable temperature and humidity conditions.

- Install this projector only in a location where adequate temperature and humidity are controlled. (refer p.62)

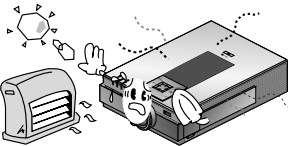

Don't place the projector where it can be covered with dust.

- This may cause overheating of the projector. Clean the Air filter periodically.

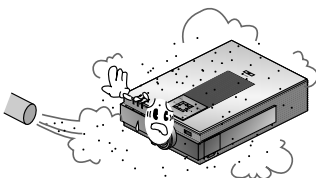

- Do not obstruct the vents of the projector. It may cause overheating.

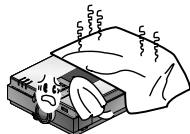

- Turn off the projector or switch the projector to standby mode to connect the AV box.

- The LCD projector is manufactured using high-precision technology. You may, however, see tiny black or coloured dots continuously appear on the LCD projector image. This is a normal result of the manufacturing process and does not indicate a malfunction.

- This product should be used adequate length bolt(within 5mm) when installing it. The bolt not included with the projector.

- When applying a ceiling installer, use only the fixing bolt and ceiling installer for LCD projector. Contact your dealer for purchase or installation.

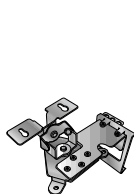

AJ-CA30

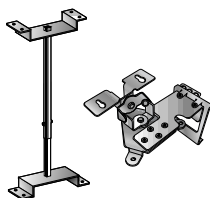

AJ-CA31

- To receive D-TV programmes, it is necessary to purchase a D-TV receiver (Set-Top Box) and connect it to the projector.

- If there is no input signal, the Menu will not display on screen.

Composition

Basic Operation of the Projector

1. Place the projector on a sturdy and horizontal surface with the PC or AV source.
2. Place the projector the correct distance from the screen. The distance between the projector and the screen determines the actual size of the image.
3. Turn the projector so that the lens can be at a right angle to the screen. If the projector is not at a right angle, the screen image will be crooked. At this time perform keystone function.(Refer to page 43.)
4. Connect the cables of the projector to a wall power socket and other connected sources.

projection distance based on the picture format

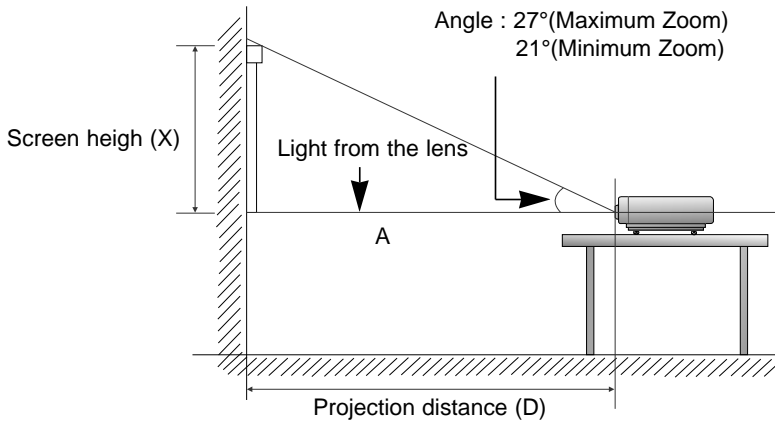

* A: Match the screen height(X) bottom with light from the lens.

4:3 picture format										mm
screen size	40"	50"	60"	80"	100"	110"	120"	150"	180"	200"
screen height (X)	609	762	917	1219	1524	1679	1828	2286	2743	3048
The shortest distance (D)	1200	1500	1800	2400	3000	3300	3600	4500	5400	6000
The longest distance (D)	1560	1950	2340	3120	3900	4290	4680	5850	7020	7800

* The longest distance/the shortest distance show status what adjusted by zoom function. At this time, turn the zoom ring to adjust it.

Using Kensington Security System

- The projector has Kensington Security System Connector on the back panel. Connect the Kensington Security system cable as below.
- For the detailed installation and use of the Kensington Security System, refer to the user's guide attached to the Kensington Security System set.
For further information, contact <http://www.kensington.com>, the internet homepage of the Kensington company that deals with expensive electronic equipment such as notebook PCs or LCD projectors.
- Kensington Security System is an optional item.

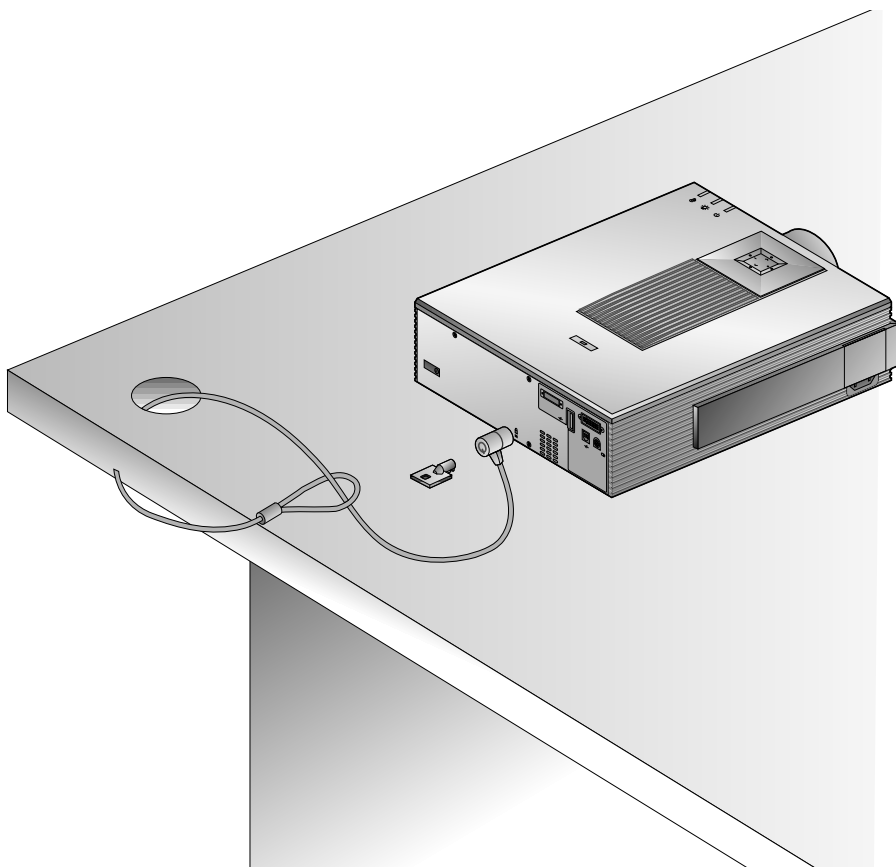

Turning on the Projector

1 Connect power cord correctly.

2 Remove the lens cover of the projector.

3 Press the **POWER** button on the remote control or top cover.(Green operation indicator flashes during cooling of the lamp.)

- It will take about 1 minute to display the picture after power on because the projector lamp has to warm up.
 - An image will appear after the operation indicator light up(Green).
 - Select the source mode with the **SOURCE** button.
 - Leave the projector plugged in for at least 2 minutes after switching off the projector, as this will allow the lamp cooling to continue which will help to preserve the lamp life.
-

4 Adjust volume level.

- If you press **VOLUME +** button, sound and volume level number are increased.
- If you press **VOLUME -** button, sound and volume level number are decreased.

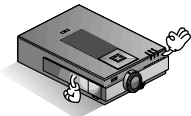
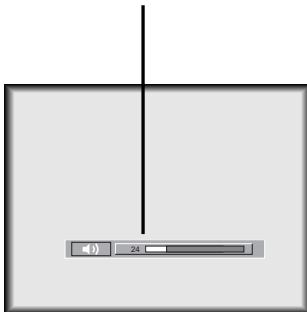

* Don't turn main power off and don't unplug the power cord while the ventilation fan(inlet/outlet) is working.

Turning off the Projector

- 1 Press the **POWER** button on the top cover or remote control.

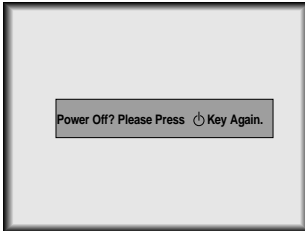

-
- 2 Press the **POWER** button on the top cover or remote control again to cut off the power.

-
- 3 If operation indicator is light up(red), leave the power cord plugged into the outlet. Do not pull out from the outlet until operation indicator is light up(orange).
 - If operation indicator is light up(red), the power button on the top cover or remote control may not operate.

Operating the Projector

Focus and Position of the Screen Image

When an image appears on the screen, check if it is in focus and fits well to the screen.

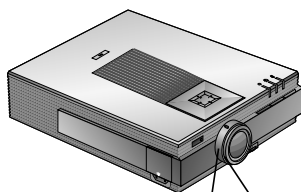

Zoom ring Focus ring

- To adjust the focus of the image, rotate the focus ring which is the outer ring on the lens.
- To adjust the size of the image, rotate the zoom ring which is the inner ring on the lens.

To raise or lower the image on the screen, extend or retract the foot at the bottom of the projector by pushing foot adjuster button as below.

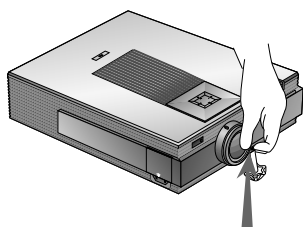

1. Stand behind the projector and lift the foot adjuster levers while you support the front of the projector.
2. While pressing the foot adjuster button, raise or lower the projector to place the screen image in the proper position.
3. Release the button to lock the foot in its new position.
4. To fine-tune the height of the projector, rotate the front foot to raise or lower it.
After raising the front foot, do not press down on the projector.

If the projector is installed on a place that is not stable or horizontal, the projected screen shape will be distorted.

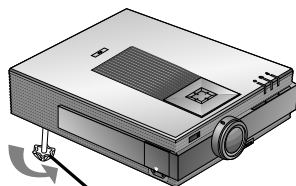

Horizontal leveler

- Adjust the screen shape to be horizontal and rectangular with horizontal leveler as above.
- Avoid impact or extra weight on top of the projector as it may cause the feet to alter position or damage them.

Selecting source mode

1 Press the **SOURCE** button

2 Each press of the **SOURCE** button changes the display as below.

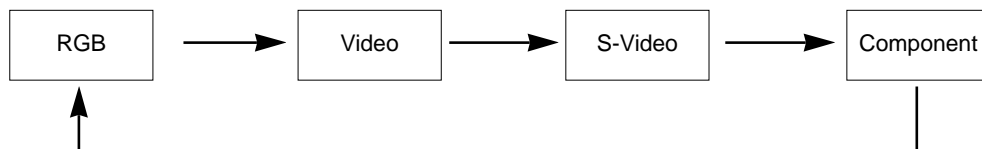

Connecting to a Desktop PC

- * You can connect the projector to a computer of VGA, SVGA, XGA and SXGA output.
- * You can use resize function for VGA, SVGA output.
- * Refer to page 58 for the supported pc graphic card displays of the projector.

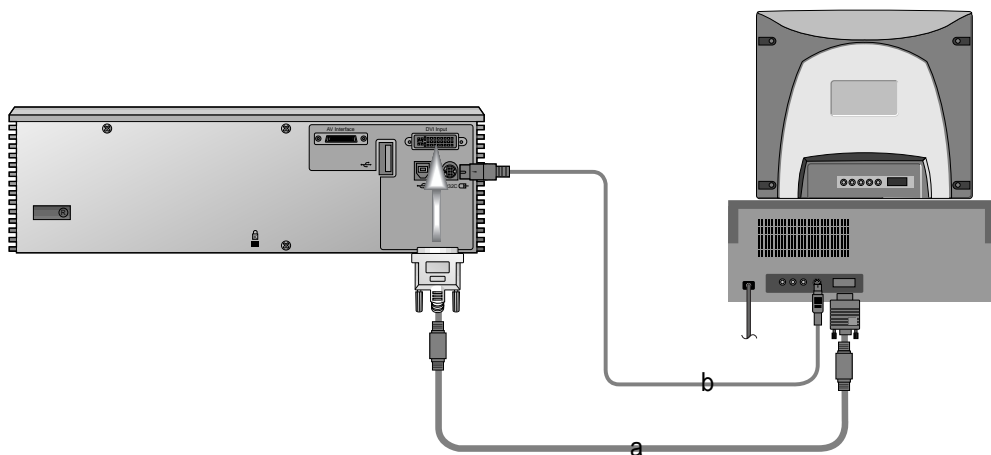

< How to connect >

- Connect either end of the DVI to VGA cable to **DVI input** of the projector.
* If the PC has DVI output, use DVI cable.
- Connect the a PS/2 mouse(for IBM PC or compatible) cable(6 pin) to the **RS232C**  of the projector.

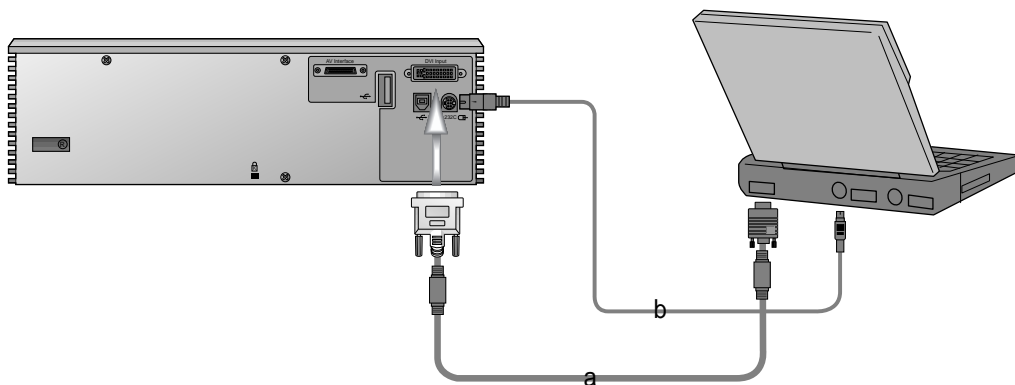

< How to connect >

- a. Connect either end of the DVI to VGA cable to **DVI input** of the projector.
 - * If you set your computer, such as a notebook type IBM PC/AT compatible, to output the signal to both the display of your computer and the external monitor, the picture of the external monitor may not appear properly. IN such cases, set the output mode of your computer to output the signal only to the external monitor. For details, refer to the operating instructions supplied with your computer.
 - * If the PC has DVI output, use DVI cable.

- b. Connect the PS/2 mouse(for IBM PC or compatible) cable(6 pin) to the **RS232C**  of the projector.

Connecting to a Macintosh Desktop PC

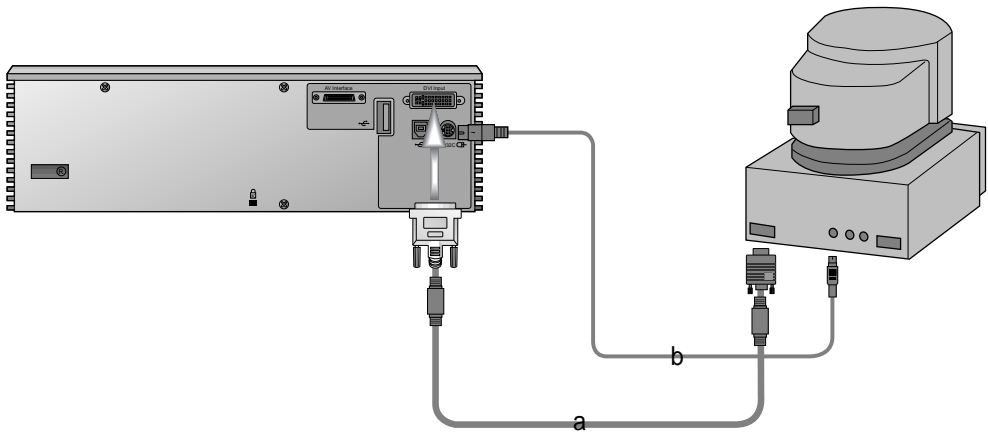

< How to connect >

- a. Connect either end of the DVI to VGA cable to **DVI input** of the projector.
- b. Connect the mouse cable(4 pin) from the Macintosh mouse port to the **RS232C** of the projector.

Connecting to a Macintosh PowerBook

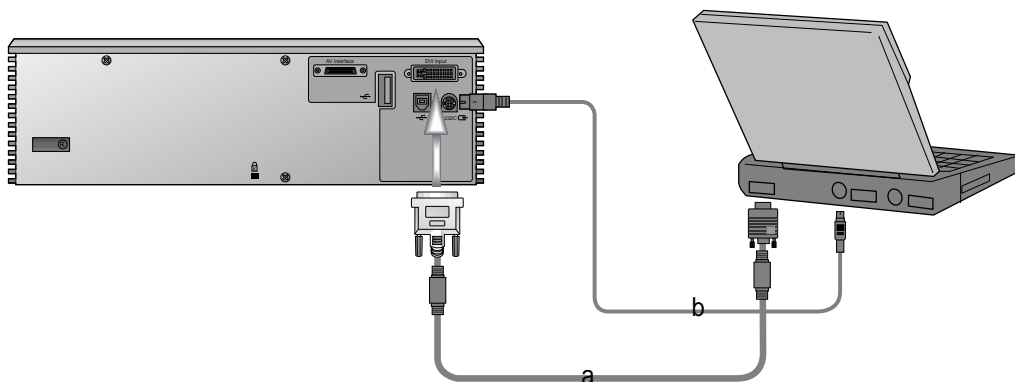

< How to connect >

- a. Connect either end of the DVI to VGA cable to **DVI input** of the projector.
- b. Connect the mouse cable from the Macintosh PowerBook mouse port to the **RS232C** of the projector.

Connecting to a Video Source

* In AV input mode, if the auto video system recognition fails to detect a correct video system type, please press the **AUTO TRACKING** button on the remote.

* You can connect a VTR, a camcorder, a LDP or any other compatible video image source to the projector.

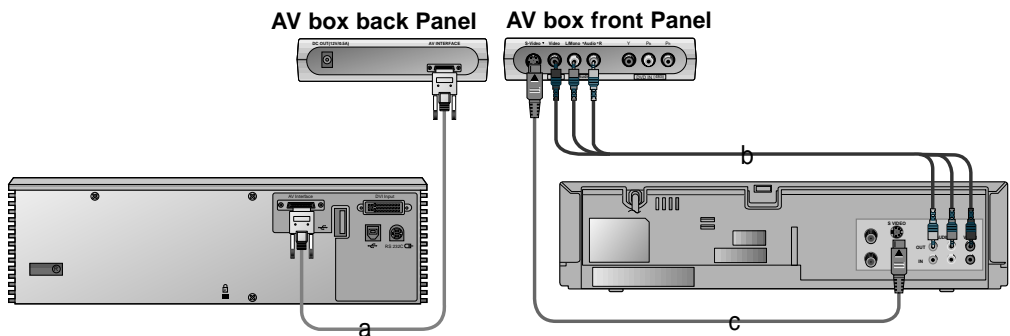

< How to connect 1 >

- Connect the AV interface jack of the projector to the AV interface jack of the AV box using the AV box cable.
- Connect the AV inputs of the AV box to the outputs of an A/V source using A/V cable. The video cable is yellow and the left audio is white and right audio is red.

< How to connect 2 >

- Connect the S-Video input of the AV box to the S-Video output of an A/V source with an S-Video cable.
* You can enjoy a better picture quality when connecting S-Video equipment to the projector.

Connecting to a DVD

* The outputs(Y, P_B, P_R) of the DVD might be labelled as Y, P_b, P_r / Y, B-Y, R-Y / Y, C_b, C_r according to the equipments.

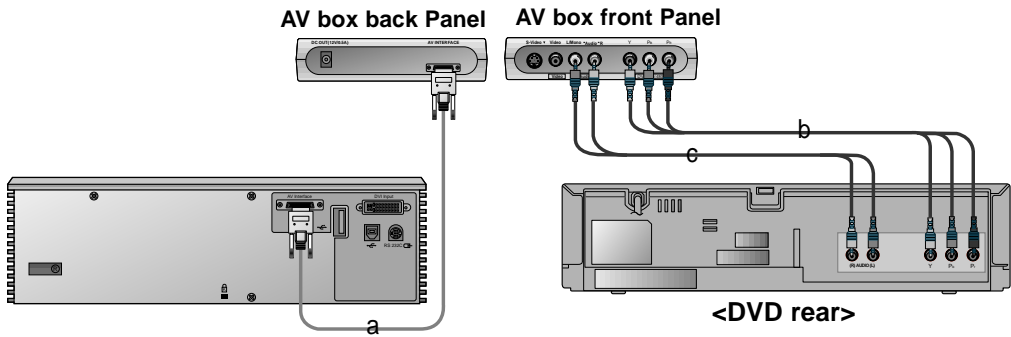

< How to connect >

- a. Connect the AV interface jack of the projector to the AV interface jack of the AV box using the AV box cable.
- b. Connect the **DVD IN(480i)** ports (Y, P_B, P_R) of the AV box to the Video output ports (Y, P_B, P_R) of the DVD.
- c. Connect the Audio output ports (R, L) of the AV box to the Audio output ports (R, L) of the DVD.

Connecting to a D-TV Settop Box

- * To receive D-TV programmes, it is necessary to purchase a D-TV receiver (Set-Top Box) and connect it to the projector.
- * Please refer to the owner's manual of the D-TV Set-Top Box for the connection between LCD projector and D-TV Set-Top Box.
- * Use a D-TV receiver with DTV 720p/1080i mode.

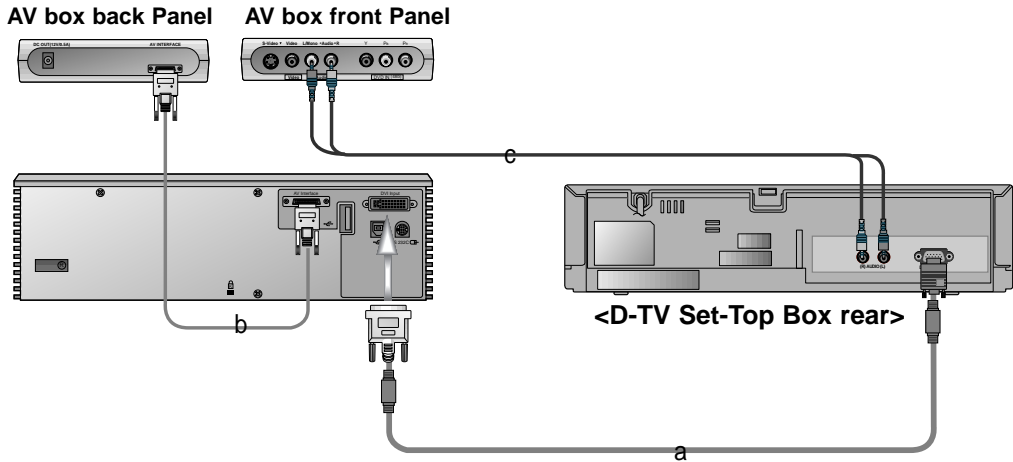

< How to connect >

- Connect either end of the DVI to VGA cable to **DVI input** of the projector.
- Connect the AV interface jack of the projector to the AV interface jack of the AV box using the AV box cable.
- Connect the Audio inputs (**R, L/Mono**) of the AV Box to the Audio output (**R, L**) of the D-TV Settop Box.

Function checking

- * If there is no input signal, the Menu will not display on screen.
- * This operating guide explains operation of RGB (PC) mode mainly.

1 Press the **MENU** button.

2 Move the **POINTER** button up or down to select a menu and press the **ENTER**(**■**) button. Each time you press the button you can see menus as below.

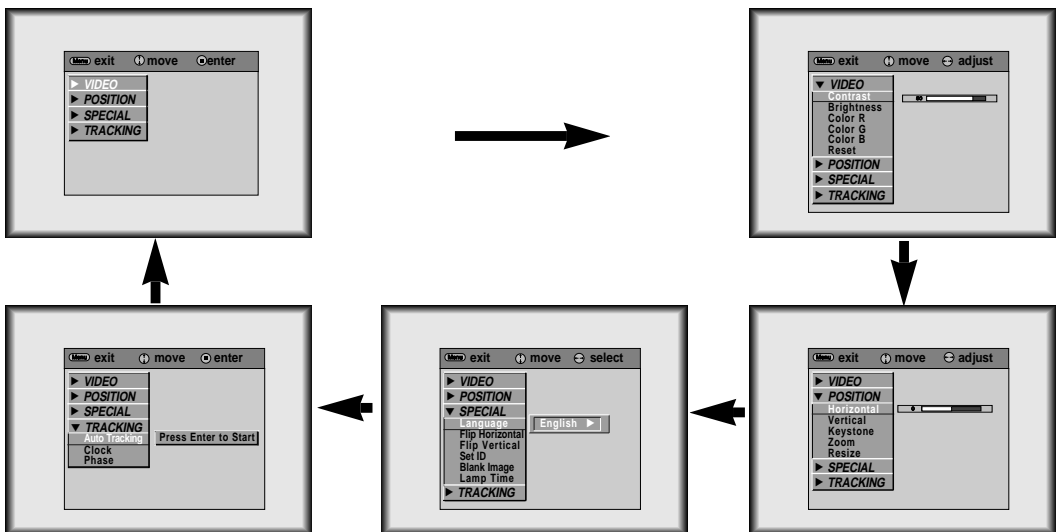

3 Move the **POINTER** button up or down to select a function that you want to use or adjust.

- To exit the menu display, press the **MENU** button.
- * In Video and S-Video mode and Component mode, [**Horizontal**], [**Vertical**] in POSITION menu and TRACKING menu are not displayed.
- * The sub menus of VIDEO menu in Video and S-Video mode and Component mode are different from those in the RGB mode. (Refer to page 47).

Using Still function

- 1 Press the **STILL** button.
* You can freeze the input image.



<Moving Image>



<Still Image>

-
- 2 To release this function, press the **STILL** button again.
* The STILL function would release automatically after about 10 minutes.

Selecting language

- 1** Press the **MENU** button and move the **POINTER** button up or down to select the **SPECIAL** menu as below.

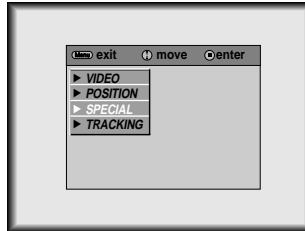

- 2** Press the **ENTER**(■) button and move the **POINTER** button up or down to select [Language] item.

Move the **POINTER** button left or right to select the language you want to use.

- 3**
- On-Screen-Display(OSD) is provided in the selected language from this point.
 - To exit the menu display, press the **MENU** button again.

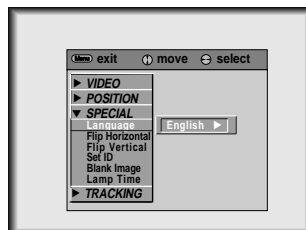

Using Blank function

* This function may be effective if you need to get attention of an audience during presentations, meetings or briefings.

1 Press the **BLANK** button.

* The screen turns off to a background color and sound also turns off.

* You can choose the background color. Refer to page 38.

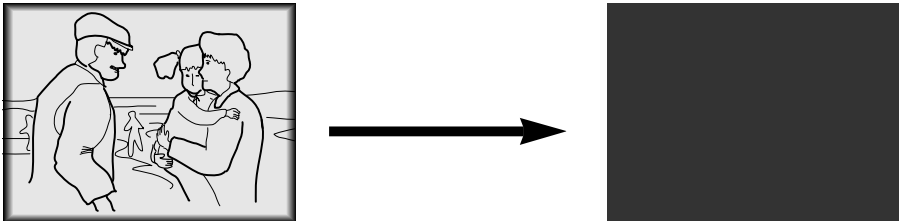

2 Press any buttons to cancel the blank function.

* On exiting the blank status sound also is restored.

Selecting Blank Image color

- 1** Press the **MENU** button and move the **POINTER** button up or down to select the **SPECIAL** menu.



- 2** Press the **ENTER** button and move the **POINTER** button up or down to select the **[Blank Image]** item.

- 3** Move the **POINTER** button left or right to select the color you want to use.

- Background color will be changed to the selected color from this point.
- To exit menu display, press the **MENU** button.

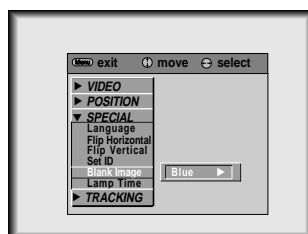

Using Flip Horizontal / Vertical function

Flip Horizontal Function

* This function reverses the left and the right side of the projected image. Use this function when projecting from behind onto a transparent screen being viewed from the opposite side(Rear Projection).

- 1 Press the **MENU** button and move the **POINTER** button up or down to select the SPECIAL menu.



- 2 Press the **ENTER**(■) button and move the **POINTER** button up or down to select [Flip Horizontal] item.

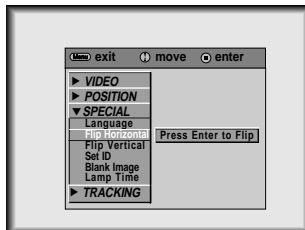

- 3 Press the **ENTER**(■) button to see reversed image.

- Each time you press the button, the image will be reversed.
- To finish menu display, press the **MENU** button.

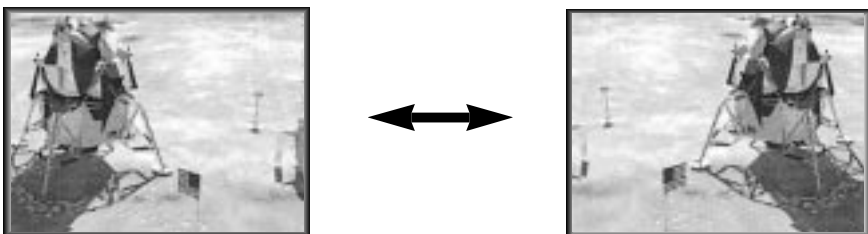

Flip Vertical Function

* This function reverses the upper and the lower side of the projected image.

* When you hang the projector upside down from the ceiling for using, you need to reverse all the sides(left, right, upper, lower) of the image.

- 1 Press the **MENU** button and move the **POINTER** button up or down to select the SPECIAL menu.

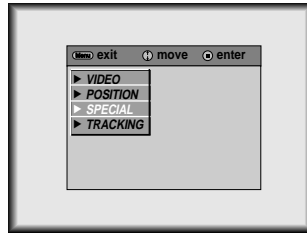

- 2 Press the **ENTER**(■) button and move the **POINTER** button up or down to select [Flip Vertical] item.

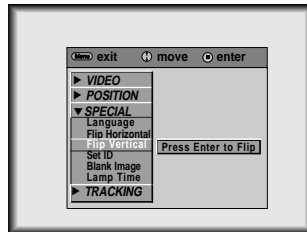

- 3 Press the **ENTER**(■) button to see reversed image.

- Each time you press the button, the image will be reversed.
- To finish menu display, press the **MENU** button.

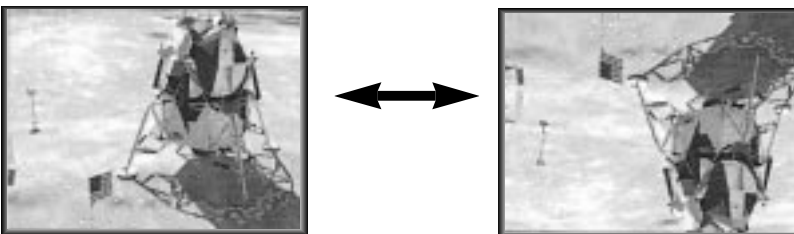

Checking lamp time

- 1 Press the **MENU** button and move the **POINTER** button up or down to select the SPECIAL menu as below.



- 2 Press the **ENTER**(■) button and move the **POINTER** button up or down to select the [Lamp Time] item.

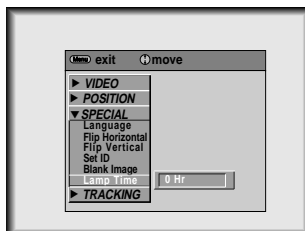

- The lamp hours used will be displayed.
- When projector lamp is reaching the end of its life(over 1900 hours), the lamp indicator will flash(red) and the projector will display "Replace the Lamp" on screen.

Using Resize function

* You can use this function only under SVGA (800x600) mode in RGB mode.

1 Press the **RESIZE** button.

Each press of the button changes the display as below.

< RGB mode >



Scaled



Original

< Video, S-Video, Component mode >



4 : 3

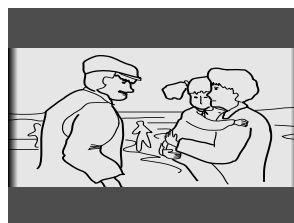

16 : 9

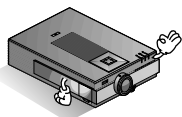

* You can also use this function by using the **MENU** button.

Adjusting screen display

Positioning

- * If the image size does not fit the screen in accordance with the input source, set the position of the image by selecting Horizontal / Vertical position.
- * It's available to operate [Horizontal], [Vertical] in analog RGB mode only.
- * **Keystone** function adjusts the upper and lower width of the projected image to prevent the image from being a trapezoid shape. Use this function when the screen or the projector is slanted and cannot make an ideal projection angle.

- 1 Press the **MENU** button and move the **POINTER** button up or down to select the POSITION menu.



- 2 Press the **ENTER** button and move the **POINTER** button up or down to select (Horizontal), (Vertical) or (Keystone) item.

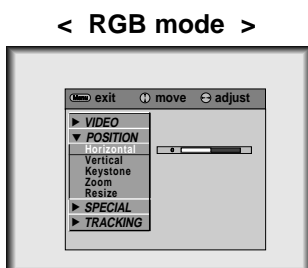

- 3 Press the **POINTER** button and move the button left or right or press the **VOLUME** (+, -) button to adjust the screen condition as you want.

- (Horizontal), (Vertical), (Keystone) are adjusted from -50 to +50.
- To exit the menu display, press the **MENU** button.

Zoom Function

- 1** Press the **ZOOM ▲, ▼** button.



- 2** Press the **ZOOM ▲, ▼** or **[L] MOUSE, [R] MOUSE** button to adjust the zoom level.

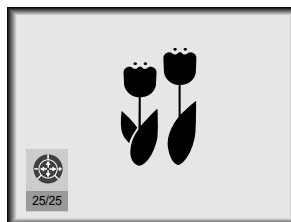
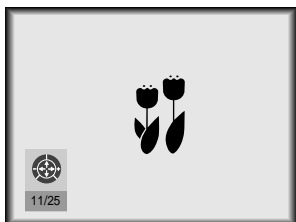

- 3** Move to the position you want to see the enlarged display by moving the **POINTER** button left, right, up, or down.

- 4** Press the **ENTER(■)** or **RESIZE, AUTO TRACKING** button again to exit the zoom function.

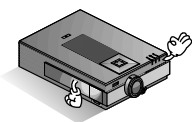

- * This function doesn't work in 720p, 1080i mode.
- * You can use this function by using the **MENU** button.
- * In the zoom mode, you can adjust horizontal / vertical position with the **POINTER** button.

Using Tracking function

Auto Tracking Function

* Auto Tracking Function

This function assures you of getting the best video quality by automatically adjusting the difference of horizontal size and synchronization of the image.

This function resets system setting if the projector doesn't recognize the video system in VIDEO mode.

- 1 Press the **AUTO TRACKING** button.

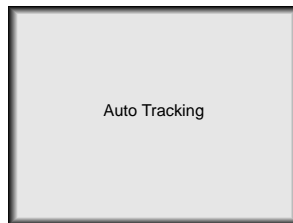

* Image positioning and synchronization are automatically adjusted.

-
- 2 Adjust [**Clock**] or [**Phase**] in TRACKING menu after operation of [**Auto Tracking**] if you want to get better picture quality in accordance with diverse PC input modes. (Refer to page 46.)

* It's available to adjust [Clock], [Phase] in analog RGB mode only.

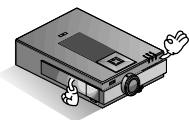

* You can also use this function by using the **MENU** button.(PC mode)

* It is best to perform this function while displaying a still image. Because you may not get the best video quality on a moving image of PC graphic signal.

Clock / Phase Function

* Clock Function

This function adjusts the horizontal width of the projected image to get the image to fit on the screen size.

* Phase Function

This function is for the detailed adjustment of the clock function.

* It's available to adjust [Clock], [Phase] in analog RGB mode only.

- 1 Press the **MENU** button and move the **POINTER** button up or down to select the TRACKING menu.

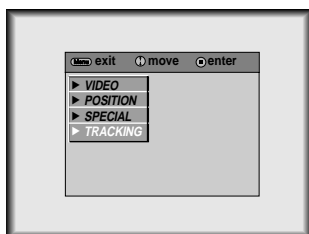

- 2 Press the **ENTER**(■) button and move the **POINTER** button up or down to select the (Clock) or (Phase) item.



- 3 Move the **POINTER** button left or right or press the **VOLUME** (+, -) button to adjust the screen condition.

- To exit the menu display, press the **MENU** button.

Adjusting Video

- 1** Press the **MENU** button and move the **POINTER** button up or down to select each VIDEO menu.

< RGB mode >

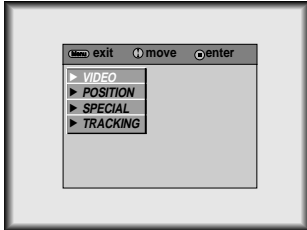

< Video, S-Video, Component mode >



- 2** Press the **ENTER**(**■**) button.

< RGB mode >



< Video, S-Video, Component mode >

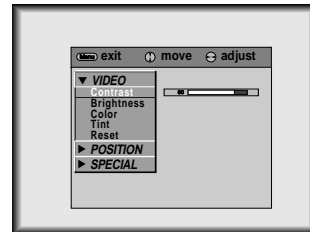

- 3** Move the **POINTER** button up or down to select a video item you want to adjust.

- 4** Move the **POINTER** button left or right or press the **VOLUME** (+, -) button to adjust the selected video item as you want.

- To restore the original image condition after changing it, press **ENTER** button after selecting (**Reset**) item.
- To finish menu display, press the **MENU** button.

External control device setup

- * This function doesn't supply the ASCII code communication(ex, Hyper Terminal). Refer to "RS-232 Protocol" (P. 51) to control the hexa code communication.
- * Connect the RS-232C input jack to an external control device (such as a computer or an A/V control system) and control the Projector's functions externally.



How to connect external control equipment

- Connect the serial port of the PC to the RS-232C jack on the projector back panel.

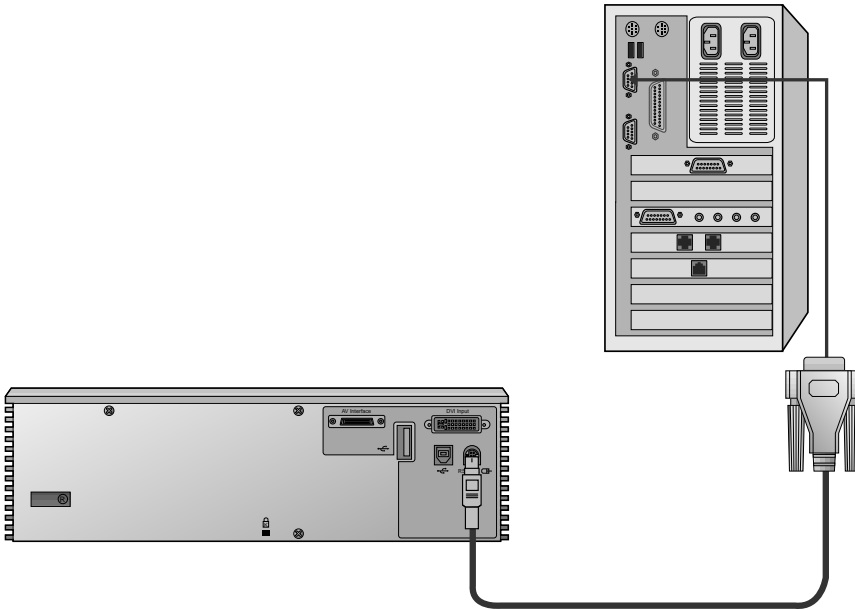

- If you want to extend the cable length, you can connect a Female 9 pin-Male 9 Extension Cable.

External control device setup

- Use the RS232C cable to control the projector externally (Refer to Fig.1).

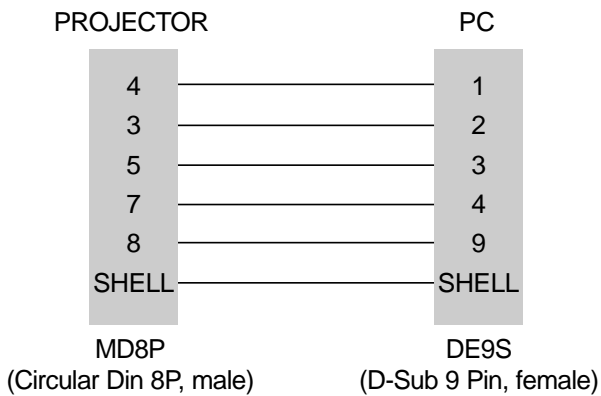

Fig.1,RS232C configuration

- If you want to extend the cable length, you can connect a Female 9 pin-Male 9 pin Extension Cable(Refer to Fig.2).

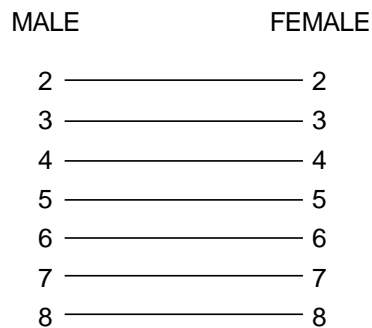
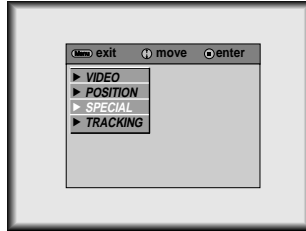

Fig.2,Female 9 Pin- Female 9 Pin configuration

SET ID(Multi Projector Installation)

- Use this function to specify projector ID number for remote control.

1 Press the **MENU** button and move the **POINTER** button up or down to select the SPECIAL menu.



2 Press the **ENTER** button and move the **POINTER** button up or down to select the (Set ID).

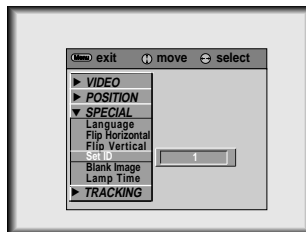

3 Move the **POINTER** button left or right to adjust Set ID to choose the desired projector ID number.

- The adjustment range of **Set ID** is 0~100.
- If projectors have specified ID numbers, then only the selected projector operates.
- To exit the menu display, press the **MENU** button.

RS-232 Protocol

Communication Parameter

- Baud Rate : 19200 bps
- Data bit:8
- Parity : none
- Stop bit : 1
- Flow Control : none
- Communication code : Hexa code
- COM Port : COM1, COM2, COM3, COM4

Command List

Key-code List

- | | |
|------------|----------------|
| 01. POWER | 12. STILL |
| 02. MENU | 13. ZOOM - |
| 03. SOURCE | 14. ZOOM + |
| 04. ENTER | 15. MUTE |
| 05. ▼ | 16. BLANK |
| 06. ◀ | 17. MOUSE L |
| 07. ▶ | 18. MOUSE R |
| 08. ▲ | 19. MOUSE DRAG |
| 09. - | 20. RESIZE |
| 10. + | 21. KEYSTONE - |
| 11. AUTO | 22. KEYSTONE + |

Operating List

- | | | |
|---------------|------------------------|--------|
| 01. RGB Video | Contrast | 0~100 |
| | Brightness | 0~100 |
| | Red | 0~100 |
| | Green | 0~100 |
| | Blue | 0~100 |
| 02. AV Video | Contrast | 0~100 |
| | Brightness | 0~100 |
| | Color | 0~100 |
| | Tint | 0~100 |
| 03. Setup | Keystone | 78~178 |
| | Flip Horizontal Toggle | |
| 04. Audio | Volume | 0~100 |

Protocol

Packet header

[Magic Number][Type][Payload Size][CRC]

[Magic Number] : It's a default value to confirm packet line up of 2 byte (0xEFBD-Set ID).

[Type] : 1 byte. It shows type of packet (key-code or operation).

[Payload Size] : 2 byte. It shows a data byte of Command Data (Packet Payload).

[CRC] : 2 byte. It shows CRC (Cyclic Redundancy Check). The CRC includes packet header and packetpayload.

Packet payload

- Keycode packet type

[Input Type][Input Action]

[Input Type] : 2 byte. It displays IR input or Keypad input.

[Input Action] : 2 byte. It shows a Keypcode.

Example : 0x25 shows left arrow button operation.

- Operation packet type

[Operation Action][Operation][Value]

[Operation Action]: It sets Set, Get, Initialize, Increment, Defrement, Execute.

[Operation] : It shows GUI operation ,such as Brightness, Contrast.

[Value] : It shows a value for set command which doesn't use other operation action.

key-code list

01.Power

[Magic Number][Type][Payload Size][CRC]

[Input Type][Input Action]

Magic Number : 0xEFBD-Set ID

Type 2 : Keypcode Type

Payload Size 4 : 4byte Payload size

Input Type 1 : IR Input

Input Action 18 : Power On/Off

02.Menu

[Magic Number][Type][Payload Size][CRC]

[Input Type][Input Action]

Magic Number : 0xEFBD-Set ID

Type 2 : Keypcode Type

Payload Size 4 : 4byte Payload size

Input Type 1 : IR Input

Input Action 17 : Menu On/Off

03. Input source

[Magic Number][Type][Payload Size][CRC]
 [Input Type][Input Action]

Magic Number : 0xEFBD-Set ID
 Type 2 : Keycode Type
 Payload Size 4 : 4byte Payload size
 Input Type 1 : IR Input
 Input Action 19 : Source select (PC/AV)

04. Enter

[Magic Number][Type][Payload Size][CRC]
 [Input Type][Input Action]

Magic Number : 0xEFBD-Set ID
 Type 2 : Keycode Type
 Payload Size 4 : 4byte Payload size
 Input Type 1 : IR Input
 Input Action 23 : Enter Execute

05. ▼

[Magic Number][Type][Payload Size][CRC]
 [Input Type][Input Action]

Magic Number : 0xEFBD-Set ID
 Type 2 : Keycode Type
 Payload Size 4 : 4byte Payload size
 Input Type 1 : IR Input
 Input Action 11 : Cursor Down Execute

06. ◀

[Magic Number][Type][Payload Size][CRC]
 [Input Type][Input Action]

Magic Number : 0xEFBD-Set ID
 Type 2 : Keycode Type
 Payload Size 4 : 4byte Payload size
 Input Type 1 : IR Input
 Input Action 12 : Cursor Down Execute

07. ▶

[Magic Number][Type][Payload Size][CRC]
 [Input Type][Input Action]

Magic Number : 0xEFBD-Set ID
 Type 2 : Keycode Type
 Payload Size 4 : 4byte Payload size
 Input Type 1 : IR Input
 Input Action 13 : Cursor Right Execute

08. ▲

[Magic Number][Type][Payload Size][CRC]
 [Input Type][Input Action]

Magic Number : 0xEFBD-Set ID
 Type 2 : Keycode Type
 Payload Size 4 : 4byte Payload size
 Input Type 1 : IR Input
 Input Action 14 : Cursor Up Execute

09. -

[Magic Number][Type][Payload Size][CRC]
 [Input Type][Input Action]

Magic Number : 0xEFBD-Set ID
 Type 2 : Keycode Type
 Payload Size 4 : 4byte Payload size
 Input Type 1 : IR Input
 Input Action 8 : Decrease

10. +

[Magic Number][Type][Payload Size][CRC]
 [Input Type][Input Action]

Magic Number : 0xEFBD-Set ID
 Type 2 : Keycode Type
 Payload Size 4 : 4byte Payload size
 Input Type 1 : IR Input
 Input Action 9 : Increase

External control device setup

11.Tracking

[Magic Number][Type][Payload Size][CRC]

[Input Type][Input Action]

Magic Number : 0xEFBD-Set ID
Type 2 : Keycode Type
Payload Size 4 : 4byte Payload size
Input Type 1 : IR Input
Input Action 2 : Auto Tracking Enable/Disable

15.Mute

[Magic Number][Type][Payload Size][CRC]

[Input Type][Input Action]

Magic Number : 0xEFBD-Set ID
Type 2 : Keycode Type
Payload Size 4 : 4byte Payload size
Input Type 1 : IR Input
Input Action 24 : Mute On/Off

12.Still

[Magic Number][Type][Payload Size][CRC]

[Input Type][Input Action]

Magic Number : 0xEFBD-Set ID
Type 2 : Keycode Type
Payload Size 4 : 4byte Payload size
Input Type 1 : IR Input
Input Action 5 : Still Enable/Disable

16.Blank

[Magic Number][Type][Payload Size][CRC]

[Input Type][Input Action]

Magic Number : 0xEFBD-Set ID
Type 2 : Keycode Type
Payload Size 4 : 4byte Payload size
Input Type 1 : IR Input
Input Action 25 : Blank On/Off

13.Zoom -

[Magic Number][Type][Payload Size][CRC]

[Input Type][Input Action]

Magic Number : 0xEFBD-Set ID
Type 2 : Keycode Type
Payload Size 4 : 4byte Payload size
Input Type 1 : IR Input
Input Action 32 : Zoom- Execute

17. Mouse L

[Magic Number][Type][Payload Size][CRC]

[Input Type][Input Action]

Magic Number : 0xEFBD-Set ID
Type 2 : Keycode Type
Payload Size 4 : 4byte Payload size
Input Type 1 : IR Input
Input Action 26 : Mouse left button On

14. Zoom +

[Magic Number][Type][Payload Size][CRC]

[Input Type][Input Action]

Magic Number : 0xEFBD-Set ID
Type 2 : Keycode Type
Payload Size 4 : 4byte Payload size
Input Type 1 : IR Input
Input Action 31 : Zoom+ Execute

18. Mouse R

[Magic Number][Type][Payload Size][CRC]

[Input Type][Input Action]

Magic Number : 0xEFBD-Set ID
Type 2 : Keycode Type
Payload Size 4 : 4byte Payload size
Input Type 1 : IR Input
Input Action 27 : Mouse right button On

19. Mouse drag

[Magic Number][Type][Payload Size][CRC]

[Input Type][Input Action]

Magic Number : 0xEFBD-Set ID
 Type 2 : Keycode Type
 Payload Size 4 : 4byte Payload size
 Input Type 1 : IR Input
 Input Action 15 : Mouse Drag Execute

20. Screen size

[Magic Number][Type][Payload Size][CRC]

[Input Type][Input Action]

Magic Number : 0xEFBD-Set ID
 Type 2 : Keycode Type
 Payload Size 4 : 4byte Payload size
 Input Type 1 : IR Input
 Input Action 8 : Resize Enable/Disable

21. Key stone -

[Magic Number][Type][Payload Size][CRC]

[Input Type][Input Action]

Magic Number : 0xEFBD-Set ID
 Type 2 : Keycode Type
 Payload Size 4 : 4byte Payload size
 Input Type 1 : IR Input
 Input Action 34 : Keystone- Execute

22. Key stone +

[Magic Number][Type][Payload Size][CRC]

[Input Type][Input Action]

Magic Number : 0xEFBD-Set ID
 Type 2 : Keycode Type
 Payload Size 4 : 4byte Payload size
 Input Type 1 : IR Input
 Input Action 33 : Keystone+ Execute

Operating List

01. RGB video
 a. Contrast

[Magic Number][Type][Payload Size][CRC]

[Operation Action][Operation][Value]

Magic Number : 0xEFBD-Set ID
 Type 3 : Operation Type
 Payload Size 6 : 6byte Payload size
 Operation Action1 : Operation Set
 Operation 2 : Contrast
 Value 0~100 : Contrast Value

Contrast default value

Operation Action1 : Operation Set
 Operation 2 : Contrast
 Value 80 : Contrast Value

Contrast setting value

Operation Action2 : Operation Get
 Operation 2 : Contrast
 Value 0~100 : Contrast Get Value

b. Brightness

[Magic Number][Type][Payload Size][CRC]

[Operation Action][Operation][Value]

Magic Number : 0xEFBD-Set ID
 Type 3 : Operation Type
 Payload Size 6 : 6byte Payload size
 Operation Action1 : Operation Set
 Operation 1 : Brightness
 Value 0~100 : Brightness Value

Brightness default value

Operation Action 1: Operation Set
 Operation 1 : Brightness
 Value 80 : Brightness Value

Brightness setting value

Operation Action 2: Operation Get
 Operation 1 : Contrast
 Value 0~100 : Contrast Get Value

External control device setup

c. Red

[Magic Number][Type][Payload Size][CRC]

[Operation Action][Operation][Value]

Magic Number : 0xEFBD-Set ID
Type 3 : Operation Type
Payload Size 6 : 6byte Payload size
Operation Action1 : Operation Set
Operation 29 : Red
Value 0~100 : Red Value

Red default value

Operation Action1 : Operation Set
Operation 29 : Red
Value 50 : Red Get Value

Red setting value

Operation Action2 : Operation Get
Operation 29 : Red
Value 0~100 : RedGet Value

d. Green

[Magic Number][Type][Payload Size][CRC]

[Operation Action][Operation][Value]

Magic Number : 0xEFBD-Set ID
Type 3 : Operation Type
Payload Size 6 : 6byte Payload size
Operation Action1 : Operation Set
Operation 30 : Green
Value 0~100 : Green Value

Green default value

Operation Action 1: Operation Get
Operation 30 : Green
Value 50 : Green Get Value

Green setting value

Operation Action 2: Operation Get
Operation 30 : Green
Value 0~100 : Green Get Value

e. Blue

[Magic Number][Type][Payload Size][CRC]

[Operation Action][Operation][Value]

Magic Number : 0xEFBD-Set ID
Type 3 : Operation Type
Payload Size 6 : 6byte Payload size
Operation Action1 : Operation Set
Operation 31 : Blue
Value 0~100 : Blue Value

Blue default value

Operation Action1 : Operation Set
Operation 31 : Blue
Value 50 : Blue Get Value

Blue setting value

Operation Action2 : Operation Get
Operation 31 : Blue
Value 0~100 : Blue Get Value

02. AV Video

a. Contrast

[Magic Number][Type][Payload Size][CRC]

[Operation Action][Operation][Value]

Magic Number : 0xEFBD-Set ID
Type 3 : Operation Type
Payload Size 6 : 6byte Payload size
Operation Action1 : Operation Set
Operation 60 : Contrast
Value 0~100 : Contrast Value

Contrast default value

Operation Action 1: Operation Set
Operation 60 : Contrast
Value 80 : Contrast Value

Contrast setting value

Operation Action 2: Operation Get
Operation 60 : Contrast
Value 0~100 : Contrast Get Value

b. Brightness

[Magic Number][Type][Payload Size][CRC]

[Operation Action][Operation][Value]

Magic Number : 0xEFBD-Set ID
 Type 3 : Operation Type
 Payload Size 6 : 6byte Payload size
 Operation Action1 : Operation Set
 Operation 59 : Brightness
 Value 0~100 : Brightness Value

Contrast default value

Operation Action1 : Operation Set
 Operation 59 : Brightness
 Value 80 : Brightness Value

Contrast setting value

Operation Action2 : Operation Get
 Operation 59 : Contrast
 Value 0~100 : Contrast Get Value

c. Color

[Magic Number][Type][Payload Size][CRC]

[Operation Action][Operation][Value]

Magic Number : 0xEFBD-Set ID
 Type 3 : Operation Type
 Payload Size 6 : 6byte Payload size
 Operation Action1 : Operation Set
 Operation 4 : Saturation
 Value 0~100 : Saturation Value

Color default value

Operation Action 1: Operation Get
 Operation 4 : Saturationn
 Value 50 : Saturation Get Value

Color setting value

Operation Action 2: Operation Get
 Operation 4 : Color
 Value 0~100 : Color Get Value

d. Tint

[Magic Number][Type][Payload Size][CRC]

[Operation Action][Operation][Value]

Magic Number : 0xEFBD-Set ID
 Type 3 : Operation Type
 Payload Size 6 : 6byte Payload size
 Operation Action1 : Operation Set
 Operation 3 : Tint
 Value 0~100 : Tint Value

Tint default value

Operation Action1 : Operation Set
 Operation 3 : Tint
 Value 50 : TintValue

Tint setting value

Operation Action2 : Operation Get
 Operation 3 : Tint
 Value 0~100 : Tint Get Value

03. Setup

a. Key stone

[Magic Number][Type][Payload Size][CRC]

[Operation Action][Operation][Value]

Magic Number : 0xEFBD-Set ID
 Type 3 : Operation Type
 Payload Size 6 : 6byte Payload size
 Operation Action1 : Operation Set
 Operation 22 : Keystone
 Value 78~178 : Keystone Value

Key stone default value

Operation Action 1: Operation Set
 Operation 22 : Keystone
 Value 128 : Keystone Value

Key stone setting value

Operation Action 2: Operation Get
 Operation 22 : Keystone
 Value 78~178 : Keystone Get Value

External control device setup



b. Flip Horizontal

[Magic Number][Type][Payload Size][CRC]

[Operation Action][Operation]

Magic Number : 0xEFBD-Set ID
Type 3 : Operation Type
Payload Size 6 : 6byte Payload size
Operation Action6 : Operation Execute
Operation 507 : Flip Horizontal

04. Audio

a. Volume

[Magic Number][Type][Payload Size][CRC]

[Operation Action][Operation][Value]

Magic Number : 0xEFBD-Set ID
Type 3 : Operation Type
Payload Size 6 : 6byte Payload size
Operation Action1 : Operation Set
Operation 531 : Volume
Value 0~100 : Volume Value

Volume default value

Operation Action 1: Operation Get
Operation 531 : Volume
Value 20 : Volume Value

Volume setting value

Operation Action 2: Operation Get
Operation 531 : Volume
Value 0~100 : Volume Get Value

Supported Monitor Display

* The projector displays images at a resolution of 1024x768 pixels. To display higher resolution images(1152x864mode, 1280x1024mode), the projector compresses it to 1024x768. The following table lists the display formats supported by the projector.

Sources	Format	Vertical Freq.(Hz)	Horizontal Freq.(kHz)
VGAEGA	640X350	70.090Hz	31.468kHz
	640X350	85.080Hz	37.861kHz
PC98 / VGA Text	640X400	85.080Hz	37.861kHz
	720X400	70.082Hz	31.469kHz
	720X400	85.039Hz	37.927kHz
VGA	640X480	59.940Hz	31.469kHz
	640X480	72.800Hz	37.861kHz
	640X480	75.00Hz	37.500kHz
	640X480	85.008Hz	43.269kHz
	640X480	100.040Hz	53.011kHz
	640X480	120.00Hz	64.062kHz
SVGA	800X600	56.250Hz	35.156kHz
	800X600	60.317Hz	37.879kHz
	800X600	72.188Hz	48.077kHz
	800X600	75.00Hz	46.875kHz
	800X600	85.061Hz	53.674kHz
	800X600	90.00Hz	56.00kHz
	800X600	100.00Hz	64.016kHz
XGA	1024X768	43.479Hz(interlace)	35.522kHz
	1024X768	60.004Hz	48.363kHz
	1024X768	70.069Hz	56.476kHz
	1024X768	75.029Hz	60.023kHz
	1024X768	84.997Hz	68.677kHz
SXGA	1152X864	60.053Hz	54.348kHz
	1152X864	70.016Hz	63.995kHz
	1152X864	75.00Hz	67.500kHz
	1152X864 ★	85.057Hz	77.487kHz
	1280X960	60.00Hz	60.00kHz
	1280X960	75.00Hz	75.00kHz
	1280X960 ★	85.002Hz	85.938kHz
	1280X1024	60.020Hz	63.981kHz
	1280X1024	75.025Hz	79.976kHz
MAC	16"	832X624	49.725kHz
	19"	1024X768	48.363kHz
		1024X768	60.241kHz
	20"	1152X870	68.681kHz
HD	1280X720p	60.00Hz	45.00kHz
	1280X720p	59.94Hz	44.96kHz
	1920X1080i	60.00Hz	33.750kHz
	1920X1080i	59.94Hz	33.72kHz

★ This resolution is applied only in Analog RGB input source.

* If the projector does not support the input signal, "CHECK INPUT SIGNAL" message appears on the screen.

* The projector supports DDC1/2B type as Plug & Play function.(Auto recognition of PC monitor)

* Synchronization input form : Separate, Composite

Maintenance

- * The projector needs little maintenance. You should keep the lens clean because any dirt or stains may appear on the screen. You will also need to clean the air filter attached at the top of the projector periodically because a clogged air filter prevents proper ventilation that is necessary to cool the projector and prevents it from overheating. If any parts need to be replaced, contact your dealer. When cleaning any part of the projector, always turn the power off and unplug the projector first.

Cleaning the lens

Clean the lens whenever you notice dirt or dust on the surface of it. Wipe the lens surface gently with an air spray or a soft, dry lint-free cloth.

To remove dirt or stains on the lens, moisten a soft cloth with water and a neutral detergent and wipe the lens surface gently.

Cleaning the Projector Case

To clean the projector case, first unplug the power cable. To remove dirt or dust, wipe the casing with a soft, dry, lint-free cloth. To remove stubborn dirt or stains, moisten a soft cloth with water and a neutral detergent and then wipe the casing.

Do not use alcohol, benzene, thinners or other chemical detergents as these can cause the casing to be warped.

Cleaning the Air Filter

The air filter, which is located at the top of the projector, should be cleaned after every 100 hours' use. If it is not cleaned periodically, it can become clogged with dust and prevent the projector from being ventilated properly. This may cause overheating and damage to the projector.

To clean the air filter :

1. Switch the projector off and unplug the power cable from the wall socket.
2. After inserting into the fixture hole of the air-filter, as shown by the arrow, with a pointed instrument such as a ballpoint pen, remove the filter cover while you pull in the direction of the projection lens.

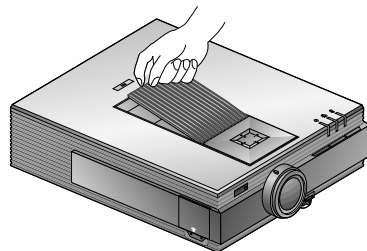
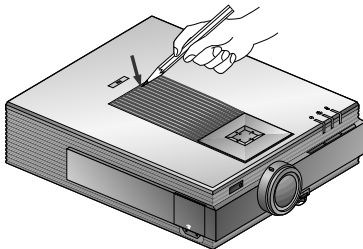

3. The air filter is inside the cover. To clean the filter, use a small vacuum cleaner or air-duster designed for computers or other office equipment. If not, you may use a dry cloth. If it is difficult to remove dirt or the filter is torn, contact your dealer or service center to replace it.
4. Close the filter cover after cleaning.
5. Plug the power cable back into the wall socket.

Specifications.

RL-JT10	Model
18mm(0.7 inches)	LCD panel size
1024(Horizontal) x 768(Vertical)pixel	resolution
1.02~5.1m(40~200 inches)	screen size
1.2~7.8m(3.94~25.6 feet)	projecting distance
9m	remote control distance
0.5W + 0.5W, stereo	speaker system
4:3(horizontal:vertical)	horizontal / vertical ratio
1:1.3	zoom ratio
NTSC/PAL/SECAM/NTSC4.43/PAL-M/PAL-N	Video compatibility
AC 100 - 240V~50/60Hz	Power
67mm	height
216mm	breadth
245mm	length
2.3kg	weight

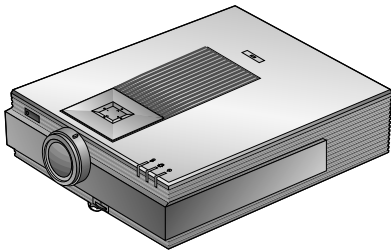

Warning

This is a class A product. In a domestic environment this product may cause radio interference, in which case the user may be required to take adequate measures.

Operating Condition

temperature

In operation : 32~95°F(0°C~35°C)
In storage and transit : -4~140°F(-20°C~60°C)

humidity

In operation : 20 ~ 80% relative humidity by dry hygrometer
Not in operation : 10 ~ 90% relative humidity by dry hygrometer

Projection Lamp

lamp model

AJ-LA40

power consumption

150W

