

# Multimedia Projector

## MODEL PLC-XU111 PLC-XU111K

# SANYO

### **Network Supported**

- Wireless LAN  
IEEE802.11b/g
- Wired LAN  
100-Base-TX/10-Base-T

### **Memory Viewer**

- USB Memory Viewer (optionally available)  
Compatible with a dedicated USB memory

*\*Refer to the owner's manuals below for details about network and memory viewer function.*

- Network Set-up and Operation
- Owner's Manual USB Memory

*This manual is provided with optionally supplied USB memory.*

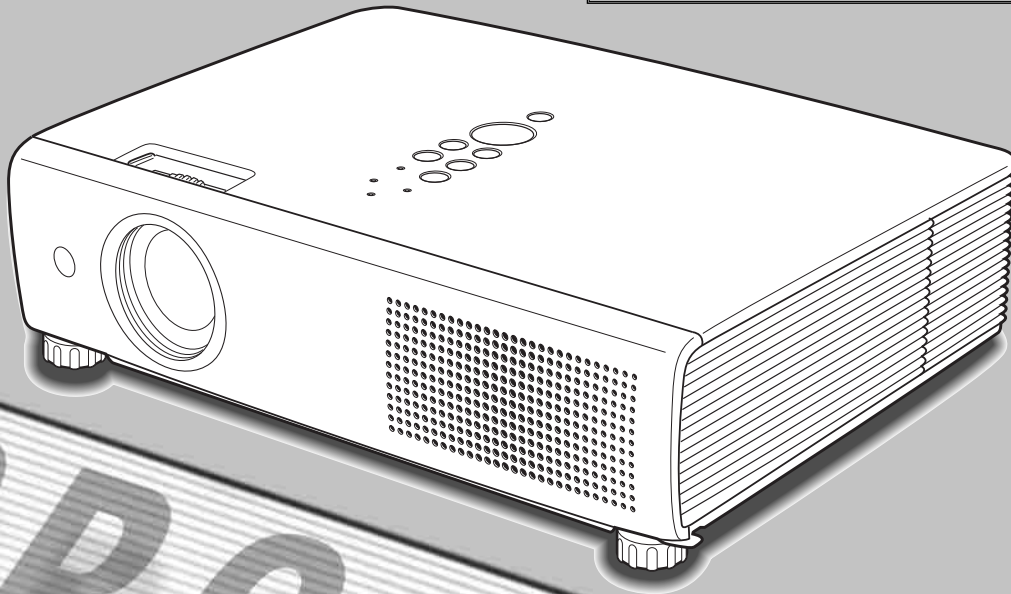

## Owner's Manual

# ProSelecta

View :: Compare :: Select - [www.ProSelecta.com](http://www.ProSelecta.com)



# Features and Design

This Multimedia Projector is designed with the most advanced technology for portability, durability, and ease of use. This projector utilizes built-in multimedia features, a palette of 16.77 million colors, and matrix liquid crystal display (LCD) technology.

## ◆ **Compact Design**

This projector is designed compact in size and weight. It is easy to carry and installed anywhere you wish to use.

## ◆ **Capable of 360-degree Projection**

This projector is capable of 360-degree projection.

\*Some restriction required, see page 8.

## ◆ **Antitheft Alarm Function**

This projector is equipped with an Antitheft alarm function which sounds when vibration is detected (pp.58–61). A built-in rechargeable battery is used for the alarm.

## ◆ **Simple Computer System Setting**

The projector has the Multi-scan system to conform to almost all computer output signals quickly (p.32). Up to UXGA resolution can be accepted.

## ◆ **Useful Functions for Presentations**

- The digital zoom function allows you to focus on the crucial information during a presentation (p.39).

- Blackboards\* can be used as a projection screen.

\*The board color is limited to Green (pp.36, 43).

## ◆ **Power Management**

The Power management function reduces power consumption and maintains the lamp life (p.52).

## ◆ **Lamp Control**

Brightness of the projection lamp can be selected (pp.28, 53).

## ◆ **Quick Termination**

The AC power cord can be unplugged immediately after turning off the projector without waiting for the termination of the cooling fan rotation (p.23).

## ◆ **Logo Function**

The Logo function allows you to customize the screen logo (pp.49–50). You can capture an image for the screen logo and use it for the starting-up display or between presentations.

## ◆ **Multilanguage Menu Display**

Operation menu is available in 16 languages; English, German, French, Italian, Spanish, Portuguese, Dutch, Swedish, Finnish, Polish, Hungarian, Romanian, Russian, Chinese, Korean, and Japanese (p.47).

## ◆ **Security Function**

The Security function helps you to ensure security of the projector. With the Key lock function, you can lock the operation on the top control or remote control (p.54). PIN code lock functions prevents unauthorized use of the projector (pp.22, 54–55).

## ◆ **Helpful Maintenance Functions**

Lamp and filter maintenance functions provide for better and proper maintenance of the projector.

## ◆ **LAN Network Function**

This projector is loaded with the Wired and Wireless LAN network function. You can project an image on a computer as well as operate and manage the projector via network. For details, refer to the owner's manual "Network Set-up and Operation."

## ◆ **Memory Viewer Function (Optional Function)**

Insert the dedicated USB memory (optionally supplied: POA-USB02) into the projector to project images or presentation data stored within. You do not have to carry computers or other equipment for a presentation

\*For details, refer to the owner's manual provided with optionally supplied USB memory.

### ✓ **Notes:**

- The On-Screen Menu and figures in this manual may differ slightly from the product.
- The contents of this manual are subject to change without notice.

# Table of Contents

<b>Features and Design</b> .....	<b>3</b>	<b>Computer Input</b> .....	<b>30</b>
<b>Table of Contents</b> .....	<b>4</b>	Input Source Selection (RGB: Computer 1 (Analog)/Computer 2 )	30
<b>To the Owner</b> .....	<b>5</b>	Input Source Selection (RGB (PC digital), RGB (AV HDCP))	31
<b>Safety Instructions</b> .....	<b>6</b>	Computer System Selection	32
Air Circulation	7	Auto PC Adjustment	33
Moving the Projector	7	Manual PC Adjustment	34
Installing the Projector in Proper Directions	8	Image Mode Selection	36
<b>Compliance</b> .....	<b>9</b>	Image Adjustment	37
<b>Part Names and Functions</b> .....	<b>10</b>	Screen Size Adjustment	38
Front	10	<b>Video Input</b> .....	<b>40</b>
Back	10	Input Source Selection (Video, S-video)	40
Bottom	10	Input Source Selection (Component, RGB Scart 21-pin)	41
Rear Terminal	11	Video System Selection	42
Top Control	12	Image Mode Selection	43
Remote Control	13	Image Adjustment	44
Laser Pointer Function	14	Screen Size Adjustment	46
Pointer Function	14	<b>Setting</b> .....	<b>47</b>
Wireless Mouse Operation	15	Setting	47
Remote Control Code	15	<b>Antitheft Alarm Function</b> .....	<b>58</b>
Remote Control Battery Installation	16	How to Use the Antitheft Alarm Function	58
Remote Control Operating Range	16	<b>Maintenance and Cleaning</b> .....	<b>62</b>
Adjustable Feet	16	Warning Indicator	62
<b>Installation</b> .....	<b>17</b>	Cleaning the Filter	63
Positioning the Projector	17	Resetting the Filter Counter	63
Connecting the AC Power Cord	18	Slide Shutter	64
Connecting to a Computer	19	Cleaning the Projection Lens	64
Connecting to Video Equipment	20	Cleaning the Projector Cabinet	64
Connecting to Component Video Equipment	21	Lamp Replacement	65
<b>Basic Operation</b> .....	<b>22</b>	Resetting the Lamp Counter	66
Turning On the Projector	22	<b>Appendix</b> .....	<b>67</b>
Turning Off the Projector	23	Troubleshooting	67
How to Operate the On-Screen Menu	24	Menu Tree	69
Menu Bar	25	Indicators and Projector Condition	71
Zoom and Focus Adjustment	26	Compatible Computer Specifications	72
Auto Setup Function	26	Technical Specifications	74
Keystone Correction	26	Optional Parts	75
Sound Adjustment	27	PJ Link Notice	76
Remote Control Operation	28	Configurations of Terminals	77
		PIN Code Number Memo	78
		Dimensions	79

## Trademarks

Each name of corporations or products in this book is either a registered trademark or a trademark of its respective corporation.





# To the Owner

Before installing and operating this projector, read this manual thoroughly.

This projector provides many convenient features and functions. Operating the projector properly enables you to manage those features and maintains it in good condition for many years to come.

Improper operation may result in not only shortening the product-life, but also malfunctions, fire hazard, or other accidents.

If your projector seems to operate improperly, read this manual again, check operations and cable connections and try the solutions in the "Troubleshooting" section in the back of this booklet. If the problem still persists, contact the dealer where you purchased the projector or the service center.

	<b>CAUTION</b> <b>RISK OF ELECTRIC SHOCK</b> <b>DO NOT OPEN</b>	
<b>CAUTION: TO REDUCE THE RISK OF ELECTRIC SHOCK, DO NOT REMOVE COVER (OR BACK). NO USER-SERVICEABLE PARTS INSIDE EXCEPT LAMP REPLACEMENT. REFER SERVICING TO QUALIFIED SERVICE PERSONNEL.</b>		
	THIS SYMBOL INDICATES THAT DANGEROUS VOLTAGE CONSTITUTING A RISK OF ELECTRIC SHOCK IS PRESENT WITHIN THIS UNIT.	
	THIS SYMBOL INDICATES THAT THERE ARE IMPORTANT OPERATING AND MAINTENANCE INSTRUCTIONS IN THE OWNER'S MANUAL WITH THIS UNIT.	

**NOTE:** This symbol and recycle system are applied only to EU countries and not applied to the countries in the other area of the world.



Your SANYO product is designed and manufactured with high quality materials and components which can be recycled and reused.

This symbol means that electrical and electronic equipment, at their end-of-life, should be disposed of separately from your household waste.

Please dispose of this equipment at your local community waste collection/recycling centre.

In the European Union there are separate collection systems for used electrical and electronic products.

Please help us to conserve the environment we live in!

**READ AND KEEP THIS OWNER'S MANUAL FOR LATER USE.**



## Safety Precaution

**WARNING: TO REDUCE THE RISK OF FIRE OR ELECTRIC SHOCK, DO NOT EXPOSE THIS APPLIANCE TO RAIN OR MOISTURE.**

- This projector produces intense light from the projection lens. Do not stare directly into the lens, otherwise eye damage could result. Be especially careful that children do not stare directly into the beam.
- Install the projector in a proper position. Otherwise it may result in fire hazard.
- Allowing the proper amount of space on the top, sides, and rear of the projector cabinet is critical for proper air circulation and cooling of the unit. The dimension shown here indicate the minimum space required. If the projector is to be built into a compartment or similarly enclosed, these minimum distances must be maintained.

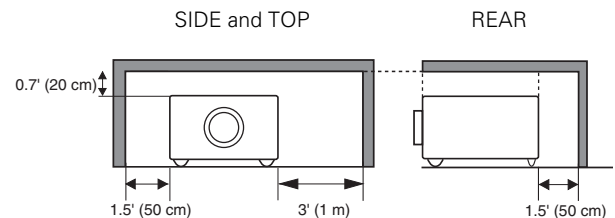

- Do not cover the ventilation slot on the projector. Heat build-up can reduce the service life of your projector, and can also be dangerous.
- If the projector is unused for an extended time, unplug the projector from the power outlet.



## CAUTION

**DO NOT SET THE PROJECTOR IN GREASY, WET, OR SMOKY CONDITIONS SUCH AS IN A KITCHEN TO PREVENT A BREAKDOWN OR A DISASTER. IF THE PROJECTOR COMES IN CONTACT WITH OIL OR CHEMICALS, IT MAY BECOME DETERIORATED.**

## CAUTION

Not for use in a computer room as defined in the Standard for the Protection of Electronic Computer/Data Processing Equipment, ANSI/NFPA 75.

Ne peut être utilisé dans une salle d'ordinateurs telle que définie dans la norme ANSI/NFPA 75 Standard for Protection of Electronic Computer/Data Processing Equipment

# Safety Instructions

All the safety and operating instructions should be read before the product is operated.

Read all of the instructions given here and retain them for later use. Unplug this projector from AC power supply before cleaning. Do not use liquid or aerosol cleaners. Use a damp cloth for cleaning.

Follow all warnings and instructions marked on the projector.

For added protection to the projector during a lightning storm, or when it is left unattended and unused for long periods of time, unplug it from the wall outlet. This will prevent damage due to lightning and power line surges.

---

Do not expose this unit to rain or use near water... for example, in a wet basement, near a swimming pool, etc...

Do not use attachments not recommended by the manufacturer as they may cause hazards.

Do not place this projector on an unstable cart, stand, or table. The projector may fall, causing serious injury to a child or adult, and serious damage to the projector. Use only with a cart or stand recommended by the manufacturer, or sold with the projector. Wall or shelf mounting should follow the manufacturer's instructions, and should use a mounting kit approved by the manufacturers.

An appliance and cart combination should be moved with care. Quick stops, excessive force, and uneven surfaces may cause the appliance and cart combination to overturn.



---

Slots and openings in the back and bottom of the cabinet are provided for ventilation, to ensure reliable operation of the equipment and to protect it from overheating.

The openings should never be covered with cloth or other materials, and the bottom opening should not be blocked by placing the projector on a bed, sofa, rug, or other similar surface. This projector should never be placed near or over a radiator or heat register.

This projector should not be placed in a built-in installation such as a book case unless proper ventilation is provided.

Never push objects of any kind into this projector through cabinet slots as they may touch dangerous voltage points or short out parts that could result in a fire or electric shock. Never spill liquid of any kind on the projector.

Do not install the projector near the ventilation duct of air-conditioning equipment.

This projector should be operated only from the type of power source indicated on the marking label. If you are not sure of the type of power supplied, consult your authorized dealer or local power company.

Do not overload wall outlets and extension cords as this can result in fire or electric shock. Do not allow anything to rest on the power cord. Do not locate this projector where the cord may be damaged by persons walking on it.

Do not attempt to service this projector yourself as opening or removing covers may expose you to dangerous voltage or other hazards. Refer all servicing to qualified service personnel.

Unplug this projector from wall outlet and refer servicing to qualified service personnel under the following conditions:

- a. When the power cord or plug is damaged or frayed.
- b. If liquid has been spilled into the projector.
- c. If the projector has been exposed to rain or water.
- d. If the projector does not operate normally by following the operating instructions. Adjust only those controls that are covered by the operating instructions as improper adjustment of other controls may result in damage and will often require extensive work by a qualified technician to restore the projector to normal operation.
- e. If the projector has been dropped or the cabinet has been damaged.
- f. When the projector exhibits a distinct change in performance-this indicates a need for service.

When replacement parts are required, be sure the service technician has used replacement parts specified by the manufacturer that have the same characteristics as the original part. Unauthorized substitutions may result in fire, electric shock, or injury to persons.

Upon completion of any service or repairs to this projector, ask the service technician to perform routine safety checks to determine that the projector is in safe operating condition.



## Voor de klanten in Nederland

Bij dit produkt zijn batterijen geleverd.

Wanneer deze leeg zijn, moet u ze niet weggooien maar inleveren als KCA.



## **Air Circulation**

Openings in the cabinet are provided for ventilation. To ensure reliable operation of the product and to protect it from overheating, these openings must not be blocked or covered.



### **CAUTION**

Hot air is exhausted from the exhaust vent. When using or installing the projector, the following precautions should be taken.

- Do not put any flammable object or spray can near the projector, hot air is exhausted from the air vents.
- Keep the exhaust vent at least 3' (1 m) away from any objects.
- Do not touch a peripheral part of the exhaust vent, especially screws and metallic parts. These areas will become hot while the projector is being used.
- Do not put anything on the cabinet. Objects put on the cabinet will not only get damaged but also may cause fire hazard by heat.

Cooling fans are provided to cool down the projector. The fans' running speed is changed according to the temperature inside the projector.

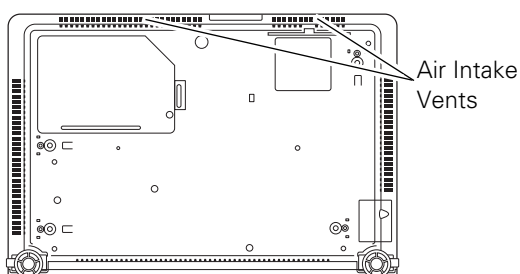
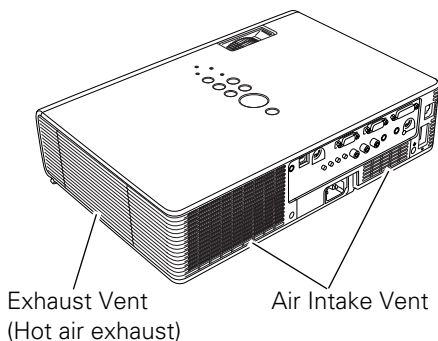
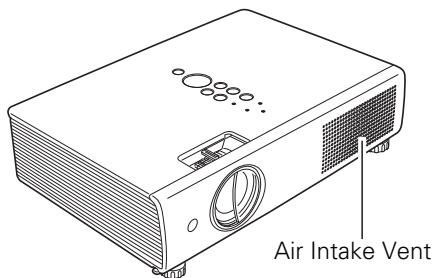

## **Moving the Projector**

When moving the projector, close the slide shutter and retract adjustable feet to prevent damage to the lens and cabinet.

When the projector is not in use for an extended period, put it into the supplied carrying case with the lens side up.



### **CAUTION**

The carrying case (supplied) is intended for protection against dust and scratches on surface of the cabinet, and it is not designed to protect an appliance from external forces. Do not transport the projector by courier or any other transport service with this case, otherwise the projector can be damaged. When handling the projector, do not drop, bump, subject it to strong forces, or put other things on the cabinet.



### **CAUTION IN CARRYING OR TRANSPORTING THE PROJECTOR**

- Do not drop or bump the projector, otherwise damages or malfunctions may result.
- When carrying the projector, use a suitable carrying case.
- Do not transport the projector by courier or any other transport service in an unsuitable transport case. This may cause damage to the projector. For information about transporting the projector by courier or any other transport service, consult your dealer.
- Do not put the projector in a case before the projector is cooled enough.

## Installing the Projector in Proper Directions

Use the projector properly in specified positions. Improper positioning may reduce the lamp life and result in severe accident or fire hazard.

This projector can project the picture upward, downward, or backward, perpendicular to the plane of the screen as shown in the figure below.

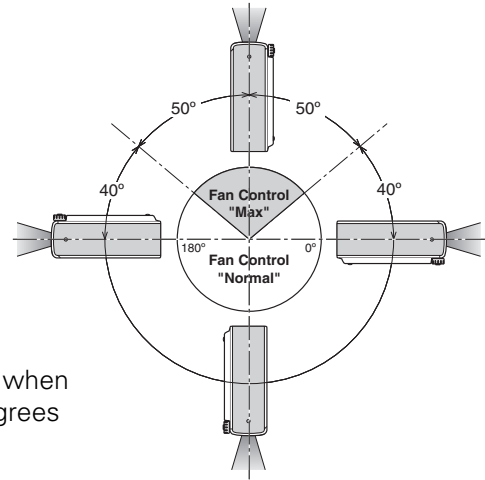
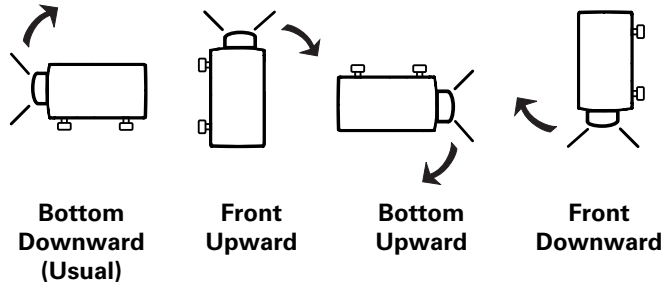

Be sure to set the Fan control in MAX in the setting menu when the projector is inclined between +40 degrees to +140 degrees to the horizontal plane (p.56).

## Positioning Precautions

Avoid positioning the projector as described below when installing.

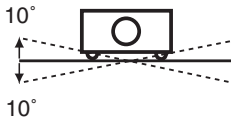

Do not tilt the projector more than 10 degrees from side to side.



Do not put the projector on either side to project an image.

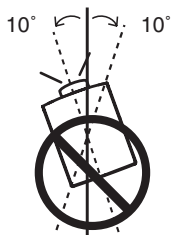

In upward projection, do not tilt the projector over 10 degrees right and left.

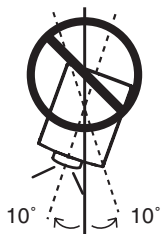

In downward projection, do not tilt the projector over 10 degrees right and left.



## Federal Communications Commission Notice

This equipment has been tested and found to comply with the limits for a Class B digital device, pursuant to Part 15 of the FCC Rules. These limits are designed to provide reasonable protection against harmful interference in a residential installation. This equipment generates, uses, and can radiate radio frequency energy and, if not installed and used in accordance with the instructions, may cause harmful interference to radio communications. However, there is no guarantee that interference will not occur in a particular installation. If this equipment does cause harmful interference to radio or television reception, which can be determined by turning the equipment off and on, the user is encouraged to try to correct the interference by one or more of the following measures:

- Reorient or relocate the receiving antenna.
- Increase the separation between the equipment and receiver.
- Connect the equipment into an outlet on a circuit different from that to which the receiver is connected.
- Consult the dealer or an experienced radio/TV technician for help.

Use of shielded cable is required to comply with class B limits in Subpart B of Part 15 of FCC Rules.

Do not make any changes or modifications to the equipment unless otherwise specified in the instructions. If such changes or modifications should be made, you could be required to stop operation of the equipment.

Model Number(s) : PLC-XU111  
Trade Name : Sanyo  
Responsible party : SANYO FISHER COMPANY  
Address : 21605 Plummer Street, Chatsworth, California 91311 U.S.A.  
Telephone No. : (818)998-7322

## AC Power Cord Requirement

The AC Power Cord supplied with this projector meets the requirement for use in the country you purchased it.

### AC Power Cord for the United States and Canada:

AC Power Cord used in the United States and Canada is listed by the Underwriters Laboratories (UL) and certified by the Canadian Standard Association (CSA).

AC Power Cord has a grounding-type AC line plug. This is a safety feature to be sure that the plug will fit into the power outlet. Do not try to defeat this safety feature. Should you be unable to insert the plug into the outlet, contact your electrician.



### AC Power Cord for the United Kingdom:

This cord is already fitted with a moulded plug incorporating a fuse, the value of which is indicated on the pin face of the plug. Should the fuse need to be replaced, an ASTA approved BS 1362 fuse must be used of the same rating, marked thus  $\diamond$ . If the fuse cover is detachable, never use the plug with the cover omitted. If a replacement fuse cover is required, ensure it is of the same colour as that visible on the pin face of the plug (i.e. red or orange). Fuse covers are available from the Parts Department indicated in your User Instructions. If the plug supplied is not suitable for your socket outlet, it should be cut off and destroyed. The end of the flexible cord should be suitably prepared and the correct plug fitted.

**WARNING: A PLUG WITH BARED FLEXIBLE CORD IS HAZARDOUS IF ENGAGED IN A LIVE SOCKET OUTLET.**

The Wires in this mains lead are coloured in accordance with the following code:

Green-and-yellow ..... Earth  
Blue ..... Neutral  
Brown ..... Live

As the colours of the wires in the mains lead of this apparatus may not correspond with the coloured markings identifying the terminals in your plug proceed as follows:

The wire which is coloured green-and-yellow must be connected to the terminal in the plug which is marked by the letter E or by the safety earth symbol  $\perp$  or coloured green or green-and-yellow.

The wire which is coloured blue must be connected to the terminal which is marked with the letter N or coloured black.

The wire which is coloured brown must be connected to the terminal which is marked with the letter L or coloured red.

**WARNING: THIS APPARATUS MUST BE EARTHED.**

**THE SOCKET-OUTLET SHOULD BE INSTALLED NEAR THE EQUIPMENT AND EASILY ACCESSIBLE.**

# Part Names and Functions

**Front**

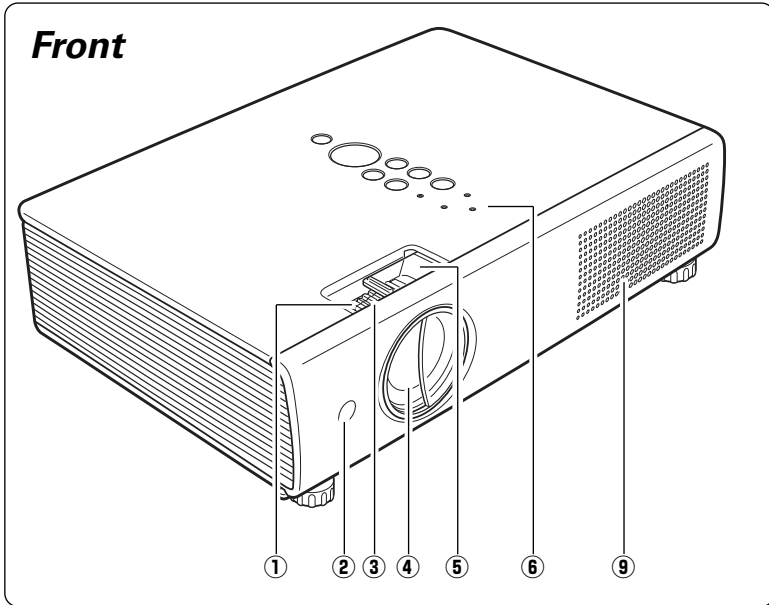

- ① Zoom Ring
- ② Infrared Remote Receiver
- ③ Focus Ring
- ④ Projection Lens
- ⑤ Slide Shutter Lever
- ⑥ Top Controls and Indicators
- ⑦ Exhaust Vent

**⚠ CAUTION**

Hot air is exhausted from the exhaust vents. Do not put heat-sensitive objects near this side.

**Back**

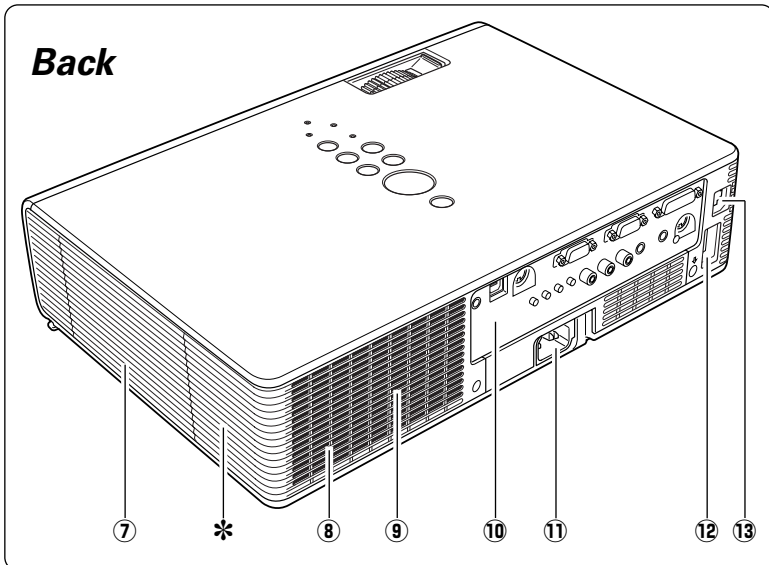

- ⑧ Speaker
- ⑨ Air Intake Vents
- ⑩ Terminals and Connectors
- ⑪ Power Cord Connector
- ⑫ USB Terminal
- ⑬ LAN Connection Terminal
- ⑭ Lamp Cover
- ⑮ Air Filter
- ⑯ Adjustable Feet
- ⑰ Battery Cover

**\* Kensington Security Slot**

This slot is for a Kensington lock used to deter theft of the projector.

\* Kensington is a registered trademark of ACCO Brands Corporation.

**Bottom**

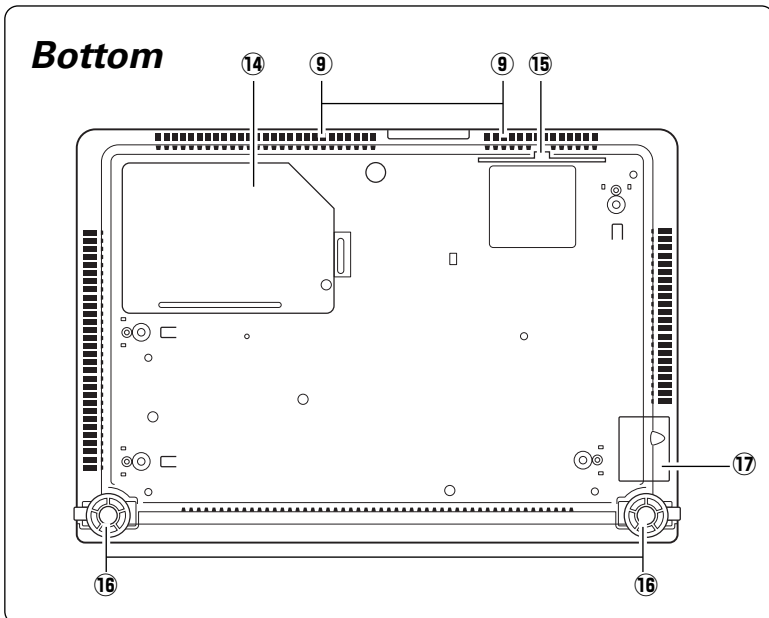

**✓Note:**

- ⑫ USB Terminal and ⑬ LAN Connection Terminal are for the Network function. Refer to the owner's manual "Network Set-up and Operation" and owner's manual of Memory viewer (optionally available).

## Rear Terminal

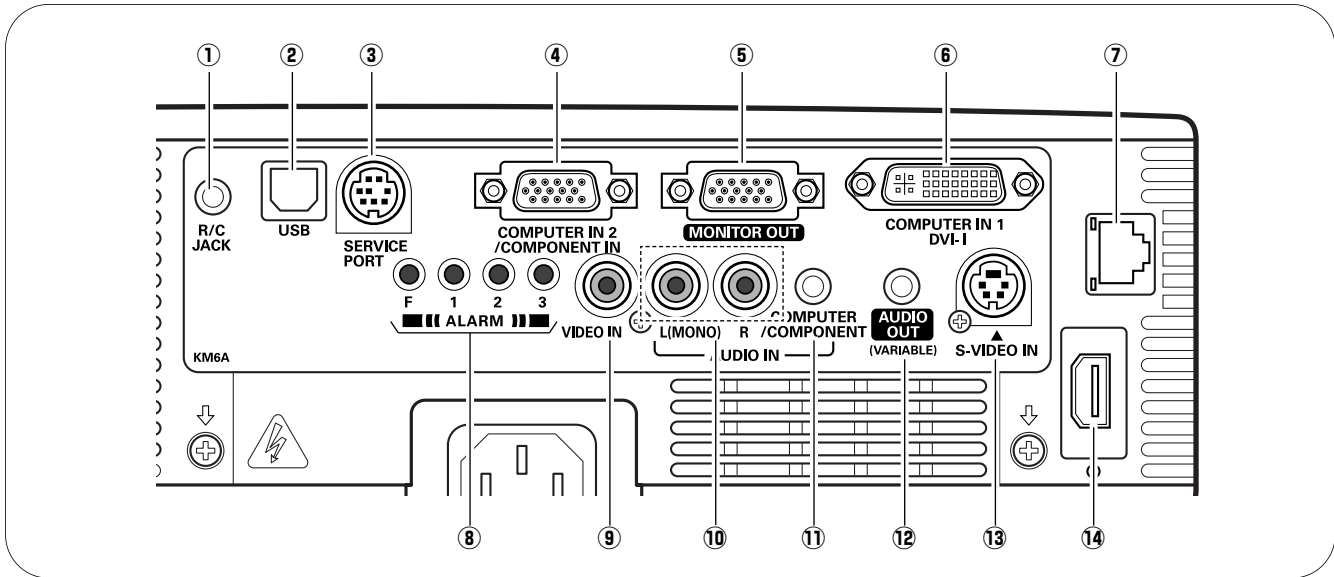

- ① R/C JACK**  
When using the wired remote control, connect the wired remote control to this jack with a remote control cable (not supplied).
- ② USB (Series B)**  
In order to operate the computer with the remote control and use the PAGE ▲▼ buttons on the remote control during a presentation, connect the USB port of the computer to the USB terminal with a USB cable (not supplied) (pp.13, 19).
- ③ SERVICE PORT**  
This jack is used to service the projector.
- ④ COMPUTER IN 2/COMPONENT IN**  
Connect the computer or component video (or RGB Scart) output signal to this terminal (pp.19, 21). Use the supplied VGA cable or a Component-VGA cable commercially available.
- ⑤ MONITOR OUT**  
This terminal can be used to output the incoming RGB analog signal from COMPUTER IN 1 and COMPUTER IN 2/COMPONENT IN terminal to the other monitor (p.19).
- ⑥ COMPUTER IN 1/DVI-I**  
Connect computer output (Digital/Analog DVI-I type) to this terminal (p.19).
- ⑦ LAN Connection Terminal**  
Connect the LAN cable (refer to the owner's manual "Network Set-up and Operation").
- ⑧ ALARM buttons**  
Use these buttons when setting up the Alarm function (pp.58–59).
- ⑨ VIDEO IN**  
Connect the composite video output signal to this jack (p.20).
- ⑩ AUDIO IN**  
Connect the audio output signal from video equipment connected to ⑨ or ⑬ to this jack. For a mono audio signal (a single audio jack), connect it to the L (MONO) jack (p.20).
- ⑪ COMPUTER/COMPONENT AUDIO IN**  
Connect the audio output (stereo) signal from a computer or video equipment connected to ④ or ⑥ to this jack (pp.19, 21).
- ⑫ AUDIO OUT (VARIABLE)**  
Connect an external audio amplifier to this jack (pp.19–21). This terminal outputs sound from AUDIO IN terminal (⑩ or ⑪).
- ⑬ S-VIDEO IN**  
Connect the S-VIDEO output signal from video equipment to this jack (p.20).
- ⑭ USB (Series A)**  
Connect the supplied USB Wireless LAN Adapter or optionally available USB memory for Memory viewer operation (refer to the owner's manual supplied with the optionally available USB memory).

Top Control

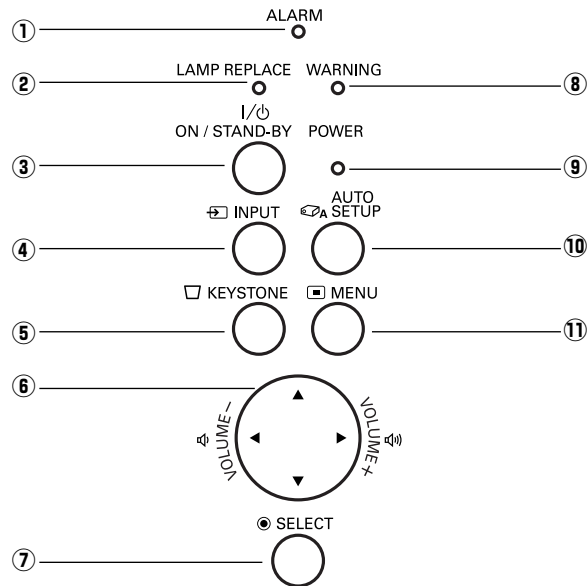

- ① **ALARM indicator**  
Blinks red when informing the setting or battery status (pp.58–59).
- ② **LAMP REPLACE indicator**  
Lights yellow when the projection lamp reaches its end of life (pp.65, 71).
- ③ **ON/STAND-BY button**  
Turn the projector on or off (pp.22–23).
- ④ **INPUT button**  
Select an input source (pp.30–31, 40–41).
- ⑤ **KEYSTONE button**  
Correct keystone distortion (pp.26, 48).
- ⑥ **POINT ▲▼◀▶ (VOLUME +/-) buttons**  
–Select an item or adjust the value in the On-Screen Menu (p.24).  
–Pan the image in the Digital zoom + mode (p.39).  
–Adjust the volume level (Point ◀▶ buttons) (p.27).
- ⑦ **SELECT button**  
–Execute the selected item (p.24).  
–Expand or compress the image in the Digital zoom mode (p.39).
- ⑧ **WARNING indicator**  
–Lights red when the projector detects an abnormal condition.  
–Blinks red when the internal temperature of the projector exceeds the operating range (pp.62, 71).
- ⑨ **POWER indicator**  
–Lights red when the projector is in stand-by mode.  
–Lights green during operations.  
–Blinks green in the Power management mode (p.52).
- ⑩ **AUTO SETUP button**  
Correct vertical keystone distortion and adjust computer display parameters such as Fine sync., Total dots, and Picture position (pp.26, 47).
- ⑪ **MENU button**  
Open or close the On-Screen Menu (p.24).

## Remote Control

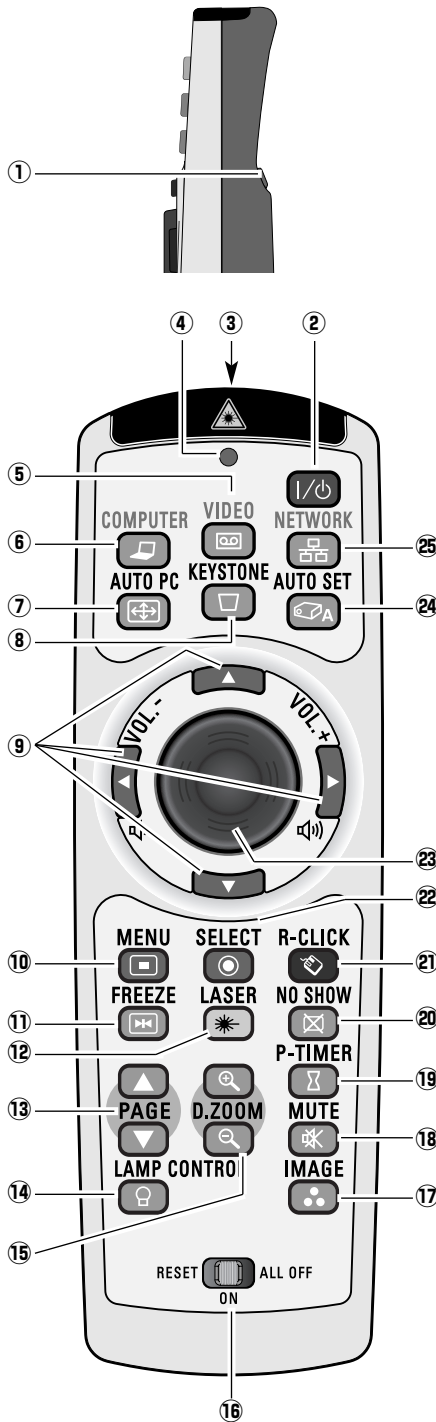

To ensure safe operation, please observe the following precautions:

- Do not bend, drop, or expose the remote control to moisture or heat.
- For cleaning, use a soft dry cloth. Do not apply benzene, thinner, splay, or any chemical material.

- L-CLICK button**  
Act as the left mouse button for wireless mouse operation (p.15).
- ON/STAND-BY button**  
Turn the projector on or off (pp.22–23).
- WIRED REMOTE jack**  
Connect the remote control cable (not supplied) to this jack when using as a wired remote control.
- SIGNAL EMISSION indicator**  
Lights red while the laser beam is being emitted from the laser light window or a signal is being sent from the remote control to the projector.
- VIDEO button**  
Select the VIDEO input source (p.40).
- COMPUTER button**  
Select the COMPUTER input source (pp.30–31, 41).
- AUTO PC button**  
Automatically adjust the computer image to its optimum setting (pp.28, 33, 47).
- KEystone button**  
Correct keystone distortion (pp.26, 48).
- Point ▲▼◀▶ (VOLUME +/-) buttons**
  - Select an item or adjust the value in the On-Screen Menu (p.24).
  - Pan the image in the Digital zoom + mode (p.39).
  - Adjust the volume level (Point ◀▶ buttons) (p.27).
- MENU button**  
Open or close the On-Screen Menu (p.24).
- FREEZE button**  
Freeze the picture on the screen (p.28).
- LASER button**
  - Operate the Laser pointer function. Laser beam is emitted while pressing this button for one minute. When using this laser pointer for more than one minute, release this button and press it again (p.14).
  - Display the Pointer on the screen (p.14).
- PAGE ▲▼ buttons**  
Scroll back and forth the pages on the screen when giving a presentation. To use these buttons, connect the projector and your computer with a USB cable (pp.11, 19)
- LAMP CONTROL button**  
Select a lamp mode (pp.28, 53).
- D.ZOOM ▲▼ buttons**  
Zoom in and out the images (pp.28, 39).
- RESET/ON/ALL-OFF switch**  
When using the remote control, set this switch to "ON." Set it to "ALL OFF" for power saving when it is not used. Slide this switch to "RESET" to initialize the remote control code or switch the Spotlight and Pointer to the Laser pointer function (pp.14–15).
- IMAGE button**  
Select an image mode (pp.29, 36, 43).
- MUTE button**  
Mute the sound (p.27).
- P-TIMER button**  
Operate the P-timer function (p.29).
- NO SHOW button**  
Temporarily turn off the image on the screen (p.29).
- R-CLICK button**  
Act as the right mouse button for wireless mouse operation (p.15).
- SELECT button**
  - Execute the selected item (p.24).
  - Expand or compress the image in the Digital zoom mode (p.39).
- PRESENTATION POINTER button**  
Move a pointer of the projector or a pointer for wireless mouse operation (pp.14–15).
- AUTO SET button**  
Correct vertical keystone distortion and adjust the PC display parameters (pp.26, 47).
- NETWORK button**  
Select the Network input or Memory viewer input. See the owner's manual "Network Set-up and Operation" and owner's manual of Memory viewer (optionally available).

## Laser Pointer Function

This remote control emits a laser beam from the laser light window. Press the LASER button to activate the laser pointer. The signal emission indicator lights red and the red laser beam is emitted. If the LASER button is pressed for more than one minute or if it is released, the laser light goes off.

The laser emitted is a Class II laser. Do not look into the laser light window or point the laser beam at yourself or other people. The following is the caution label for the laser beam.

**CAUTION:** Use of controls, adjustments or performance of procedures other than those specified herein may result in hazardous radiation exposure. Never look directly into the laser light window while a laser is emitted, otherwise eye damage may result.

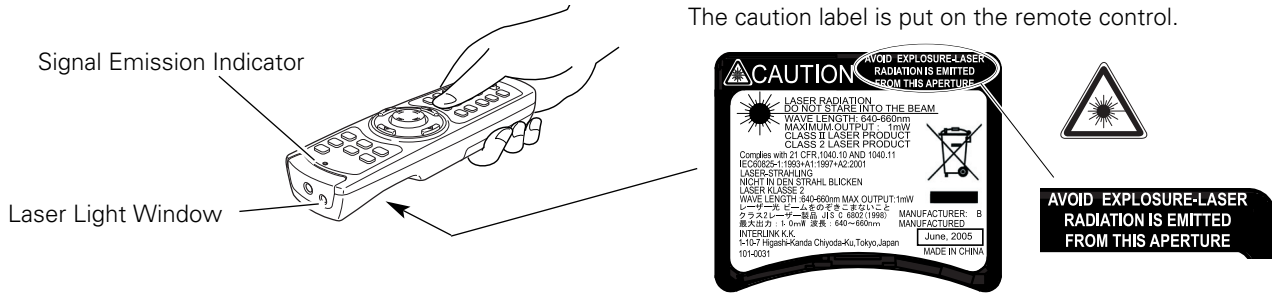

## Pointer Function

You can move the Spotlight or Pointer of the projector with the remote control to emphasize a part of the projected image.

- 1** Press and hold the MENU and NO SHOW buttons for more than 10 seconds to activate the Pointer function. (The Laser pointer has switched to the Pointer function.)
- 2** Press the LASER button on the remote control pointing toward the projector. The Spotlight or Pointer is displayed on the screen with the LASER button lighting green. Then move the Spotlight or Pointer with the PRESENTATION POINTER button. If the LASER button does not light green and continues to emit a laser beam, try the abovementioned procedure until the LASER button lights green.
- 3** To clear the Spotlight or Pointer out the screen, press the LASER button pointing toward the projector and see if the LASER button lighting is turned off. To switch to the Laser pointer again, press and hold the NO SHOW and MENU buttons for more than 10 seconds or slide the RESET/ON/ALL-OFF switch to "RESET" and then to "ON". When you reset the Pointer function, the remote control code will be reset, as well.

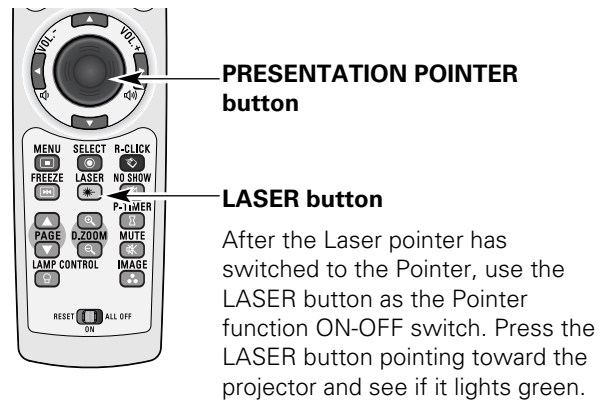
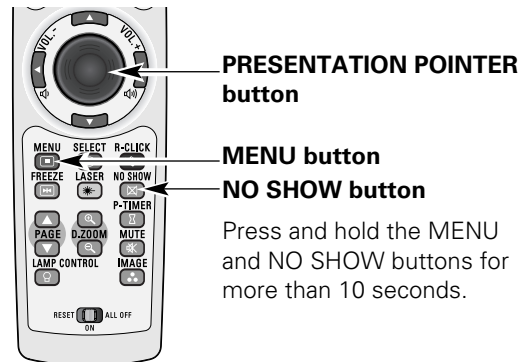

### Spotlight

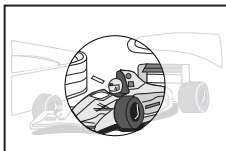

### Pointer

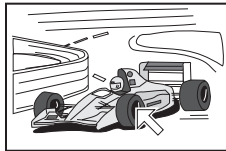

**✓Note:**

- You can choose the size of Spotlight (Large/Middle/Small) and the pattern of Pointer (Arrow/Finger/Dot) in the Setting Menu. See "Pointer" on page 53.

### Wireless Mouse Operation

The remote control can be used as a wireless mouse for your computer.

- 1 Before operating the wireless mouse, connect your computer and the projector with a USB cable (not supplied). See "Connecting to a Computer" on page 19. When the Pointer function is used, the wireless mouse is not available.
- 2 When a USB cable is connected to the computer and the projector, turn on the projector first, then the computer. If you turn on the computer first, the wireless mouse function may not operate correctly.



**PRESENTATION POINTER button**

Move the pointer on the screen with this button.

**R-CLICK button**

Acts as right (click) mouse button while the projector and a computer are connected with a USB cable.

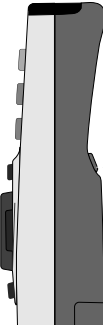

**L-CLICK button**

Acts as left (click) mouse button while the projector and a computer are connected with a USB cable.

### Remote Control Code

The eight different remote control codes (Code 1–Code 8) are assigned to this projector. Switching the remote control codes prevents interference from other remote controls when several projectors or video equipment next to each other are operated at the same time. Change the remote control code for the projector first before changing that for the remote control. See "Remote control" in the Setting Menu on page 53.

- 1 Press and hold the MENU and IMAGE buttons for more than five seconds to switch between the codes. The code switches sequentially for one pressing the IMAGE button. See the list below.
- 2 To initialize the remote control code, slide the RESET/ON/ALL-OFF switch to "RESET," and then to "ON." The initial code is set to Code 1.

Remote Control Code	Number of Times Pressing IMAGE Button
Code 1	1
Code 2	2
Code 3	3
Code 4	4
Code 5	5
Code 6	6
Code 7	7
Code 8	8



While pressing the MENU button, press the IMAGE button number of times corresponding to the remote control code.

**MENU button**

**IMAGE button**

### Remote Control Battery Installation

- 1** Open the battery compartment lid.

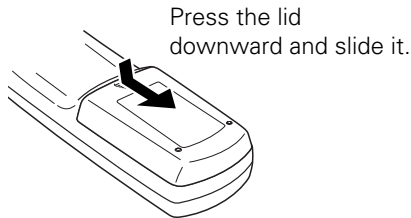

- 2** Install new batteries into the compartment.

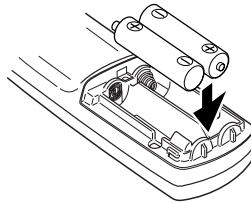

#### Two AAA size batteries

For correct polarity (+ and -), be sure battery terminals are in contact with pins in compartment.

- 3** Replace the compartment lid.

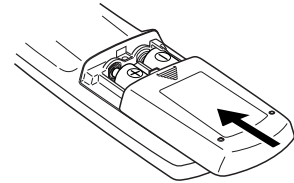

To insure safe operation, please observe the following precautions :

- Use two (2) AAA or LR03 type alkaline batteries.
- Always replace batteries in sets.
- Do not use a new battery with a used battery.
- Avoid contact with water or liquid.
- Do not expose the remote control to moisture or heat.
- Do not drop the remote control.
- If the battery has leaked on the remote control, carefully wipe the case clean and install new batteries.
- Risk of an explosion if battery is replaced by an incorrect type.
- Dispose of used batteries according to the instructions.

### Remote Control Operating Range

Point the remote control toward the projector (Infrared Remote Receiver) when pressing the buttons. Maximum operating range for the remote control is about 16.4' (5 m) and 60 degrees in front of the projector.

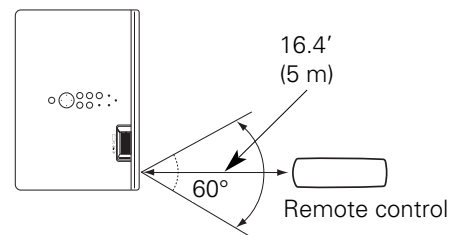

### Adjustable Feet

Projection angle can be adjusted up to approx. 9.0 degrees with the adjustable feet.

Lift the front of the projector and pull the feet lock latches on both side of the projector upward.

Release the feet lock latches to lock the adjustable feet and rotate the adjustable feet to a proper height, and tilt.

Keystone distortion can be adjusted automatically with the Auto setup function or manually by using the remote control or the menu operation (see pages 26, 47–48).

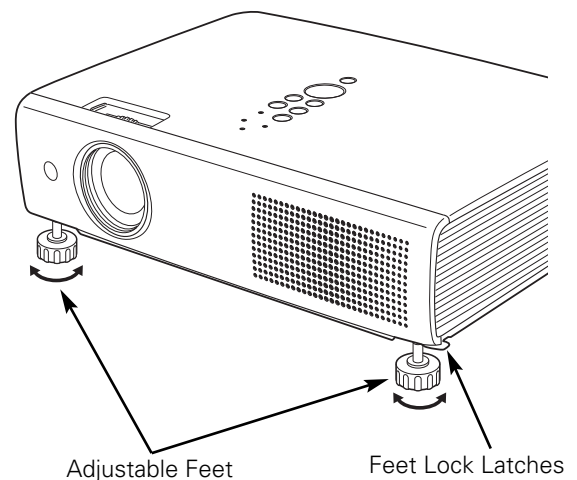



# Installation

## Positioning the Projector

For projector positioning, see the figures below. The projector should be set perpendicularly to the plane of the screen.

**✓Notes:**

- The brightness in the room has a great influence on picture quality. It is recommended to limit ambient lighting in order to obtain the best image.
- All measurements are approximate and may vary from the actual sizes.

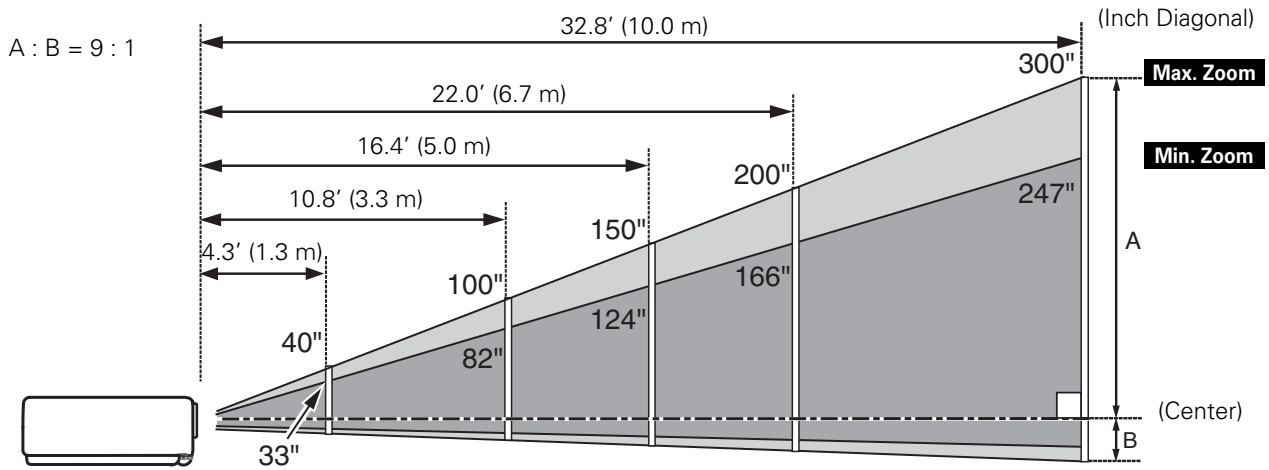

Screen Size (W x H) mm	33"	40"	100"	150"	200"	300"
4 : 3 aspect ratio	671 x 503	813 x 610	2032 x 1524	3048 x 2286	4064 x 3048	6096 x 4572
Zoom (min)	4.3' (1.3 m)	5.2' (1.6m)	13.1' (4.0 m)	20.0' (6.1 m)	26.6' (8.1 m)	—
Zoom (max)	—	4.3' (1.3m)	10.8' (3.3 m)	16.4' (5.0 m)	22.0' (6.7 m)	32.8' (10.0 m)

## Connecting the AC Power Cord

This projector uses nominal input voltages of 100–120 V or 200–240 V AC and it automatically selects the correct input voltage. It is designed to work with single-phase power systems having a grounded neutral conductor. To reduce the risk of electrical shock, do not plug into any other type of power system.

If you are not sure of the type of power being supplied, consult your authorized dealer or service station.

Connect the projector with all peripheral equipment before turning the projector on.

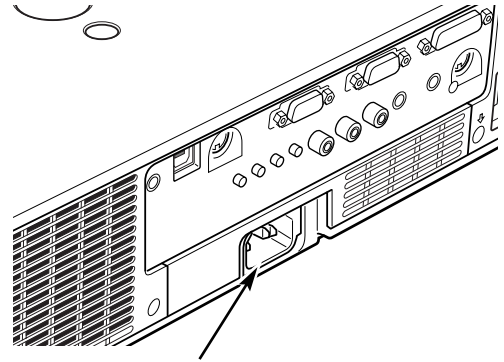

Connect the AC power cord (supplied) to the projector.

The AC outlet must be near this equipment and must be easily accessible.



### CAUTION

For safety, unplug the AC power cord when the projector is not in use. When the projector is connected to an outlet with the AC power cord, it is in stand-by mode and consumes a little electric power.

### NOTE ON THE POWER CORD

AC power cord must meet the requirements of the country where you use the projector. Confirm the AC plug type with the chart below and proper AC power cord must be used. If supplied the AC power cord does not match your AC outlet, contact your sales dealer.

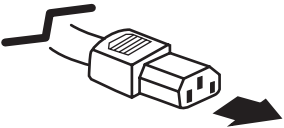
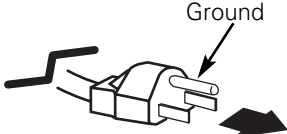
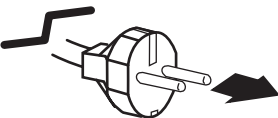
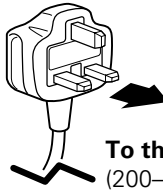
Projector side	AC outlet side		
 <p>To power cord connector on your projector.</p>	<p><b>For the U.S.A. and Canada</b></p>  <p>To the AC outlet. (120 V AC)</p>	<p><b>For Continental Europe</b></p>  <p>To the AC outlet. (200–240 V AC)</p>	<p><b>For the U.K.</b></p>  <p>To the AC outlet. (200–240 V AC)</p>

## Connecting to a Computer

### Cables used for connection

- VGA Cable (Mini D-sub 15 pin)\*
- DVI-I/VGA Cable
- USB Cable
- Audio Cables

(\*One cable is supplied; other cables are not supplied with the projector.)

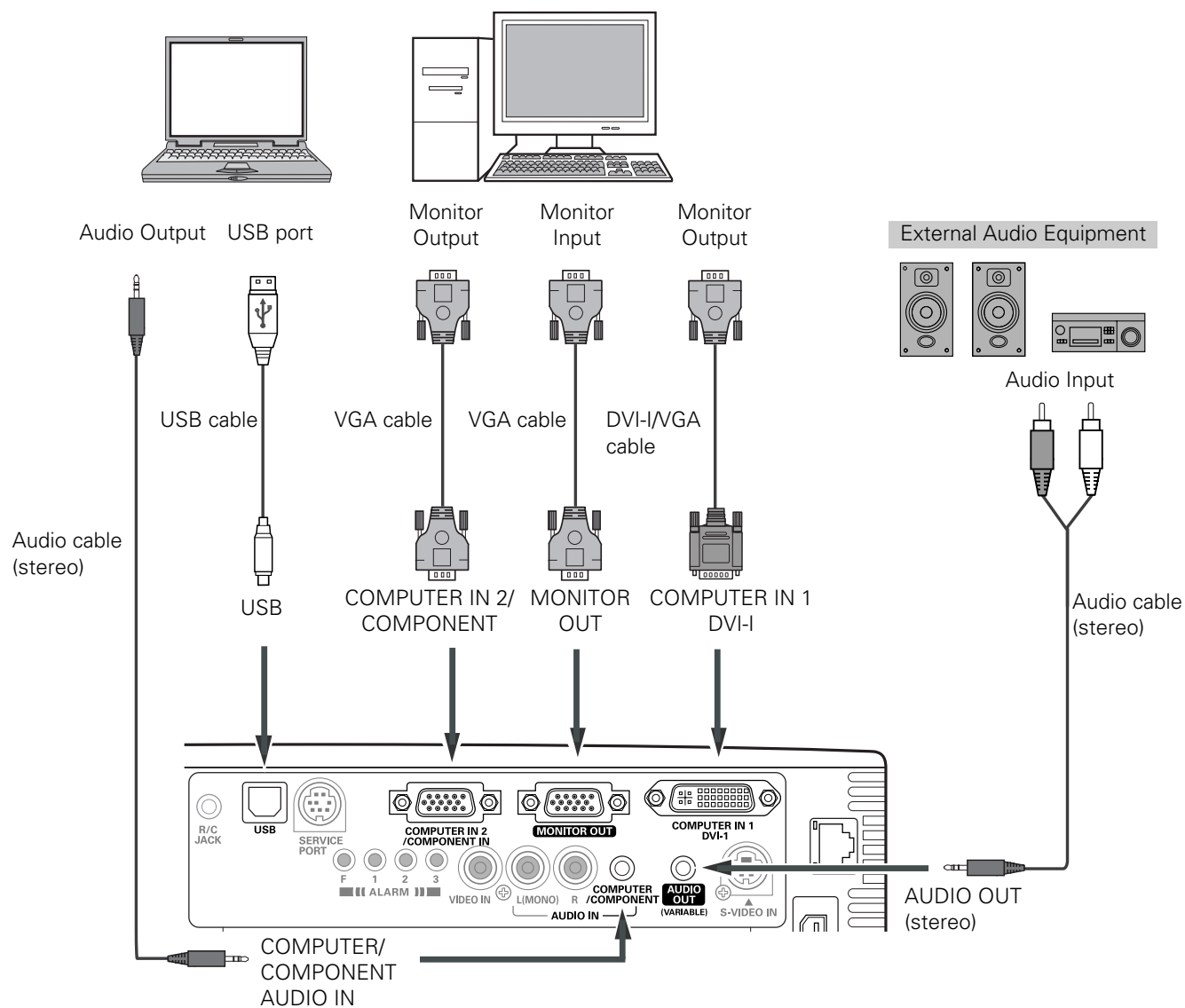

### Notes:

- Input sound to the COMPUTER/COMPONENT AUDIO IN terminal when using the COMPUTER IN 1/DVI-I and the COMPUTER IN 2/COMPONENT IN terminal as input.
- When connecting the AUDIO OUT to external audio equipment, the projector's built-in speaker is disconnected.
- USB cable connection is needed when operating the computer with the remote control or using the PAGE ▲▼ buttons on the remote control.

 Unplug the power cords of both the projector and external equipment from the AC outlet before connecting cables.

## Connecting to Video Equipment

### Cables used for connection

- Video and Audio Cable (RCA x 3)
  - S-VIDEO Cable
  - Audio Cable
- (Cables are not supplied with the projector.)

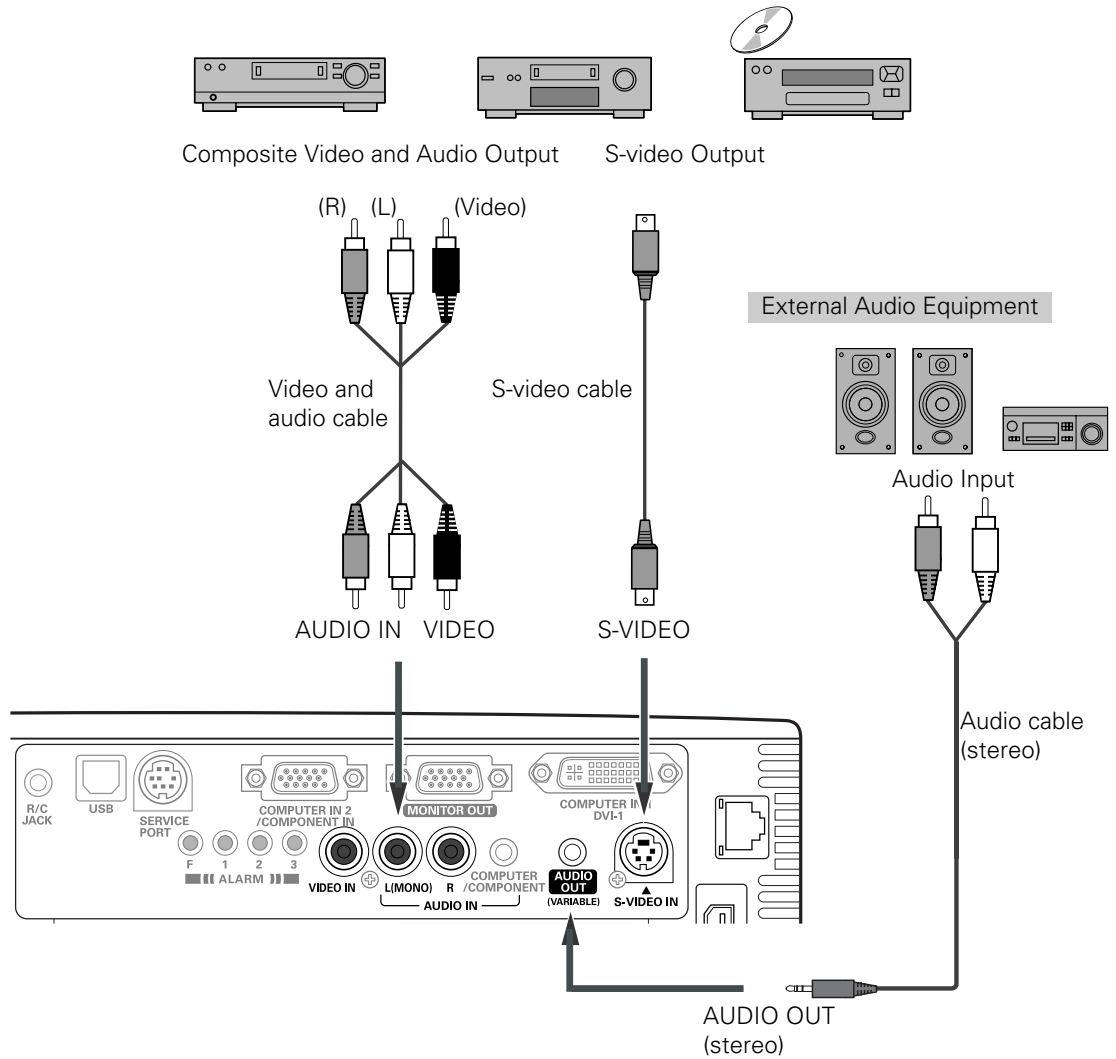

### Notes:

- When connecting the AUDIO OUT to external audio equipment, the projector's built-in speaker is disconnected.
- The S-VIDEO jack connection overrides the VIDEO jack connection when selecting AUTO in the Input Menu (p.40).



Unplug the power cords of both the projector and external equipment from the AC outlet before connecting cables.

## Connecting to Component Video Equipment

### Cables used for connection

- Audio Cables
- Scart-VGA Cable
- Component Cable
- Component-VGA Cable

(Cables are not supplied with the projector.)

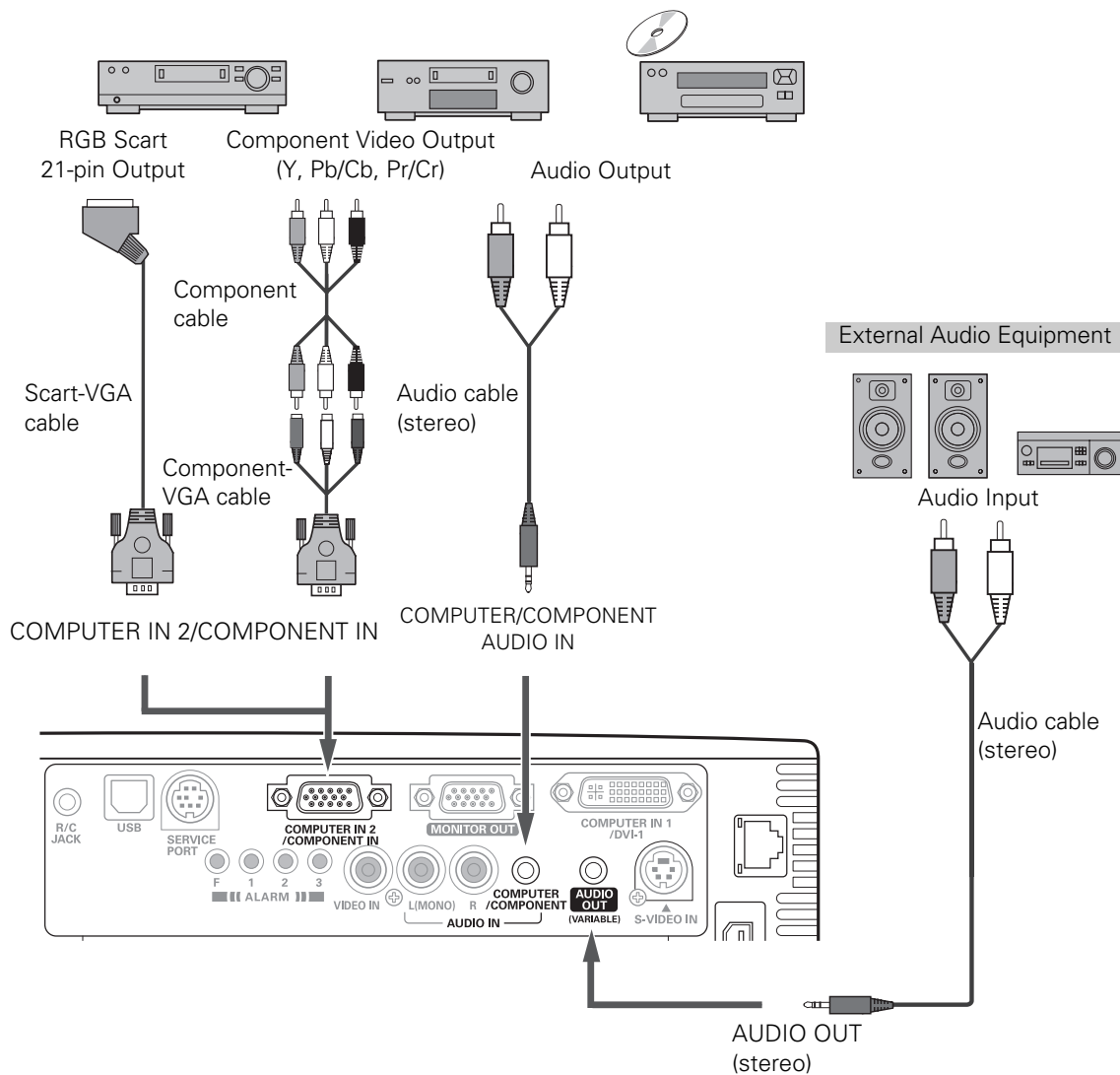

### Notes:

- When connecting the AUDIO OUT to external audio equipment, the projector's built-in speaker is disconnected.
- See page 75 for ordering optional cables.
- RGB Scart signal cannot be output from the MONITOR OUT terminal.



Unplug the power cords of both the projector and external equipment from the AC outlet before connecting cables.

# Basic Operation

## Turning On the Projector

- 1 Complete peripheral connections (with a computer, VCR, etc.) before turning on the projector.
- 2 Connect the projector's AC power cord into an AC outlet. The POWER indicator lights red. Open the slide shutter by sliding the slide shutter lever (see pages 10, 64).
- 3 Press the ON/STAND-BY button on the top control or the remote control. The POWER indicator lights green and the cooling fans start to operate. The preparation display appears on the screen and the count down starts.
- 4 After the countdown, the input source that was selected the last time and the lamp control status icon (see page 53) appear on the screen.

If the projector is locked with a PIN code, PIN code input dialog box will appear. Enter the PIN code as instructed below.

### Enter a PIN code

Use the Point ▲▼ buttons to enter a number. Press the Point ► button to fix the number and move the red frame pointer to the next box. The number changes to "\*" If you fixed an incorrect number, use the Point ◀ button to move the pointer to the number you want to correct, and then enter the correct number.

Repeat this step to complete entering a four-digit number.

After entering the four-digit number, move the pointer to "Set." Press the SELECT button so that you can start to operate the projector.

If you entered an incorrect PIN code, "PIN code" and the number (\*\*\*\*) will turn red for a moment. Enter the correct PIN code all over again.

### What is PIN code?

PIN (Personal Identification Number) code is a security code that allows the person who knows it to operate the projector. Setting a PIN code prevents unauthorized use of the projector.

A PIN code consists of a four-digit number. Refer to the PIN code lock function in the Setting Menu on pages 54–55 for locking operation of the projector with your PIN code.



#### CAUTION ON HANDLING PIN CODE

If you forget your PIN code, the projector can no longer be started. Take a special care in setting a new PIN code; write down the number in a column on page 78 of this manual and keep it at hand. Should the PIN code be missing or forgotten, consult your dealer or service center.



The preparation display will disappear after 30 seconds.

### Selected Input Source and Lamp Control



(See page 53 for Lamp control status.)

#### ✓ Note:

- The Filter warning and Lamp replacement icons may appear on the screen depending on the usage state of the projector.

### PIN Code Input Dialog Box

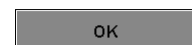
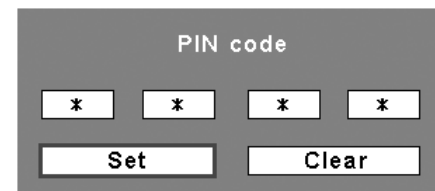

After the OK icon disappears, you can operate the projector.

#### ✓ Notes:

- When the Logo select function is set to "Off," the logo will not be shown on the screen (p.50).
- When the "Countdown off" or "Off" is selected in the Display function, the countdown will not be shown on the screen (p.48).
- During the countdown period, all operations are invalid.
- If the correct PIN code number is not entered within three minutes after the PIN code dialog box appeared, the projector will be turned off automatically.
- The "1234" is set as the initial PIN code at the factory.
- When the Input Search function is set to "On1" or "On2", the input signal will be searched automatically (p.51).

## Turning Off the Projector

- 1 Press the ON/STAND-BY button on the top control or on the remote control, and "Power off?" appears on the screen.
- 2 Press the ON/STAND-BY button again to turn off the projector. The POWER indicator starts to blink red, and the cooling fans keep running. (You can select the level of fans' quietness and speed. See "Fan" on page 56.) At this time, you can unplug the AC power cord even if the fans are still running.
- 3 When the projector has cooled down enough, the POWER indicator stops blinking and you can turn on the projector. After it is cooled down completely, unplug the AC power cord.

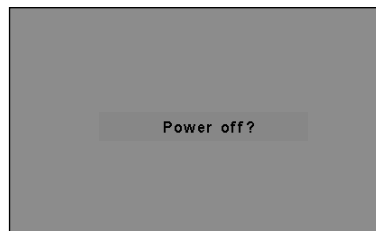

"Power off?" disappears after 4 seconds.



TO MAINTAIN THE LIFE OF THE LAMP, ONCE YOU TURN THE PROJECTOR ON, WAIT AT LEAST FIVE MINUTES BEFORE TURNING IT OFF.

### ✓Notes:

- When the On start function is set to "On," the projector will be turned on automatically by connecting the AC power cord to an AC outlet (p.53).
- DO NOT OPERATE THE PROJECTOR CONTINUOUSLY WITHOUT REST. CONTINUOUS USE MAY RESULT IN SHORTENING THE LAMP LIFE. TURN OFF THE PROJECTOR AND LET STAND FOR ABOUT AN HOUR IN EVERY 24 HOURS.
- The running speed of cooling fans is changed according to the temperature inside the projector.
- Do not put the projector in a case before the projector is cooled enough.
- If the WARNING indicator blinks or lights red, see "Warning Indicator" on page 62.
- While the POWER indicator is blinking, the lamp is being cooled down and the projector cannot be turned on. Wait until the POWER indicator stops blinking to turn on the projector again.
- The fan rotation will terminate directly if the AC power cord is unplugged immediately after the projector is turned off.
- The projector can be turned on after the POWER indicator turns red. The waiting time to restart will be shortened when the normal power-off processing for fan cooling is completed, compared with the time the AC power cord is immediately unplugged after the power-off.

## How to Operate the On-Screen Menu

The projector can be adjusted or set via the On-Screen Menu. For each adjustment and setting procedure, refer to the respective sections in this manual.

- 1 Press the MENU button on the top control or the remote control to display the On-Screen Menu.
- 2 Use the Point ◀▶ buttons to select a Menu icon. Use the Point ▲▼ buttons to select an item in the selected menu.
- 3 Press the SELECT button to show the item data. Use the Point ◀▶ buttons to adjust the values.

To close the On-Screen Menu, press the MENU button again.

**✓Note:**

- The selected item is not active until the SELECT button is pressed.

### Top Control

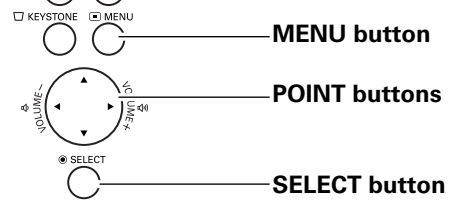

### Remote Control

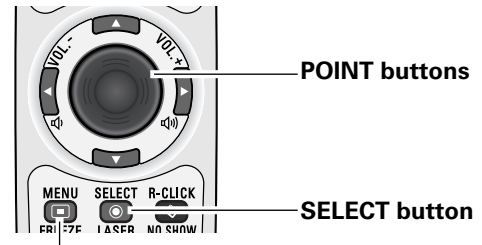

### MENU button

### On-Screen Menu

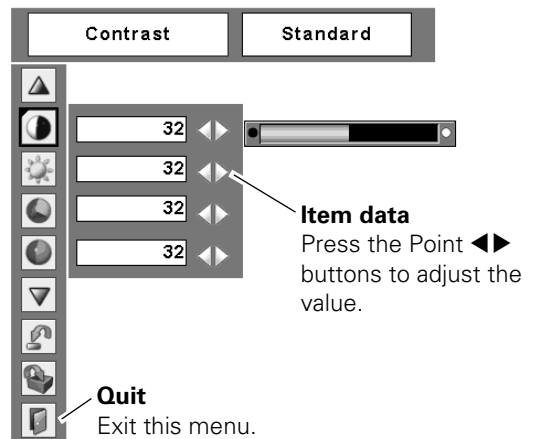
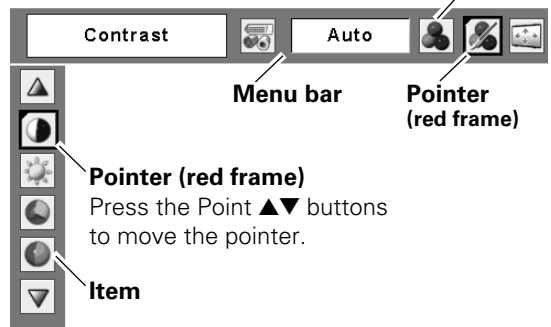



## Menu Bar

For detailed functions of each menu, see “Menu Tree” on pages 69–70.

### For computer source

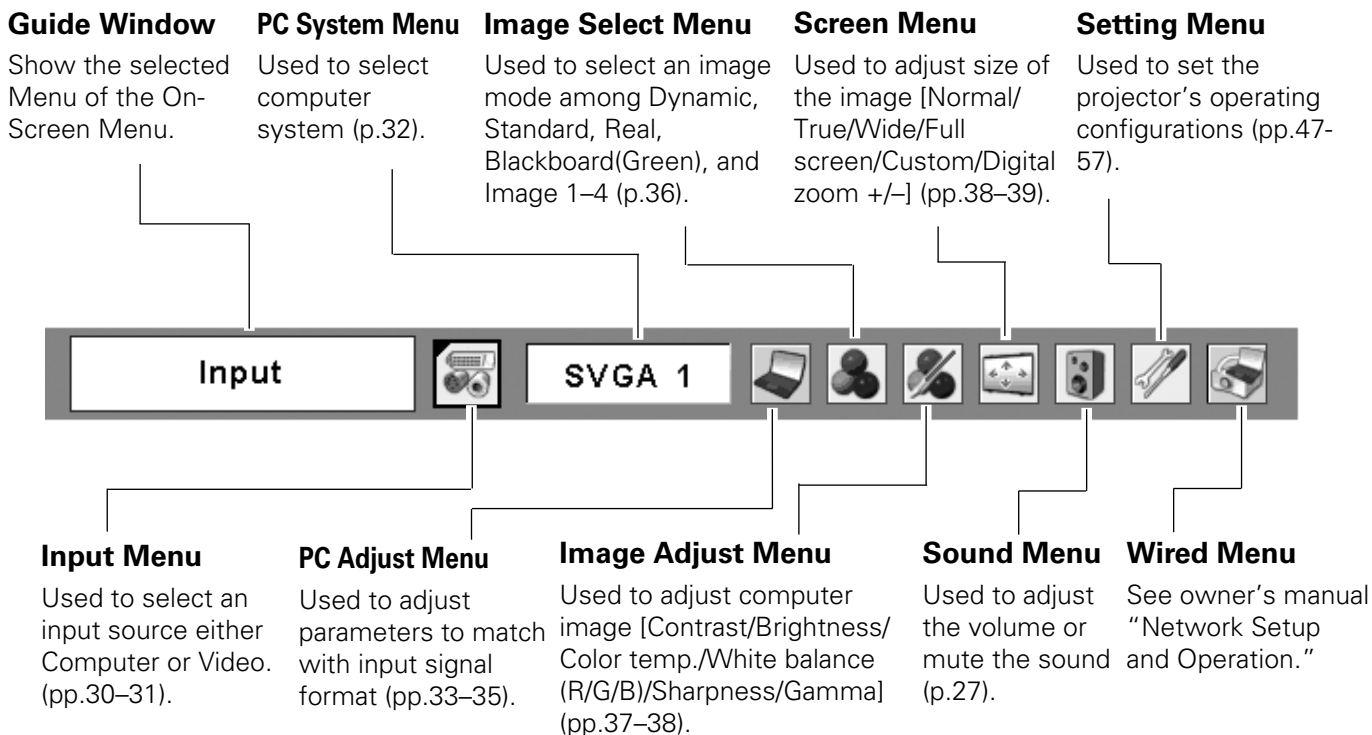

### For video source

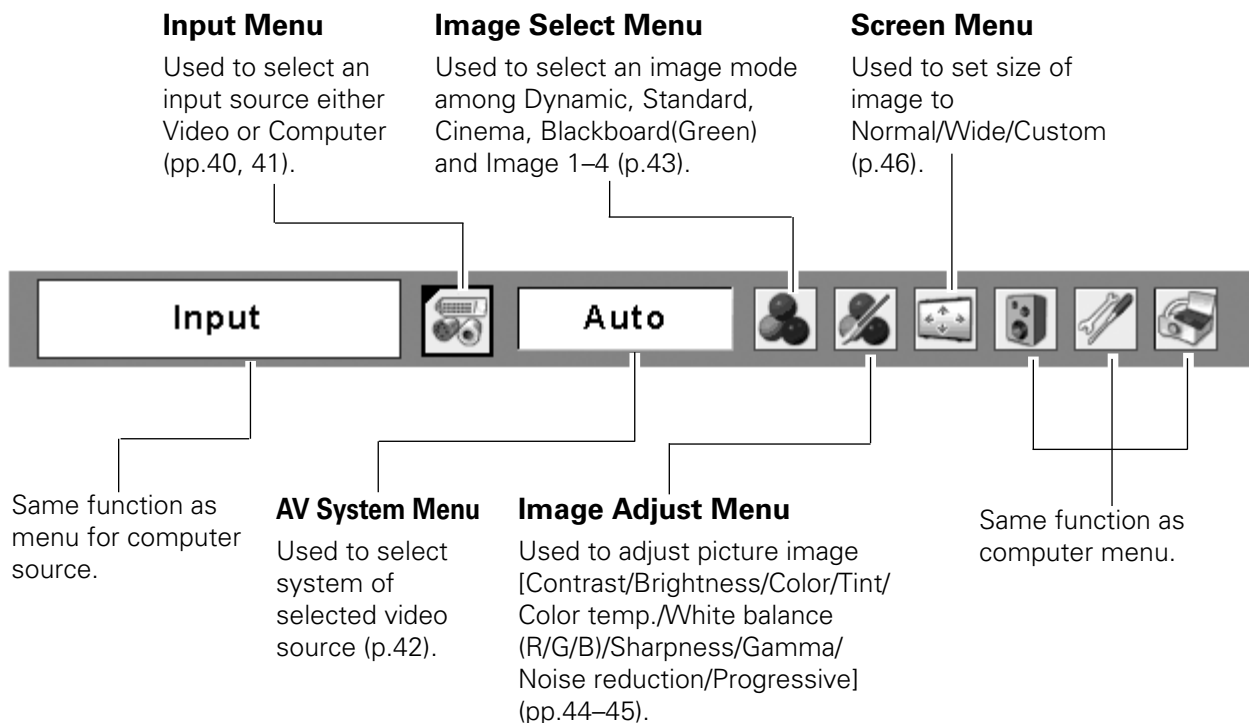

## Zoom and Focus Adjustment

Rotate the Zoom Ring to zoom in and out.  
 Rotate the Focus Ring to adjust the focus of the image.

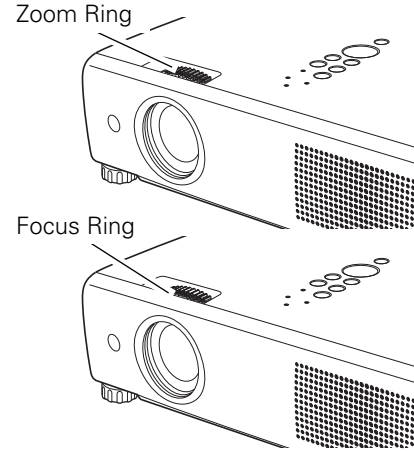

## Auto Setup Function

Auto setup function is provided to automatically correct Keystone distortion according to the projector's tilt and adjust the computer display parameters (Fine sync, Total dots, and Picture position) by just pressing the AUTO SETUP button on the top control or the AUTO SET button on the remote control. The operational setup for the Auto setup can be changed in the Setting menu. Refer to page 47 for the setting of the Auto setup function.

**Notes:**

- Auto Keystone corrects vertical distortion only; it does not correct horizontal distortion.
- Auto Keystone cannot work when Ceiling feature is set to "On" in the Setting menu (p.51).
- Perfect correction of the image distortion cannot be ensured with the Auto setup function. If the distortion cannot be corrected properly by pressing the AUTO SETUP/AUTO SET button, adjust manually by pressing the KEYSTONE button on the top control or on the remote control or selecting Keystone in the Setting menu (p.48).

### Top Control

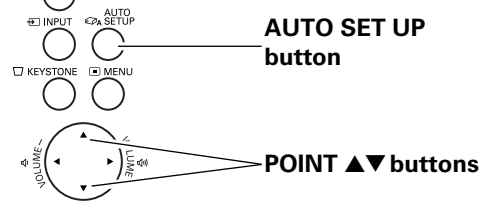

### Remote Control

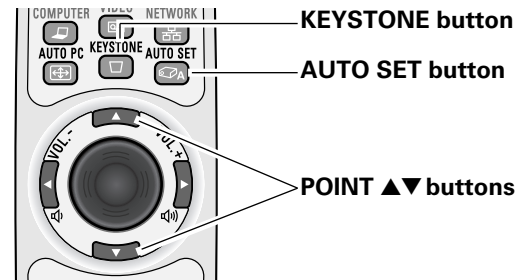

## Keystone Correction

If a projected picture still has keystone distortion after pressing the AUTO SETUP button on the top control or the AUTO SET button on the remote control, correct the image manually as follows:

Press the KEYSTONE button on the top control or on the remote control. The Keystone dialog box appears. Use the Point ▲▼ buttons to correct keystone distortion. The keystone adjustment can be stored (see page 48).

Reduce the upper width with the Point ▲ button.

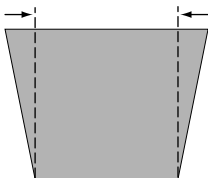

Reduce the lower width with the Point ▼ button.

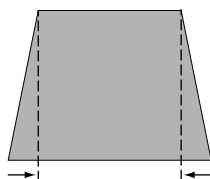

- The white arrows indicate that there is no correction.
- A red arrow indicates the direction of correction.
- An arrow disappears at the maximum correction.
- If you press the KEYSTONE button on the top control or on the remote control once more while the keystone dialog box is being displayed, the keystone adjustment will be canceled.
- The adjustable range can be limited depending on the input signal.

## Sound Adjustment

### Direct Operation

#### Volume

Press the VOLUME+/- buttons on the top control or on the remote control to adjust the volume. The volume dialog box appears on the screen for a few seconds.

#### Mute

Press the MUTE button on the remote control to temporarily turn off the sound. To turn the sound back on, press the MUTE button again or press the VOLUME +/- buttons. The Mute function is also effective for the AUDIO OUT jack.

### Menu Operation

- 1 Press the MENU button to display the On-Screen Menu. Use the Point ◀▶ buttons to move the red frame pointer to the Sound Menu icon.
- 2 Use the Point ▲▼ buttons to move the red frame pointer to the desired item, and then press the SELECT button.

#### Volume

Press the Point ▶ button to turn up the volume; press the Point ◀ button to turn down the volume.

#### Mute

Press the Point ◀▶ buttons to switch the mute function On/Off. When the sound is turned off, "On" is displayed. Press the Point ◀▶ buttons again to turn the sound back on.

#### Top Control

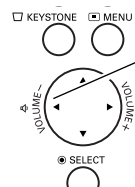

VOLUME+/- buttons

#### Remote Control



VOL - button

VOL + button

MUTE button

#### Volume Dialog Box

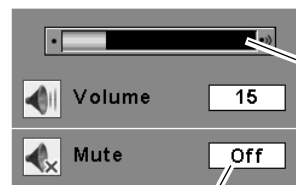

Approximate level of the volume.

Press the MUTE button to set the Mute function On or Off. The dialog box disappears after 4 seconds.

#### Sound Menu

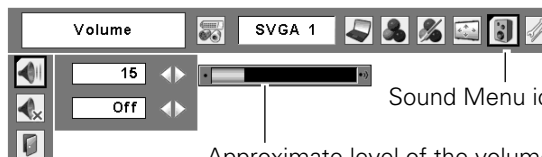

Sound Menu icon

Approximate level of the volume.

Exit the Sound Menu.

## Remote Control Operation

Using the remote control for some frequently used operations is advisable. Just pressing one of the buttons enables you to make the desired operation quickly without calling up the On-Screen Menu.

### COMPUTER/VIDEO/NETWORK button

Press the COMPUTER, VIDEO, or NETWORK button on the remote control to select the input source. For more detail, see pages 30–31, 40–41.

Refer to the owner's manual "Network Set-up and Operation" for details about the network input.

### FREEZE button

Press the FREEZE button on the remote control to freeze the picture on the screen. To cancel the Freeze function, press the FREEZE button again or press any other button.

### AUTO PC button

Press the AUTO PC button on the remote control to operate the Auto PC Adj. function. The computer screen adjustment can be done easily by pressing this button. See page 33 for details.

### D.ZOOM buttons

Press the D.ZOOM buttons on the remote control to enter to the Digital zoom +/- mode. See page 39 for details.

### LAMP CONTROL button

Press the LAMP CONTROL button on the remote control to select the lamp mode for changing the brightness on the screen.

- 🔆 Auto ..... The brightness according to the input signal (between High and Eco mode).
- 🔆 High ..... Brighter than the Normal mode.
- 💡 Normal ..... Normal brightness
- 💡 Eco ..... Lower brightness reduces the lamp power consumption and extends the lamp life.

### Remote Control

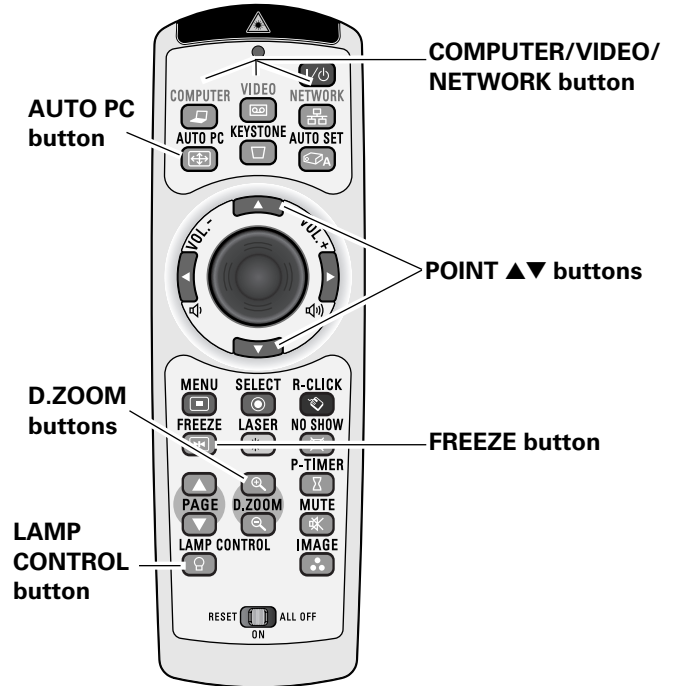

✓ **Note:**

- See the next page for the description of other buttons.

### NO SHOW button

Press the NO SHOW button on the remote control to black out the image. To restore to normal, press the NO SHOW button again or press any other button. When a projected image is captured and set as "User" in the Logo selection (see page 49), the screen changes each time you press the NO SHOW button as follows.

black out → the captured image → normal → .....

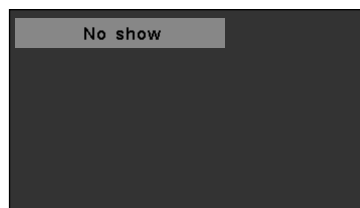

"No show" disappears after 4 seconds.

### P-TIMER button

Press the P-TIMER button on the remote control. The P-Timer display "00:00" appears on the screen and the countdown starts (00:00–59:59).

To stop the countdown, press the P-TIMER button. To cancel the P-Timer function, press the P-TIMER button again.



P-Timer display

### IMAGE button

Press the IMAGE button on the remote control to select a desired image mode of the screen. For more detail, see pages 36, 43.

### Remote Control



NO SHOW button

P-TIMER button

IMAGE button

#### ✓ Note:

- See the previous page for the description of other buttons.

# Computer Input

## Input Source Selection (RGB: Computer 1 (Analog)/Computer 2 )

### Direct Operation

Choose either Computer 1 (Analog) or Computer 2 by pressing the INPUT button on the top control or press the COMPUTER button on the remote control. Before using these buttons, correct input source should be selected through Menu operation as described below.

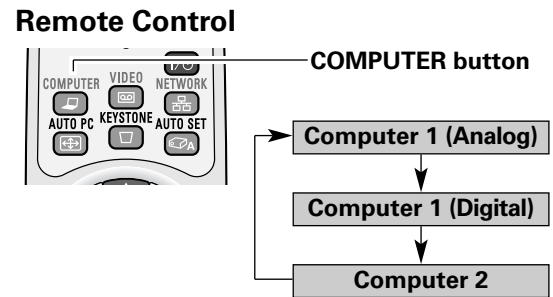
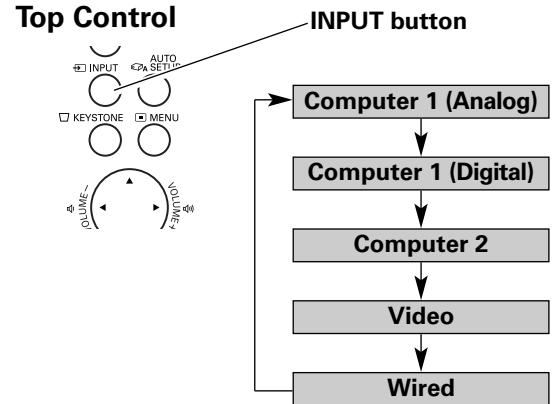

### Menu Operation

- 1 Press the MENU button to display the On-Screen Menu. Use the Point ◀▶ buttons to move the red frame pointer to the Input Menu icon.
- 2 Use the Point ▲▼ buttons to move the red arrow pointer to either Computer 1 (Analog) or Computer 2, and then press the SELECT button.
- 3 When selecting Computer 1 (Analog), RGB input source will be selected directly. When selecting Computer 2, the Source Select Menu appears. Move the pointer to RGB and then press the SELECT button.

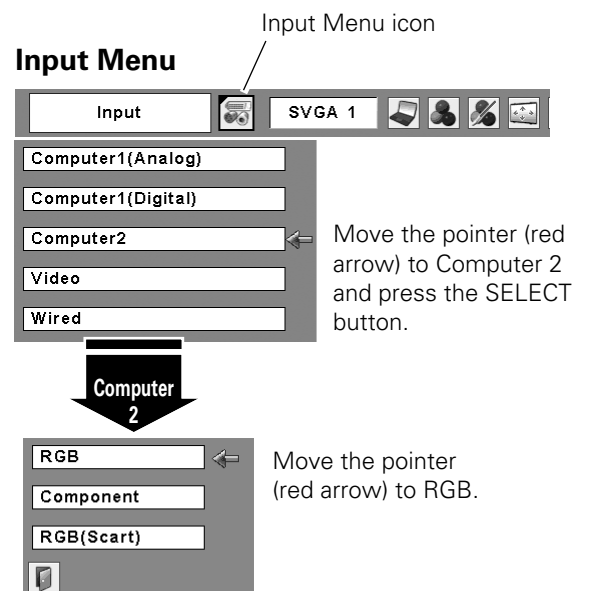
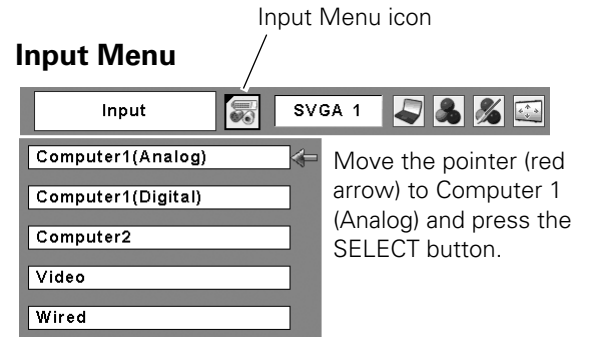

#### ✓Notes:

- Wired, Wireless, and Memory viewer are for the Network function. See owner's manual "Network Set-up and Operation" and owner's manual of Memory viewer (optionally available).
- When the Input Search function is set to "On1" or "On2", the input signal will be searched automatically (p.51).

## Input Source Selection (RGB (PC digital), RGB (AV HDCP))

### Direct Operation

Choose Computer 1 (Digital) by pressing the INPUT button on the top control or press the COMPUTER button on the remote control.

Before using these buttons, correct input source should be selected through Menu operation as described below.

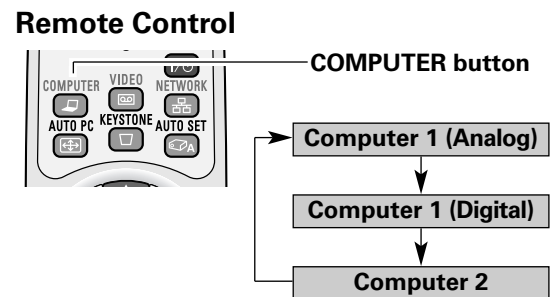
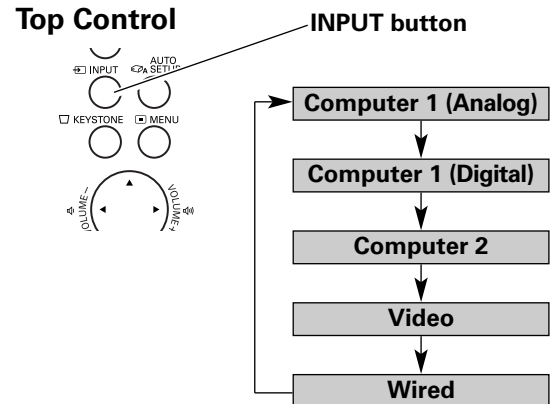

### Menu Operation

- 1** Press the MENU button to display the On-Screen Menu. Use the Point ◀▶ buttons to move the red frame pointer to the Input Menu icon.
- 2** Use the Point ▲▼ buttons to move the red arrow pointer to Computer 1 (Digital), and then press the SELECT button.
- 3** After the Source Select Menu appeared for Computer 1 (Digital), move the pointer to RGB (PC digital) or RGB (AV HDCP), and then press the SELECT button.

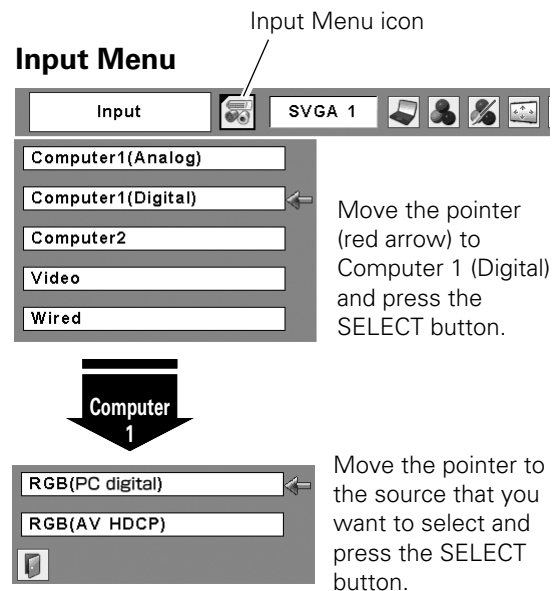

#### ✓Notes:

- HDCP (High-bandwidth Digital Content Protection) is a system for protecting digital entertainment content delivered by DVI (Digital Visual Interface) from being copied. The specification of HDCP is decided and controlled by Digital Content Protection, LLC. Should the specification be changed, this projector may not display the digital content protected by HDCP.
- Wired, Wireless, Memory viewer are for the Network function. See owner's manual "Network Set-up and Operation" and owner's manual of Memory viewer (optionally available).
- When the Input Search function is set to "On1" or "On2", the input signal will be searched automatically (p.51).

## Computer System Selection

This projector automatically tunes to various types of computers based on VGA, SVGA, XGA, SXGA, WXGA, or UXGA with its Multi-scan system and Auto PC Adjustment. If a computer is selected as a signal source, this projector automatically detects the signal format and tunes to project a proper image without any additional settings. (Signal formats provided in this projector are shown on pages 72–73.)

One of the following messages may appear when:

**Auto** The projector cannot recognize the connected signal conforming to the provided PC Systems. The “Auto” is displayed on the System Menu box and the Auto PC Adjustment function works to display proper images. If the image is not projected properly, a manual adjustment is required (pp.34–35).

**-----** There is no signal input from the computer. Check the connection between your computer and the projector. (See “Troubleshooting” on page 67.)

**Mode 1** The preset system is manually adjusted in the PC Adjust Menu. The adjusted data can be stored in Mode 1–5 (pp.34–35).

**SVGA 1** PC Systems provided in this projector is chosen. The projector chooses a proper system provided in the projector and displays it.

\*Mode 1 and SVGA 1 are examples.

### PC System Menu

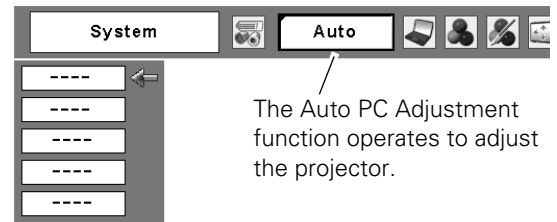

### Selecting Computer System Manually

PC system can also be selected manually.

- 1 Press the MENU button to display the On-Screen Menu. Use the Point ◀▶ buttons to move the red frame pointer to the PC System Menu icon.
- 2 Use the Point ▲▼ buttons to move the red arrow pointer to the desired system and then press the SELECT button.

### PC System Menu

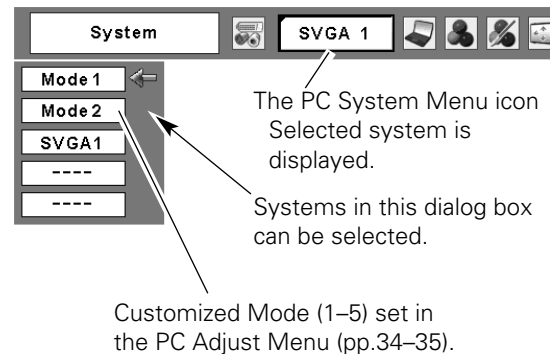



## Auto PC Adjustment

Auto PC Adjustment function is provided to automatically adjust Fine sync, Total dots, Horizontal and Vertical positions to conform to your computer.

### Direct Operation

The Auto PC adjustment function can be operated directly by pressing the AUTO PC button on the remote control.

### Remote Control

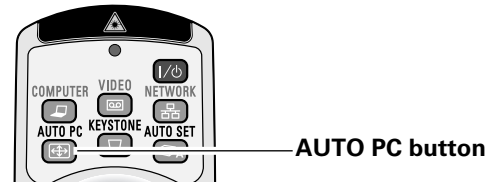

### Menu Operation

#### Auto PC Adj.

- 1 Press the MENU button to display the On-Screen Menu. Use the Point ◀▶ buttons to move the red frame pointer to the PC Adjust Menu icon.
- 2 Use the Point ▲▼ buttons to move the red frame pointer to Auto PC Adj. and then press the SELECT button twice.

#### To store adjustment parameters

The adjusted parameters from the Auto PC Adjustment can be stored in the projector. Once the parameters are stored, the setting can be done just by selecting a Mode (1–5) in the PC System Menu (see page 32). See also “Store” on page 35.

#### ✓Notes:

- Fine sync, Total dots, Horizontal and Vertical position of some computers cannot be fully adjusted with the Auto PC Adjustment function. When the image is not provided properly with this operation, manual adjustments are required (pp.34–35).
- The Auto PC Adjustment cannot be operated when 480i, 575i, 480p, 575p, 720p, 1035i, or 1080i is selected in the PC System Menu (p.32), or when the digital signal is coming from the DVI-I terminal.

### PC Adjust Menu

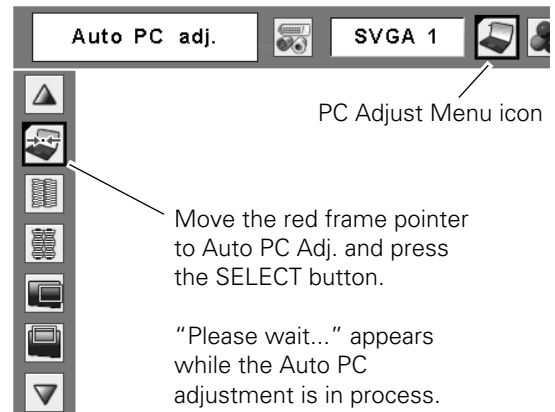

## Manual PC Adjustment

Some computers employ special signal formats which may not be tuned by Multi-scan system of this projector. Manual PC Adjustment enables you to precisely adjust several parameters to match those signal formats. The projector has five independent memory areas to store those parameters manually adjusted. It allows you to recall the setting for a specific computer.

- 1 Press the MENU button to display the On-Screen Menu. Use the Point ◀▶ buttons to move the red frame pointer to the PC Adjust Menu icon.
- 2 Use the Point ▲▼ buttons to move the red frame pointer to the desired item and then press the SELECT button to display the adjustment dialog box. Use the Point ◀▶ buttons to adjust the setting value.

### Fine sync

Use the Point ◀▶ buttons to adjust the value, eliminating a flicker from the image displayed (from 0 to 31).

### Total dots

Use the Point ◀▶ buttons to adjust the number of total dots in one horizontal period to match your PC image.

### Horizontal

Use the Point ◀▶ buttons to adjust the horizontal picture position.

### Vertical

Use the Point ◀▶ buttons to adjust the vertical picture position.

### Current mode

Press the SELECT button to show H-sync freq. and V-sync freq. of the connected computer.

### Clamp

Use the Point ◀▶ buttons to adjust the clamp level. When the image has dark bars, try this adjustment.

## PC Adjust Menu

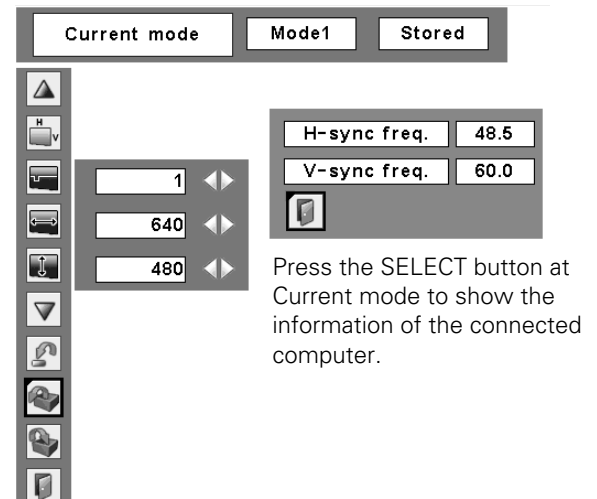
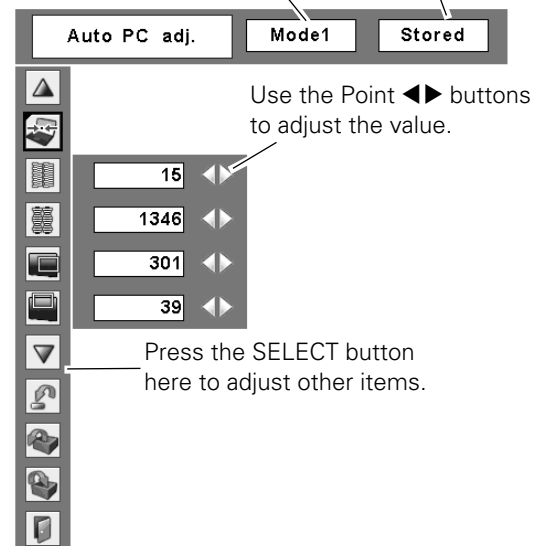
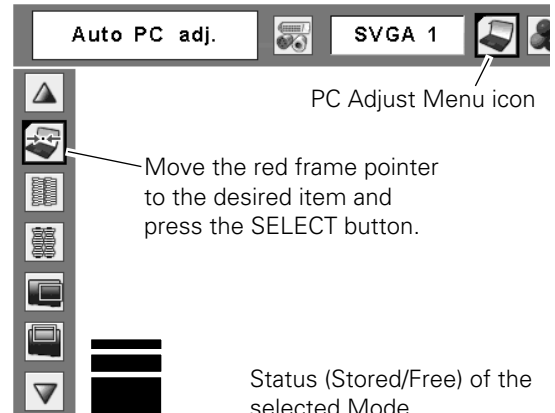

 **Display area H**

Use the Point ◀▶ buttons to adjust the horizontal area displayed by this projector.

 **Display area V**

Use the Point ◀▶ buttons to adjust the vertical area displayed by this projector.

 **Reset**

To reset the adjusted data, select Reset and press the SELECT button. A confirmation box appears and then select [Yes]. All adjustments will return to their previous figures.

 **Mode free**

To clear the stored data, select Mode free and then press the SELECT button. Move the red arrow pointer to the Mode that you want to clear and then press the SELECT button.

 **Store**

To store the adjusted data, select Store and then press the SELECT button. Move the red arrow pointer to one of the Modes 1 to 5 in which you want to store, and then press the SELECT button.

 **Quit**

Exit the PC Adjust Menu.

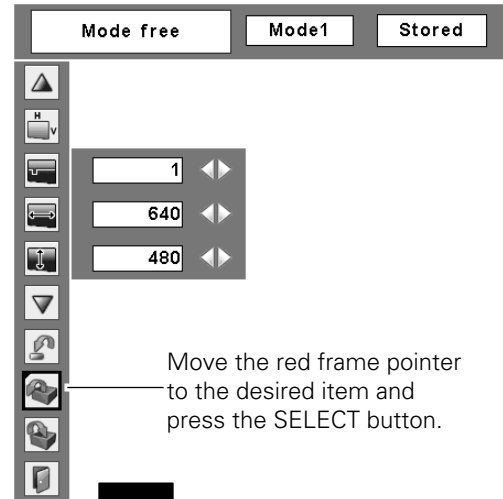

Move the red frame pointer to the desired item and press the SELECT button.



**To clear adjusted data** This Mode has stored parameters.

Where to free?

Mode1	Stored	800	142	34	1024	768
Mode2	Free	800	142	34	1024	768
Mode3	Free	800	142	34	1024	768
Mode4	Free	800	142	34	1024	768
Mode5	Free	800	142	34	1024	768

Vacant

Values of "Total dots," "Horizontal," "Vertical," "Display area H," and "Display area V."

**To store adjusted data**

Where to store?

Mode1	Stored	800	142	34	1024	768
Mode2	Free	800	142	34	1024	768
Mode3	Free	800	142	34	1024	768
Mode4	Free	800	142	34	1024	768
Mode5	Free	800	142	34	1024	768

Close this dialog box.

✓ **Notes:**

- Display area (H/V) cannot be selected when 480i, 575i, 480p, 575p, 720p, 1035i, or 1080i is selected in the PC System Menu (p.32).
- PC Adjust Menu cannot be selected when Computer I (Digital) is selected in the Input Menu (p.31).

## Image Mode Selection

### Direct Operation

Select the desired image mode from among Dynamic, Standard, Real, Blackboard (Green), Image 1, Image 2, Image 3, and Image 4 by pressing the IMAGE button on the remote control.

#### Dynamic

For viewing pictures in a bright room.

#### Standard

Normal picture mode preset on the projector.

#### Real

Picture mode with improved halftone for graphics.

#### Blackboard (Green)

For the image projected on a blackboard.  
This mode help enhance the image projected on a blackboard.  
This is mainly effective on a green colored board, not truly effective on a black colored board.

#### Image 1-4

For viewing with the user preset image mode in the Image Adjust Menu (see page 37-38). This Image memory is provided in each computer, component, and video input source.

### Menu Operation

- 1 Press the MENU button to display the On-Screen Menu. Use the Point ◀▶ buttons to move the red frame pointer to the Image Select Menu icon.
- 2 Use the Point ▲▼ buttons to move the red frame pointer to the desired image mode and then press the SELECT button.

#### Dynamic

For viewing pictures in a bright room.

#### Standard

Normal picture mode preset on the projector.

#### Real

Picture mode with improved halftone for graphics.

#### Blackboard(Green)

For the image projected on a blackboard. See above for further description.

#### Image 1-4

For viewing with the user preset image mode in the Image Adjust Menu (see page 37-38).

### Remote Control

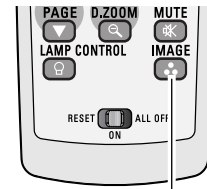
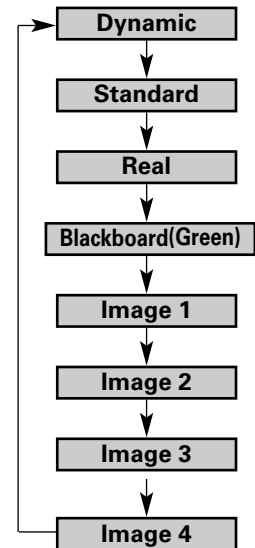
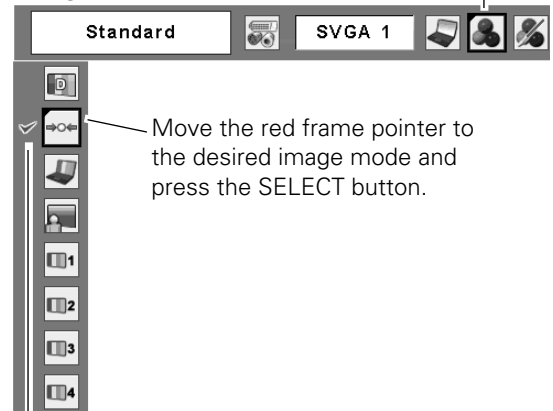

IMAGE button

### IMAGE button



### Image Select Menu



The selected image mode is check marked.

## Image Adjustment

- 1 Press the MENU button to display the On-Screen Menu. Use the Point ◀▶ buttons to move the red frame pointer to the Image Adjust Menu icon.
- 2 Use the Point ▲▼ buttons to move the red frame pointer to the desired item and then press the SELECT button to display the adjustment dialog box. Use the Point ◀▶ buttons to adjust the setting value.

### Contrast

Press the Point ◀ button to decrease the contrast; press the Point ▶ button to increase the contrast (from 0 to 63).

### Brightness

Press the Point ◀ button to decrease the brightness; press the Point ▶ button to increase the brightness (from 0 to 63).

### Color temp.

Use the Point ◀▶ buttons to select the desired Color temp. level (High, Mid, Low, or XLow).

### White balance (Red)

Press the Point ◀ button to lighten red tone; press the Point ▶ button to deepen red tone (from 0 to 63).

### White balance (Green)

Press the Point ◀ button to lighten green tone; press the Point ▶ button to deepen green tone (from 0 to 63).

### White balance (Blue)

Press the Point ◀ button to lighten blue tone; press the Point ▶ button to deepen blue tone (from 0 to 63).

### Sharpness

Press the Point ◀ button to decrease the sharpness of the image; press the Point ▶ button to increase the sharpness of the image (from 0 to 15).

### Gamma

Use the Point ◀▶ buttons to adjust the gamma value to obtain a better balance of contrast (from 0 to 15).

### Reset

To reset the adjusted data, select Reset and press the SELECT button. A confirmation box appears and then select [Yes]. All adjustments will return to their previous figures.

## Image Adjust Menu

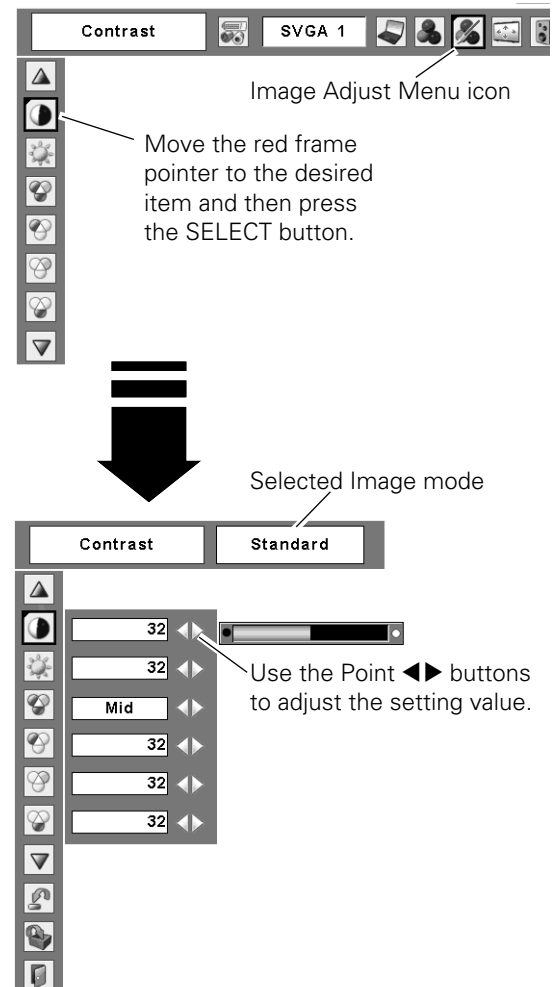

### ✓ Note:

- When the White balance Red, Green, or Blue is adjusted, the Color temp. level will change to "Adj."

## Store

To store the adjusted data, select Store and press the SELECT button. Use the Point ▲▼ buttons to select one from Image 1 to 4 and press the SELECT button. A confirmation box appears and then select [Yes]. Stored data can be called up by selecting an "Image (1–4)" in the Image Mode Selection on page 36.

## Quit

Exit the Image Adjust Menu.

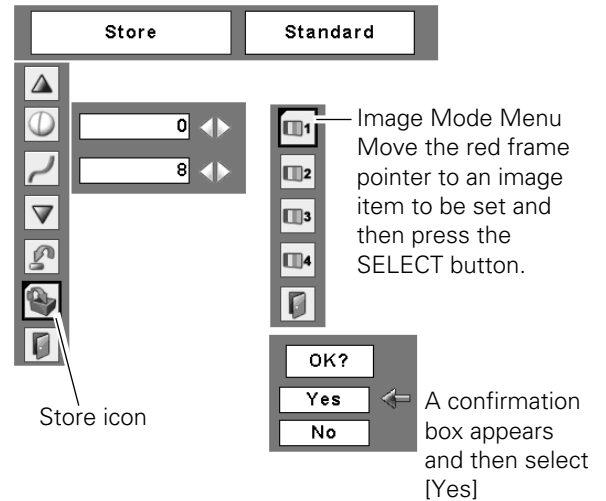

## Screen Size Adjustment

This projector has the picture screen resize function, which enables you to customize the image size.

- 1 Press the MENU button to display the On-Screen Menu. Use the Point ◀▶ buttons to move the red frame pointer to the Screen Menu icon.
- 2 Use the Point ▲▼ buttons to move the red frame pointer to the desired function and then press the SELECT button.

## Normal

Provide the image to fit the screen size.

## True

Provide the image in its original size. When the original image size is larger than the screen size (1024 x 768), the projector enters to the panning mode automatically. Use the Point ▲▼◀▶ buttons to pan the image. When adjusted, the arrows will turn red. When reached to the correction limits, the arrows will disappear.

## Wide

Provide the image to fit the wide video aspect ratio (16:9) by expanding the image width uniformly. This function can be used for providing a squeezed video signal at 16:9.

## Full screen

Provide the full screen image.

## Screen Menu

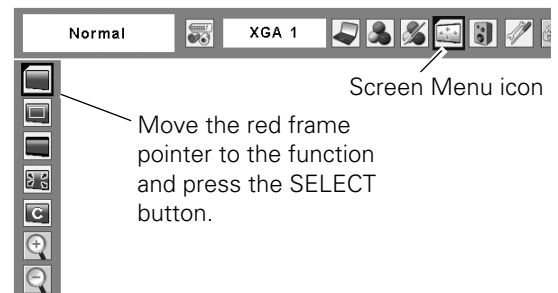

### ✓ Notes:

- The Screen Menu, except for "Normal" and "Custom", cannot be operated when 720p, 1035i, or 1080i is selected in the PC System Menu (p.32).
- This projector cannot display any resolution higher than 1600 x 1200. If your computer's screen resolution is higher than it, reset the resolution to the lower before connecting to the projector.
- The image data in other than 1024 x 768 is modified to fit the screen size in initial mode.
- True, Full screen, and Digital zoom +/- cannot be selected when 480i, 575i, 480p, or 575p is selected in the PC System Menu (p.32).

**C Custom**

Adjust the screen scale and position manually with this function.

Press the SELECT button at Custom and the "Custom" is displayed on the screen for a few seconds and then the Aspect dialog box appears.

- Scale H/V..... Adjust the Horizontal/Vertical screen scale.
- H&V..... When set to "On," the aspect ratio is fixed. The "Scale V" appears dimmed and becomes unavailable. Adjust "Scale H," then the screen scale is automatically modified based on the aspect ratio.
- Position H/V ..... Adjust the Horizontal/Vertical screen position.
- Common ..... Save the adjusted scale to all the inputs. Press the SELECT button at Common to display a confirmation box. To save the scale, press the SELECT button at "Yes." When Custom is selected, the saved scale is used.
- Reset..... Reset the all adjusted values. Press the SELECT button at Reset to display a confirmation box. To reset, press the SELECT button at "Yes."

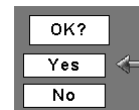
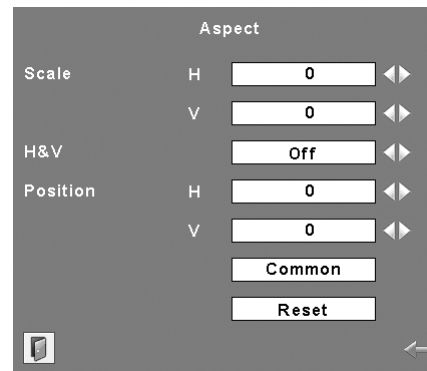

Press the SELECT button at Common or Reset, to display a confirmation box.

**Notes:**

- When no signal is detected, "Normal" is set automatically and the Aspect dialog box disappears.
- The adjustable range for Scale H/V and Position H/V is limited depending on the input signal.

**For zooming in and out the images**

**+ Digital zoom +**

Select Digital zoom +. The On-Screen Menu disappears and "D. zoom +" appears. Press the SELECT button to expand the image size. Use the Point ▲▼◀▶ buttons to pan the image. The Panning function can work only when the image is larger than the screen size.

A projected image can be also expanded by pressing the D.ZOOM ▲ button on the remote control.

**- Digital zoom -**

Select Digital zoom -. The On-Screen Menu disappears and "D. zoom -" appears. Press the SELECT button to compress image size.

The projected image can be also compressed by pressing the D.ZOOM ▼ button on the remote control.

To exit the Digital zoom +/- mode, press any button except the D.ZOOM ▲▼ buttons, SELECT, and Point buttons.

To return to the previous screen size, select a screen size from the Screen Size Adjustment Menu or select an input source from the Input Source Selection Menu (see pages 30–31) again, or adjust the screen size with the D.ZOOM ▲▼ buttons.

**Remote Control**

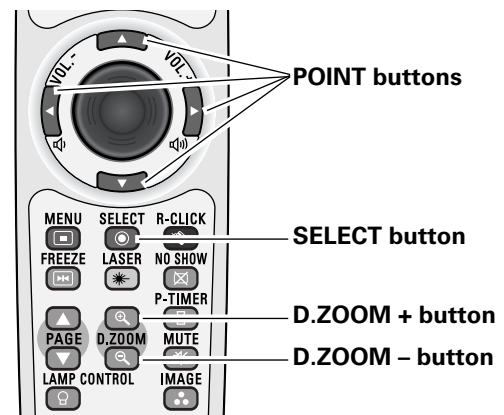

**Notes:**

- The panning function may not operate properly if the stored Mode in the PC Adjust Menu is used (p.35).
- Minimum compression ratio can be limited depending on the input signal or when the Keystone function is working.
- True, Full screen, and Digital zoom +/- cannot be selected when 480i, 575i, 480p, or 575p is selected in the PC System Menu (p.32).
- Digital zoom +/- cannot be selected when Full screen or True is selected.

# Video Input

## Input Source Selection (Video, S-video)

### Direct Operation

Choose Video by pressing the INPUT button on the top control or the VIDEO button on the remote control. Before using these buttons, correct input source should be selected through menu operation as described below.

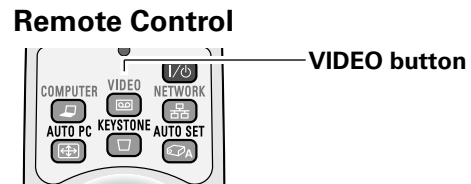
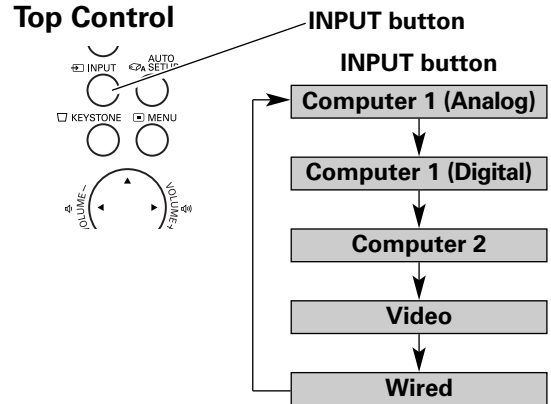

### Menu Operation

- 1 Press the MENU button to display the On-Screen Menu. Use the Point ◀▶ buttons to move the red frame pointer to the Input Menu icon.
- 2 Use the Point ▲▼ buttons to move the red arrow pointer to Video and then press the SELECT button to display the Source Select Menu.
- 3 Move the pointer to the desired source and then press the SELECT button.

**Auto** When selecting Auto, the projector automatically detects incoming video signal, and adjusts itself to optimize its performance. The projector selects connection in the following order:

1. S-video
2. Video

**Video** When video input signal is connected to the VIDEO jack, select Video.

**S-video** When video input signal is connected to the S-VIDEO jack, select S-video.

#### ✓Notes:

- Wired, Wireless, and Memory viewer are for the Network function. See the owner's manual "Network Set-up and Operation" and owner's manual of Memory viewer (optionally available).
- When the Input Search function is set to "On1" or "On2", the input signal will be searched automatically (p.51).

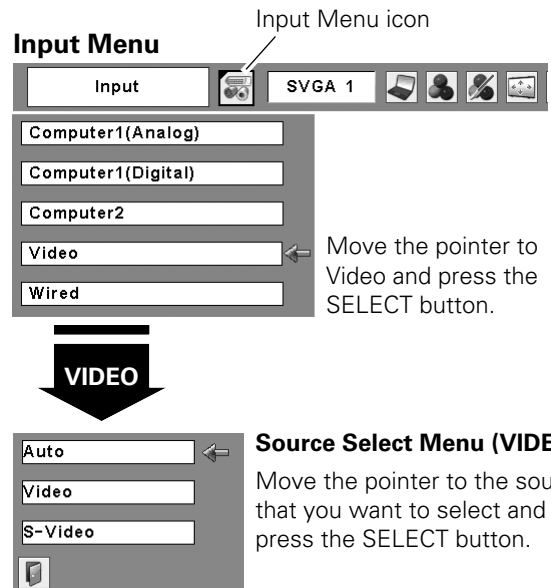



## Input Source Selection (Component, RGB Scart 21-pin)

### Direct Operation

Choose Computer 2 by pressing the INPUT button on the top control or press the COMPUTER button on the remote control.

Before using these buttons, correct input source should be selected through Menu operation as described below.

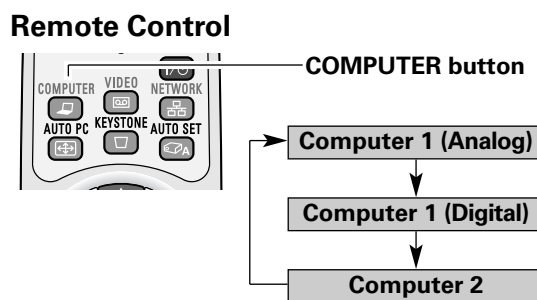
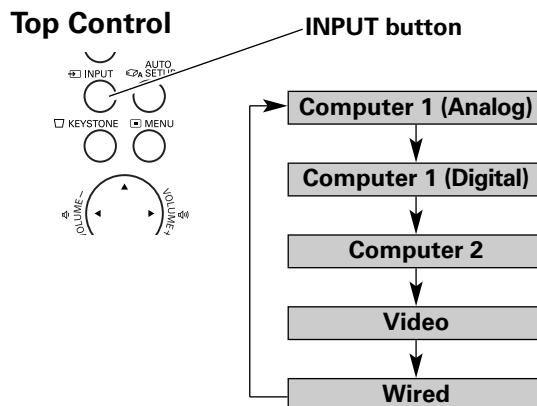

### Menu Operation

- 1 Press the MENU button to display the On-Screen Menu. Use the Point ◀▶ buttons to move the red frame pointer to the Input Menu icon.
- 2 Use the Point ▲▼ buttons to move the red arrow pointer to Computer 2 and then press the SELECT button.
- 3 After the Source Select Menu appeared for Computer 2, move the pointer to Component or RGB(Scart) and then press the SELECT button.

**Component** When the input source is coming from video equipment connected to the COMPUTER IN 2/COMPONENT IN terminal with a Component-VGA Cable, select Component.

**RGB (Scart)** When the input source is coming from video equipment connected to the COMPUTER IN 2/COMPONENT IN terminal with a Scart-VGA Cable, select RGB (Scart).

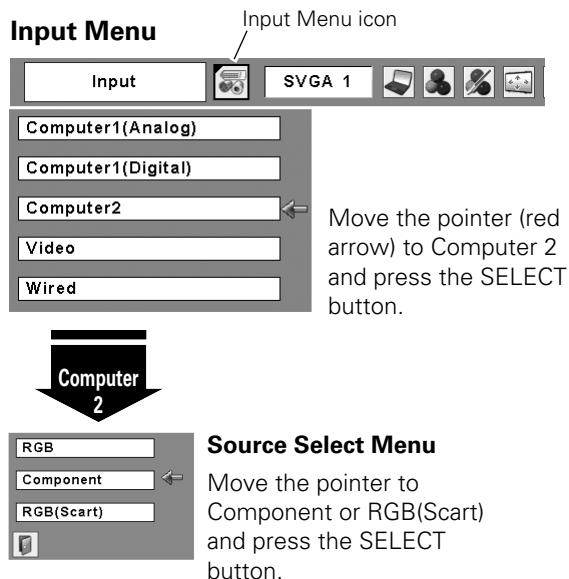

**✓Note:**

- Wired, Wireless, Memory viewer are for the Network function. See owner's manual "Network Set-up and Operation" and owner's manual of Memory viewer (optionally available).
- When the Input Search function is set to "On1" or "On2", the input signal will be searched automatically (p.51).

## Video System Selection

- 1 Press the MENU button to display the On-Screen Menu. Use the Point ◀▶ buttons to move the red frame pointer to the AV System Menu icon.
- 2 Use the Point ▲▼ buttons to move the red arrow pointer to the desired system and then press the SELECT button.

### Video or S-Video

#### Auto

The projector automatically detects an incoming video system, and adjusts itself to optimize its performance. When Video System is PAL-M or PAL-N, select the system manually.

#### PAL/SECAM/NTSC/NTSC4.43/PAL-M/PAL-N

If the projector cannot reproduce proper video image, select a specific broadcast signal format from among PAL, SECAM, NTSC, NTSC 4.43, PAL-M, and PAL-N.

### Component

#### Auto

The projector automatically detects an incoming video signal, and adjusts itself to optimize its performance.

#### COMPONENT VIDEO SIGNAL FORMAT

If the projector cannot reproduce proper video image, select a specific component video signal format from among 480i, 575i, 480p, 575p, 720p, 1035i, and 1080i.

### AV System Menu (Video or S-Video)

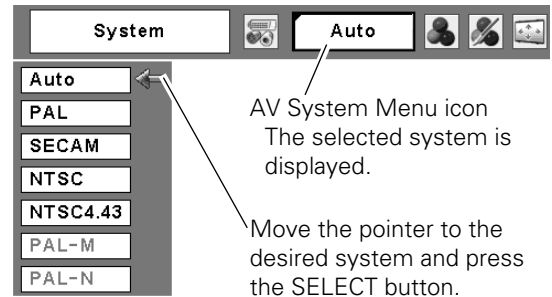

### AV System Menu (Component)

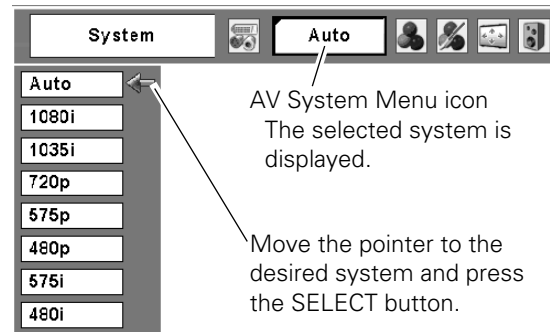

#### ✓Note:

- The AV System Menu cannot be selected when selecting RGB (Scart).

## Image Mode Selection

### Direct Operation

Select the desired image mode from among Dynamic, Standard, Cinema, Blackboard (Green), Image 1, Image 2, Image 3, and Image 4 by pressing the IMAGE button on the remote control.

#### Dynamic

For viewing pictures in a bright room.

#### Standard

Normal picture mode preset on the projector.

#### Cinema

Picture mode adjusted with fine tone.

#### Blackboard (Green)

For the image projected on a blackboard.  
This mode help enhance the image projected on a blackboard.  
This is mainly effective on a green colored board, not truly effective on a black colored board.

#### Image 1-4

For viewing with the user preset image mode in the Image Adjust Menu (see page 44-45). This Image memory is provided in each computer, component, and video input source.

### Menu Operation

- 1 Press the MENU button to display the On-Screen Menu. Use the Point ◀▶ buttons to move the red frame pointer to the Image Select Menu icon.
- 2 Use the Point ▲▼ buttons to move the red frame pointer to the desired image mode and then press the SELECT button.

#### Dynamic

For viewing pictures in a bright room.

#### Standard

Normal picture mode preset on the projector.

#### Cinema

Picture mode adjusted with fine tone.

#### Blackboard(Green)

For the image projected on a blackboard. See above for further description.

#### Image1-4

For viewing with the user preset image mode in the Image Adjust Menu (see page 44-45).

### Remote Control

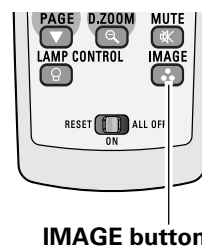

### IMAGE button

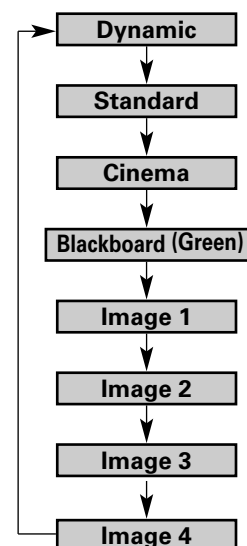

### Image Select Menu

Image Select Menu icon

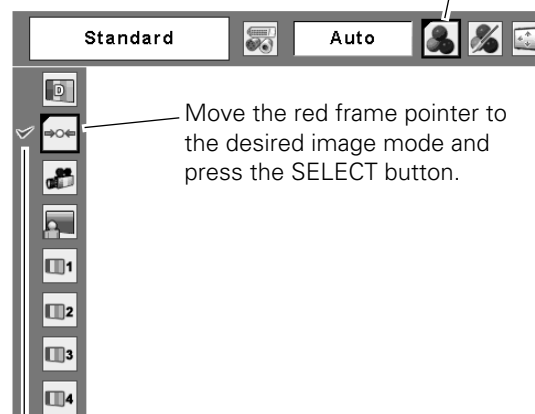

Move the red frame pointer to the desired image mode and press the SELECT button.

The selected image mode is check marked.

## Image Adjustment

- 1 Press the MENU button to display the On-Screen Menu. Use the Point ◀▶ buttons to move the red frame pointer to the Image Adjust Menu icon.
- 2 Use the Point ▲▼ buttons to move the red frame pointer to the desired item and then press the SELECT button to display the adjustment dialog box. Use the Point ◀▶ buttons to adjust the setting value.

### Contrast

Press the Point ◀ button to decrease the contrast; press the Point ▶ button to increase the contrast (from 0 to 63).

### Brightness

Press the Point ◀ button to decrease the brightness; press the Point ▶ button to increase the brightness (from 0 to 63).

### Color

Press the Point ◀ button decrease the intensity of the color; press the Point ▶ button increase the intensity of the color (from 0 to 63).

### Tint

Press the Point ◀▶ buttons to adjust the tint value to get a proper color balance (from 0 to 63).

### Color temp.

Use the Point ◀▶ buttons to select the desired Color temp. level (High, Mid, Low, or XLow).

### White balance (Red)

Press the Point ◀ button to lighten red tone; press the Point ▶ button to deepen red tone (from 0 to 63).

### White balance (Green)

Press the Point ◀ button to lighten green tone; press the Point ▶ button to deepen green tone (from 0 to 63).

### White balance (Blue)

Press the Point ◀ button to lighten blue tone; press the Point ▶ button to deepen blue tone (from 0 to 63).

#### ✓Notes:

- When the White balance Red, Green, or Blue is adjusted, the Color temp. level will change to "Adj."
- Tint cannot be selected when the video system is PAL, SECAM, PAL-M, or PAL-N (p.42).

### Image Adjust Menu

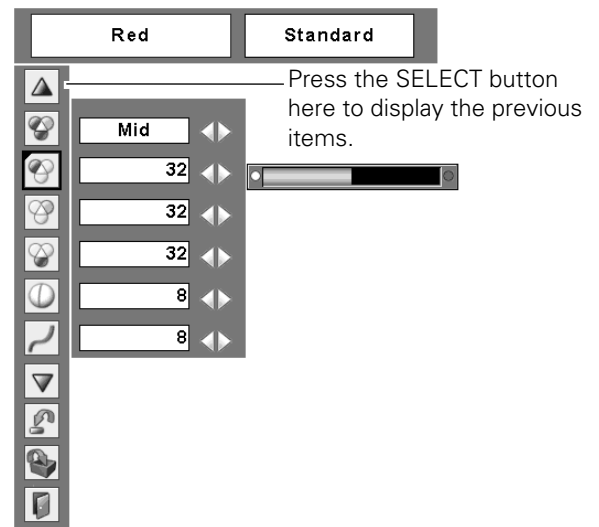
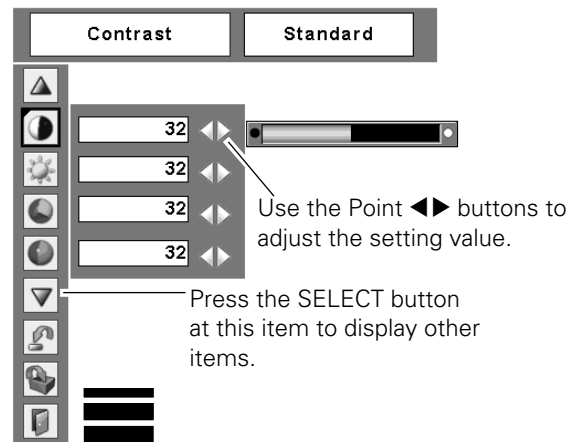
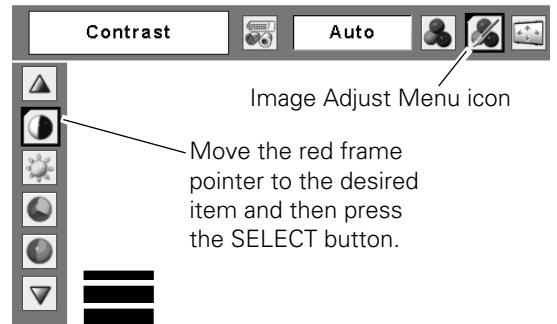

 **Sharpness**

Press the Point ◀ button to decrease the sharpness of the image; press the Point ▶ button to increase the sharpness of the image (from 0 to 15).

 **Gamma**

Use the Point ◀▶ buttons to adjust the gamma value to obtain a better balance of contrast (from 0 to 15).

 **Noise reduction**

Noise interference on the screen can be reduced. Select one of the following options to get smoother images.

- Off..... Disabled.
- L1 ..... Lower reduction
- L2 ..... Higher reduction

 **Progressive**

An interlaced video signal can be displayed in progressive mode. Select one of the following options.

- Off..... Disabled.
- L1 ..... For an active picture.
- L2 ..... For a still picture.
- Film ..... For watching a film. With this function, the projector reproduces pictures faithful to the original film quality.

 **Reset**

To reset the adjusted data, select Reset and press the SELECT button. A confirmation box appears and then select [Yes]. All adjustments will return to their previous figures.

 **Store**

To store the adjusted data, select Store and press the SELECT button. Use the Point ▲▼ buttons to select one from Image 1 to 4 and press the SELECT button. A confirmation box appears and then select [Yes]. Stored data can be called up by selecting an “Image (1–4)” in the Image Select Menu on page 43.

 **Quit**

Exit the Image Adjust Menu.

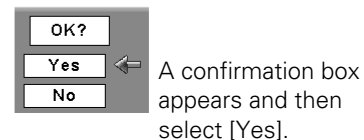
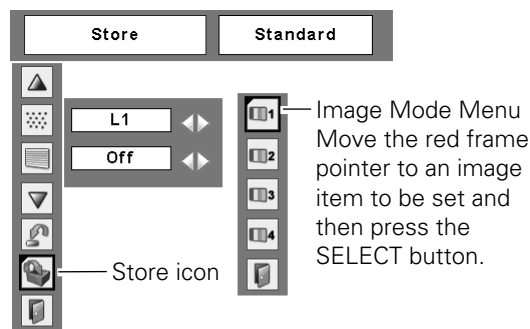

✓ **Notes:**

- Noise reduction and Progressive cannot be selected when 480p, 575p, 720p, 1035i, or 1080i is selected (p.42).
- Reset and Store icons will be displayed when any adjustment is made.

## Screen Size Adjustment

This projector has the picture screen resize function, which enables you to customize the image size.

- 1 Press the MENU button to display the On-Screen Menu. Use the Point ◀▶ buttons to move the red frame pointer to the Screen Menu icon.
- 2 Use the Point ▲▼ buttons to move the red frame pointer to the desired function and then press the SELECT button.

### Normal

Provide the image at the 4:3 normal video aspect ratio.

### Wide

Provide the image at the 16:9 wide screen ratio.

### Custom

Adjust the screen scale and position manually with this function.

Press the SELECT button at Custom and the "Custom" is displayed on the screen for a few seconds and then the Aspect dialog box appears.

- Scale H/V..... Adjust the Horizontal/Vertical screen scale.
- H&V..... When set to "On," the aspect ratio is fixed. The "Scale V" appears dimmed and becomes unavailable. Adjust the "Scale H," then the screen scale is automatically modified based on the aspect ratio.
- Position H/V ..... Adjust the Horizontal/Vertical screen position.
- Common ..... Save the adjusted scale to all the inputs. Press the SELECT button at Common to display a confirmation box. To save the scale, press the SELECT button at "Yes." When Custom is selected, the saved scale is used.
- Reset..... Reset the all adjusted values. Press the SELECT button at Reset to display a confirmation box. To reset, press the SELECT button at "Yes."

#### ✓Notes:

- When no signal is detected, "Normal" is set automatically and the Aspect dialog box disappears.
- The adjustable range for Scale H/V and Position H/V is limited depending on the input signal.
- "Wide" cannot be operated when 720p, 1035i, or 1080i is selected in the AV System Menu (p.42).

### Screen Menu

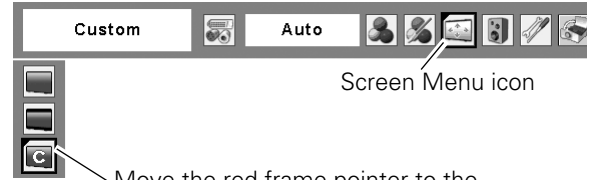

Screen Menu icon

Move the red frame pointer to the desired function and press the SELECT button.

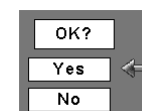
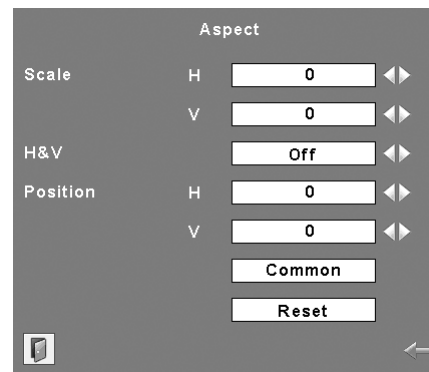

Press the SELECT button at Common or Reset, to display a confirmation box.

# Setting

## Setting

This projector has a Setting menu that allows you to set up the other various functions described below.

- 1 Press the MENU button to display the On-Screen Menu. Use the Point ◀▶ buttons to move the red frame pointer to the Setting Menu icon.
- 2 Use the Point ▲▼ buttons to move the red frame pointer to the desired item and then press the SELECT button. The Setting dialog box appears.

### Language

The language used in the On-Screen Menu is available in English, German, French, Italian, Spanish, Portuguese, Dutch, Swedish, Finnish, Polish, Hungarian, Romanian, Russian, Chinese, Korean, and Japanese.

### Auto setup

This function enables Auto Keystone correction and Auto PC adjustment by pressing the AUTO SETUP button on the top control or the AUTO SET button on the remote control. Settings for those functions can be altered as follows:

#### Auto PC Adj.

- On . . . . . Enables Auto PC Adjustment when pressing the AUTO SET button on the remote control or the AUTO SETUP button on the top control.
- Off . . . . . Disables Auto PC Adjustment.

#### Auto Keystone

- Auto . . . . . Always works and corrects keystone distortion according to the projector's tilt.
- Manual . . . Works only when pressing the AUTO SET button on the remote control or the AUTO SETUP button on the top control.
- Off . . . . . Disables Auto Keystone.

#### ✓ Notes:

- Auto PC Adj. and Auto Keystone cannot be set "Off" at the same time.
- Auto Keystone corrects vertical distortion only, not correct horizontal distortion.
- The Auto Keystone cannot work when Ceiling feature is On in the Setting menu (p.51).
- Perfect correction of the image distortion cannot be ensured with the Auto setup function. If the distortion is not corrected properly by pressing the AUTO SETUP/AUTO SET button, adjust manually by pressing the KEYSTONE button on the remote control or selecting Keystone in the Setting menu (p.26).

### Setting Menu (Language)

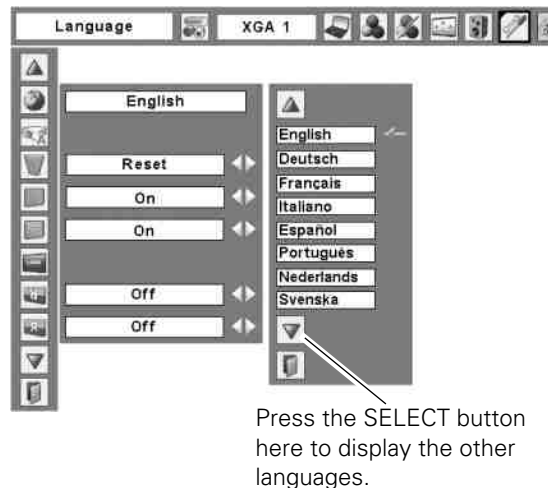
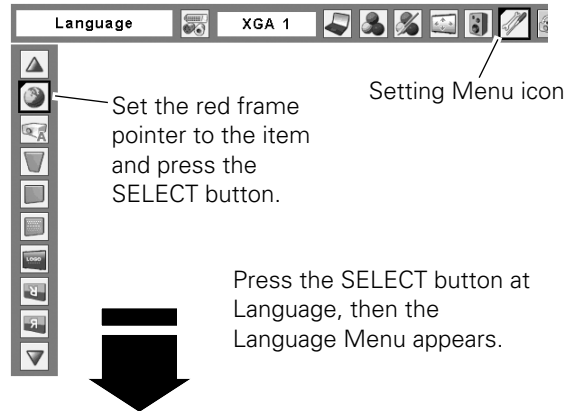

### Auto setup

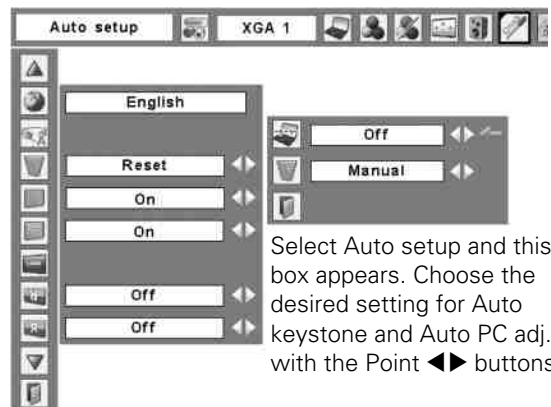



## Keystone

This function is used to store or reset the keystone correction when the AC power cord is unplugged. Use the Point ◀▶ buttons to switch between each option.

Store ..... Keep the keystone correction even when the AC power cord is unplugged.

Reset ..... Release the keystone correction when the AC power cord is unplugged.

To correct keystone distortion, press the SELECT button. The "Keystone" appears on the screen. Use the Point ▲▼ buttons to correct keystone distortion (p.26).



## Blue back

When this function is "On," a blue image is displayed while the input signal is not detected.



## Display

This function decides whether to display On-Screen Displays.

On ..... Show all the On-Screen displays. Use this function when you want to project images after the lamp becomes bright enough. The factory default setting is in this option.

Countdown Off ..... Show the input image instead of the countdown when turning on the projector. Use this function when you want to project the image as early as possible even when the lamp is not bright enough.

Off ..... Hide the On-Screen Displays except;

- On-Screen Menu
- "Power off?" (p.23)
- P-Timer
- "No signal" for Power management (p.52)
- "Please wait ..."
- White arrows for the True function in the Screen Menu (p.38)

## Keystone

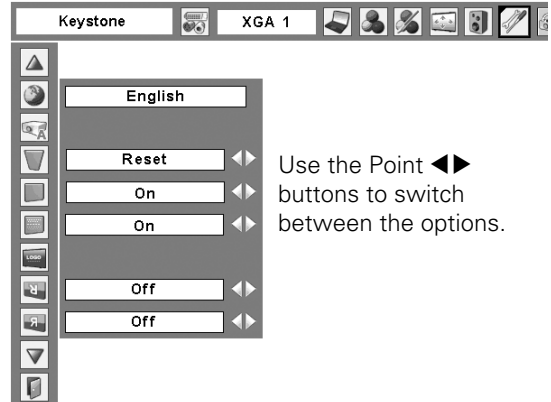



 **Logo (Logo and Logo PIN code lock settings)**

This function allows you to customize the screen logo with Logo select, Capture, and Logo PIN code lock functions.

✓ **Note:**

- When “On” is selected in the Logo PIN code lock function, Logo select and Capture functions cannot be selected.

 **Logo select**

This function decides on the starting-up display from among following options.

- User ..... Show the image you captured
- Default ..... Show the factory-set logo
- Off..... Show the countdown display only

 **Capture**

This function enables you to capture an image being projected to use it for a starting-up display or interval of presentations.

Select Capture and press the SELECT button. A confirmation box appears and select [Yes] to capture the projected image.

After capturing the projected image, go to the Logo select function and set it to “User”. Then the captured image will be displayed the next time you turn on the projector or when you press the NO SHOW button (see page 29).

To cancel the Capture function, select [No].

✓ **Notes:**

- Before capturing an image, select “Standard” in the Image Select Menu to capture a proper image (pp.36, 43).
- A signal from a computer can be captured up to XGA (1024 x 768). A signal from video equipment can be captured except for 720p, 1035i, and 1080i.
- When capturing the image that has been adjusted by the Keystone function, the adjusted data is automatically reset and the projector captures an image without keystone correction.
- When the Logo PIN code lock function is set to “On,” the Capture function cannot be selected.
- When starting to capture a new image, the previously stored image is cleared even if you cancel the capturing.

**Logo select**

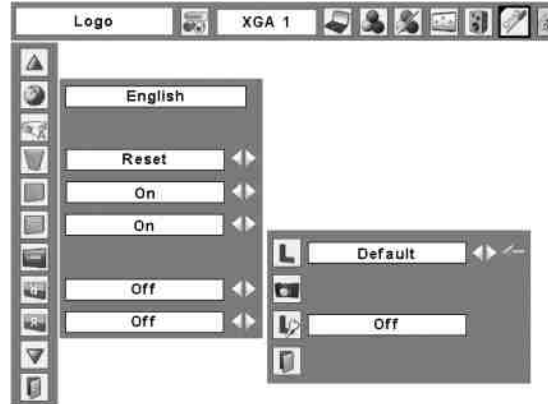

**Capture**

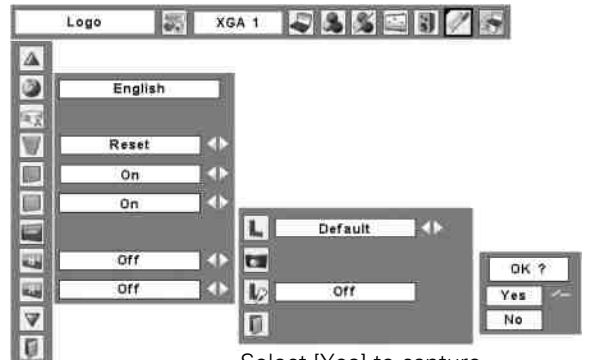

Select [Yes] to capture the projected image.



 **Logo PIN code lock**

This function prevents an unauthorized person from changing the screen logo.

- Off..... The screen logo can be changed freely from the Logo Menu (p.49).
- On ..... The screen logo cannot be changed without a Logo PIN code.

If you want to change the Logo PIN code lock setting, press the SELECT button and the Logo PIN code dialog box appears. Enter a Logo PIN code by following the steps below. The initial Logo PIN code is set to "4321" at the factory.

**Enter a Logo PIN code**

Use the Point ▲▼ buttons to enter a number. Press the Point ► button to fix the number and move the red frame pointer to the next box. The number changes to "\*." If you fixed an incorrect number, use the Point ◀ button to move the pointer to the number you want to correct, and then enter the correct number.

Repeat this step to complete entering a four-digit number.

After entering the four-digit number, move the pointer to "Set." Press the SELECT button so that you can start to operate the projector.

If you entered an incorrect Logo PIN code, "Logo PIN code" and the number (\*\*\*\*) will turn red for a moment. Enter the correct Logo PIN code all over again.

**Change the Logo PIN code lock setting**

Use the Point ◀▶ button to switch On/Off, and then press the Point ▼ button to move the pointer to "Quit." Press the SELECT button to close the dialog box.

**Change the Logo PIN code**

Logo PIN code can be changed to your desired four-digit number. Press the Point ▼ button to select "Logo PIN code change" and then press the SELECT button. The New Logo PIN code input dialog box appears. Set a new Logo PIN code.

Be sure to note the new Logo PIN code and keep it at hand. If you lost the number, you could no longer change the Logo PIN code setting. For details on PIN code setting, refer to "PIN code lock" on pages 54–55.

**Logo PIN code lock**

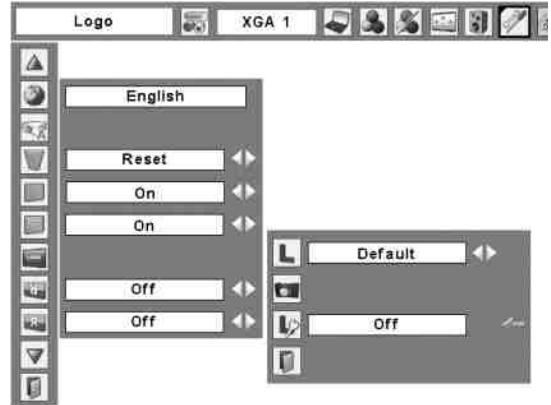

**Enter a Logo PIN code**

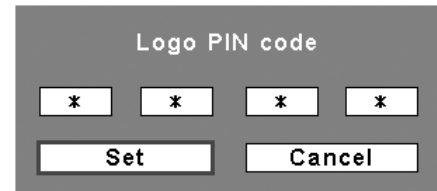

After a correct Logo PIN code is entered, the following dialog box appears.

**Change the Logo PIN code lock setting**



Use the Point ◀▶ buttons to switch On/Off.

**Change the Logo PIN code**

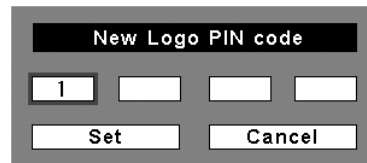

**CAUTION:**  
**WHEN YOU HAVE CHANGED THE LOGO PIN CODE, WRITE DOWN THE NEW PIN CODE IN COLUMN OF THE LOGO PIN CODE NO. MEMO ON PAGE 78, AND KEEP IT SECURELY. SHOULD THE LOGO PIN CODE BE LOST OR FORGOTTEN, THE LOGO PIN CODE SETTING CAN NO LONGER BE CHANGED.**

 **Ceiling**

When this function is set to "On," the picture will be top/bottom and left/right reversed. This function is used to project the image from a ceiling-mounted projector.

**Ceiling**

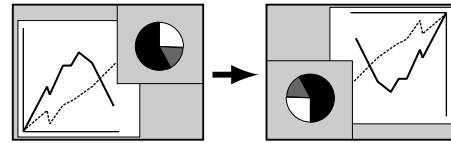

 **Rear**

When this function is set to "On," the picture will be left/right reversed. This function is used to project the image from rear of the screen.

**Rear**

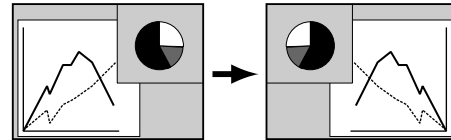

 **Input search**

This function detects the input signal automatically. When a signal is found, the search will stop. Use the Point ◀▶ buttons to select one of the following options.

- Off..... Input search will not work.
- On1 ..... Input search works under the following situation.
  - When pressing the INPUT button on the top control.
  - When pressing the COMPUTER button or VIDEO button on the remote control.
- On2 ..... Input search works under the following situation.
  - When turning on the projector by pressing the ON/STAND-BY button on the top control or the remote control.
  - When pressing the COMPUTER button or VIDEO button on the remote control.
  - When pressing the INPUT button on the top control.
  - When the current input signal is cut off.\*

\*If the No show or Freeze function is active, cancel it to activate the Input search. It is also unavailable when On-Screen menu is displayed.

**✓Notes:**

- While Input search is set to "On1" or "On2," the status of Input and Lamp are displayed every time the signal is switched.
- Only the last selected input source can be detected.
- If the INPUT button on the top control or COMPUTER or VIDEO buttons on the remote control is pressed during Input search is in progress, Input search will stop and go back to the previous input signal.



## Standby mode

This function is available when operating the projector via network.

Normal ..... Supply the power to the network function even after turning off the projector. You can turn on/off the projector via network, modify network environment, and receive an e-mail about projector status while the projector is powered off.

Eco ..... Select "Eco" when you do not use the projector via network. The projector's network function will stop when turning off the projector.

Refer to the owner's manual "Network Setup and Operation."

### ✓Note:

- When selecting Normal, the cooling fans may be running depending on the temperature inside the projector even if the projector is turned off.



## Power management

For reducing power consumption as well as maintaining the lamp life, the Power management function turns off the projection lamp when the projector is not operated for a certain period.

If the input signal is interrupted and no button is pressed for more than 30 seconds, the timer display with "No signal" appears. It starts the countdown until the lamp is turned off. Use the Point ◀▶ buttons to set the countdown timer.

Select one of the following options:

Ready ..... When the lamp has been fully cooled down, the POWER indicator changes to green blinking. In this condition, the projection lamp will be turned on if the input signal is reconnected or any button on the top control or remote control is pressed.

Shut down ..... When the lamp has been fully cooled down, the power will be turned off.

Off ..... Power management function is off.

### ✓Note:

Factory default is "Ready: 5 min."

## Power management



Time left before Lamp is off.

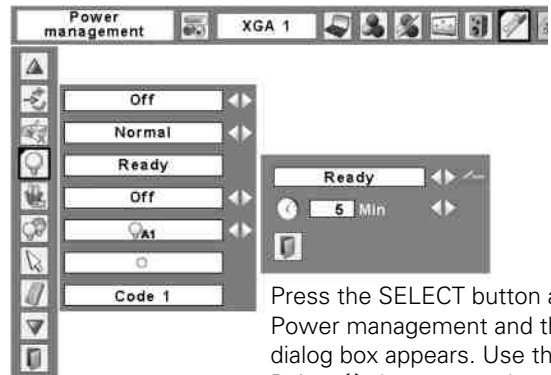

Press the SELECT button at Power management and this dialog box appears. Use the Point ◀▶ buttons to choose one of the three options. Press the Point ▼ button to select the timer, and then use the Point ◀▶ buttons to set timer.



**On start**

When this function is set to "On," the projector will be automatically turned on just by connecting the AC power cord to a wall outlet.

**✓Note:**

- Be sure to turn off the projector properly (see "Turning Off the Projector" on page 23). If the projector is turned off in the incorrect sequence, the On start function does not work properly.



**Lamp control**

This function allows you to change brightness of the screen.

- Auto ..... The brightness according to the input signal (between High and Eco mode).
- High ..... Brighter than the Normal mode.
- Normal ..... Normal brightness
- Eco ..... Lower brightness reduces the lamp power consumption and extends the lamp life.



**Pointer**

You can emphasize a part of the projected image with this function. Use the Point ▲▼ buttons to choose either Spotlight or Pointer and press the SELECT button. Then use the Point ◀▶ buttons to select a size of the Spotlight (Large, Middle, or Small) or a pattern of the Pointer (Arrow, Finger, or Dot). See "Pointer Function" on page 14.

**Pointer**

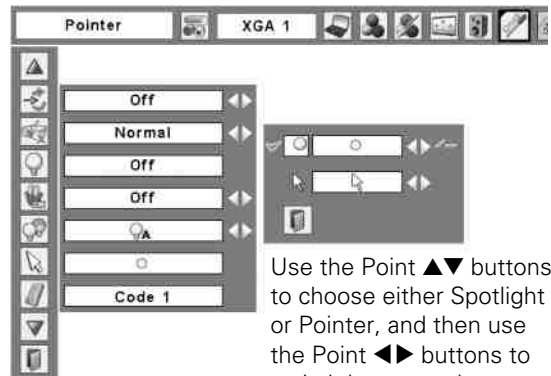

Use the Point ▲▼ buttons to choose either Spotlight or Pointer, and then use the Point ◀▶ buttons to switch between the options.



**Remote control**

The eight different remote control codes (Code 1–Code 8) are assigned to the projector; the factory-set, initial code (Code 1) and the other seven codes (Code 2 to Code 8).

The same code should set on both the projector and the remote control. For example, operating the projector in "Code 7", the remote control code also must be switched to "Code 7".

**To change the code for the projector**

Select a remote control code in this Setting Menu.

**To change the code for the remote control:**

While holding down the MENU button, press the IMAGE button the number of times corresponding to the remote control code for the projector. See "Remote Control Code" on page 15.

**Remote control**

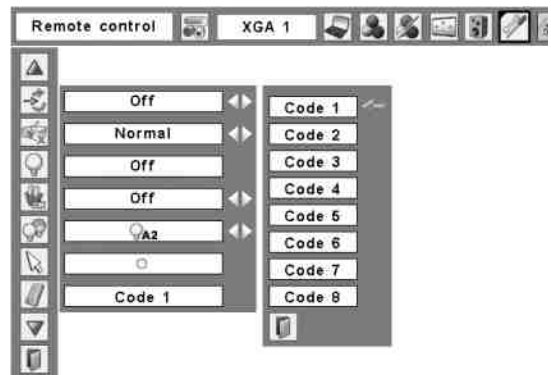



 **Security (Key lock, PIN code lock, Alarm settings)**

This function allows you to use the Key lock, PIN code lock, and Alarm function to set the security for the projector operation.

 **Key lock**

This function locks the top control and remote control buttons to prevent operation by unauthorized persons.

-  ..... Unlocked.
-  ..... Lock the operation of the top control. To unlock, use the remote control.
-  ..... lock the operation of the remote control. To unlock, use the top control.

If the top control accidentally becomes locked and you do not have the remote control nearby or there is something wrong with your remote control, contact the dealer where you purchased the projector or the service center.

 **PIN code lock**

This function prevents the projector from being operated by unauthorized persons and provides the following setting options for security.

- Off..... Unlocked.
- On1 ..... Enter the PIN code every time turning on the projector.
- On2 ..... Enter the PIN code to operate the projector once the power cord is disconnected; as long as the AC power cord is connected, the projector can be operated without a PIN code.

Whenever you change the PIN code lock setting or the PIN code (the four-digit number), you are required to enter the PIN code. The "1234" is set as the initial PIN code at the factory.

If you want to change the PIN code lock setting, Press the SELECT button and the PIN code dialog box appears.

**Key lock**

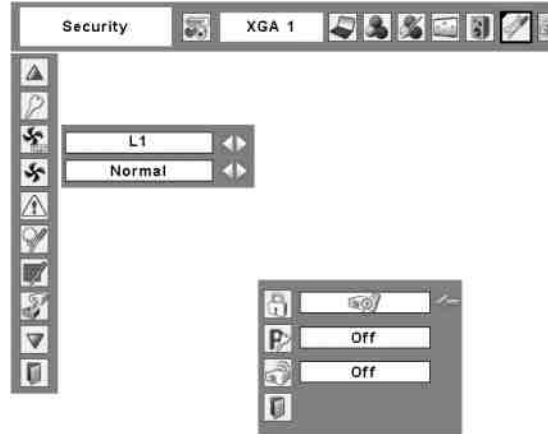

Select Key lock. Use the Point ▲▼ buttons to choose one of the options and select [Yes] to activate it.

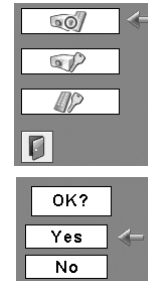

**PIN code lock**

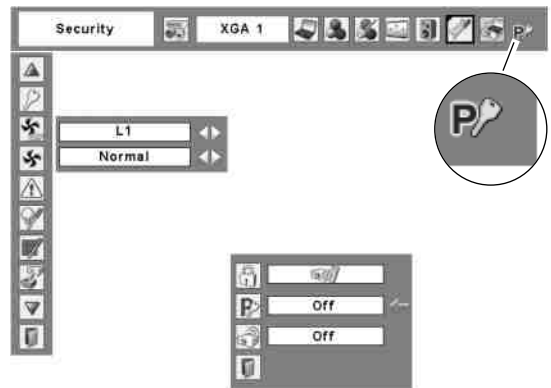

When the projector is locked with a PIN code, the PIN code lock symbol appears on the menu bar.

## Enter a PIN code

Use the Point ▲▼ buttons to enter a number. Press the Point ► button to fix the number and move the red frame pointer to the next box. The number changes to “\*.” If you fixed an incorrect number, use the Point ◀ button to move the pointer to the number you want to correct, and then enter the correct number.

Repeat this step to complete entering a four-digit number.

After entering the four-digit number, move the pointer to “Set.” Press the SELECT button so that you can start to operate the projector.

If you entered an incorrect PIN code, “PIN code” and the number (\*\*\*\*) will turn red for a moment. Enter the correct PIN code all over again.

## Change the PIN code lock setting

Use the Point ◀► buttons to select Off, On1, or On2 and then move the pointer to “Quit” with the Point ▼ button. Press the SELECT button to close the dialog box.

## Change the PIN code

The PIN code can be changed to your desired four-digit number. Press the Point ▼ buttons to select “PIN code change” and press the SELECT button. The New PIN code input dialog box appears. Set a new PIN code.

**CAUTION:**  
**WHEN YOU HAVE CHANGED THE PIN CODE, WRITE DOWN THE NEW PIN CODE IN COLUMN OF THE PIN CODE NO. MEMO ON PAGE 78, AND KEEP IT SECURELY. IF YOU FORGET YOUR PIN CODE, THE PROJECTOR CAN NO LONGER BE STARTED.**

## Alarm

This function allows you to configure the Alarm operation. See “How to Use the Antitheft Alarm Function” on pages 58–61.

## Enter a PIN code

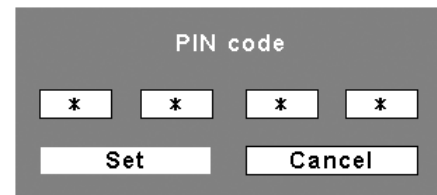

After a correct PIN code is entered, the following dialog box appears.

## Change the PIN code lock setting



Use the Point ◀► buttons to switch between the options.

## Change the PIN code

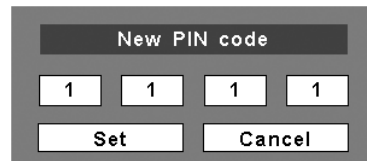



## Fan

This function provides the following options in the cooling fans' operation when the projector is turned off (p.23).

- L1..... Normal operation
- L2..... Slower and lower-sound than the normal operation (L1), but it takes more time to cool the projector down.



## Fan control

Choose the running speed of cooling fans from the following options.

- Normal ..... Normal speed
- Max..... Faster than the normal speed.

This function is used to set the cooling fans' operation to the projector's setting environment. Set this function properly in accordance with the projector's installation method. Otherwise, the cooling fans will not work properly and that causes malfunctions of the projector and decreases the lamp life.

Be sure to set the Fan control in MAX in the setting menu when the projector is inclined between +40 degrees to +140 degrees to the horizontal plane.



## Warning log

This function records anomalous operations while the projector is in operation and use it when diagnosing faults. Up to 10 warning logs are displayed with the latest warning message at the top of the list, followed by previous warning messages in chronological order.

### ✓Note:

- When the Factory default function is executed, all the warning log records will be deleted.



## Lamp counter

This function is used to reset the lamp counter.

When the lamp life is left less than 100 hours, the Lamp replacement icon (Fig.1) will appear on the screen, indicating that the end of lamp life is approaching.

When the lamp life is counted down to 0 hour, the Lamp replacement icon (Fig.2) will appear on the screen, indicating that the end of lamp life is reached.

When replacing the projection lamp, reset the lamp counter. See "Resetting the Lamp Counter" on page 66.

### ✓Note:

- The Lamp replacement icons (Fig.1 and Fig.2) will not appear when the Display function is set to "Off" (p.48), during "Freeze" (p.28), or "No show" (p.29).

## Fan

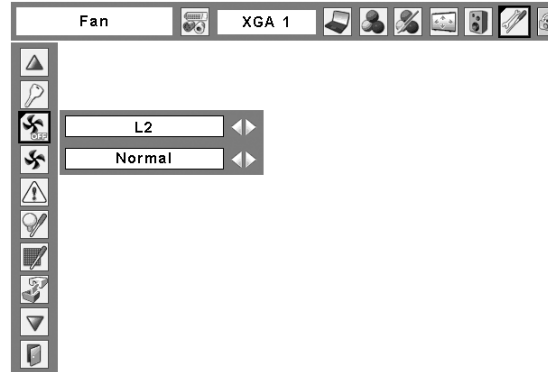

## Fan Control Setting

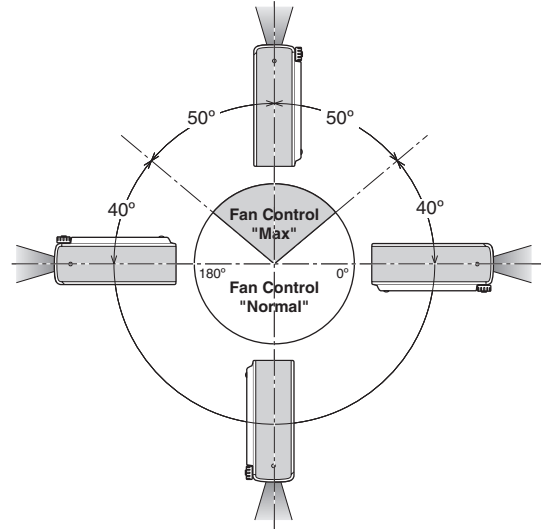

Fig.1 Lamp replacement icon



This icon appears on the screen when the end of lamp life is approaching.

### ✓Note:

- This icon also appears at turning on and selecting input source.

Fig.2 Lamp replacement icon



This icon appears on the screen when the end of lamp life is reached.

### ✓Note:

- At turning on, the icon (Fig.2) will appear. At selecting input source, the icon (Fig.1) will appear.



 **Filter counter**

This function is used to set a frequency for the filter cleaning.

When the projector reached a specified time between cleanings, a Filter warning icon appears on the screen, notifying the cleaning is necessary. After cleaning the filter, be sure to select RESET and set the timer. The Filter warning icon will not turn off until the filter counter is reset.

For details about resetting the timer, refer to "Resetting the Filter Counter" on page 63.

 **Factory default**

This function returns all setting values except for the user logo, PIN code lock, Logo PIN code lock, lamp counter, Antitheft alarm function when it is set on and filter counter to the factory default settings.

 **Quit**

Exit the Setting Menu.

**Filter counter**

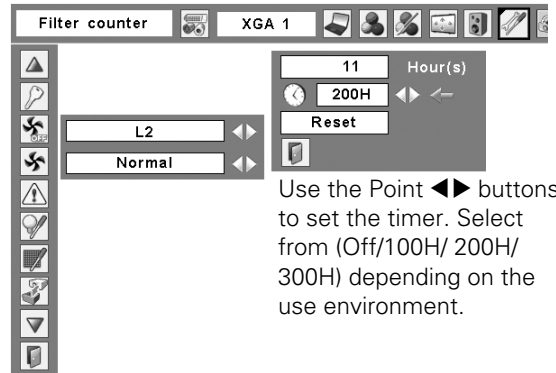

Use the Point ◀▶ buttons to set the timer. Select from (Off/100H/ 200H/ 300H) depending on the use environment.

**Fig.3** Filter warning icon



Filter warning icon appears on the screen at a set time.

**✓Note:**

- This icon also appears at turning on.

**Fig.4** Filter warning icon



**✓Notes:**

- At selecting input source, the icon (Fig.4) will appear.
- The Filter warning icons (Fig.3 and Fig.4) will not appear when the Display function is set to "Off" (p.48), during "Freeze" (p.28), or "No show" (p.29).

**Factory default**

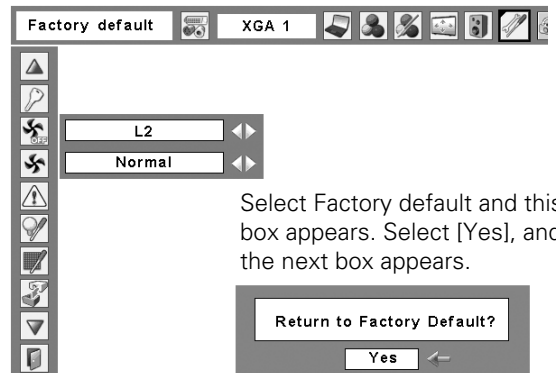

Select Factory default and this box appears. Select [Yes], and the next box appears.

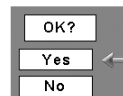
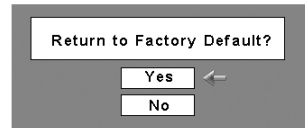

Select [Yes] to activate it.

# Antitheft Alarm Function

## How to Use the Antitheft Alarm Function

Antitheft alarm function is provided to prevent the projector from being stolen. When this function is set to "On," the alarm rings as an unauthorized person tries to move the projector.

To activate the Alarm function for the first time after purchase, you must turn on the power once.

### ✓Notes:

- This function is not a guarantee against stealing.
- The alarm does not ring while the AC power cord is connected to an outlet even if the projector detects vibrations.
- The alarm will stop, as the AC power cord is connected to an outlet, except when the battery cover is open.
- Pressing the buttons is always accompanied by a sound. If no sound is produced after pressing a button, you need to press it again.

The Alarm function is operated by a built-in rechargeable battery. The alarm will not work properly if the battery is not charged enough. See page 60 for details.

## Set and release the Antitheft alarm function

The Alarm setting and release and PIN Code change can be made without an AC power connection.

### Set the alarm

Press the F button three times to turn the alarm function on. The ALARM indicator blinks for a few seconds and the projector enters the warning mode. (If the battery is not charged enough for the alarm function to operate normally, it bleeps and the Alarm indicator will blink red every 20 seconds.)

During the Antitheft alarm function is on, the projector emits a low-pitched sound when it detects vibration.

When the projector does not detect vibration for a few seconds after the sound, it goes back to the warning mode.

When the projector detects more vibrations after the low-pitched sound, the alarm starts ringing.

The Alarm operating configuration (Battery charge, Alarm volume, Sensitivity, and Ringing time) can be selected in the menu. See page 59.

### ✓Notes:

- You can test the alarm sound without setting the alarm function. Press and hold the F button, then the alarm starts ringing. The duration of the alarm sound is the same as the "Ringing Time" setting (p.59).
- If you want to stop the alarm while it is ringing, insert the AC power cord to an outlet or press the F button and enter the four-digit PIN code number.

### Release the alarm setting

Press the F button and enter the four-digit PIN code number within about 10 seconds. (The default PIN code is set to "1111.") When the alarm is released, you will hear a high-pitched confirmation sound.

When you enter an incorrect PIN code, you will hear a low-pitched sound. If you enter an incorrect PIN code three times in a row, the alarm will start ringing.

### Top Control

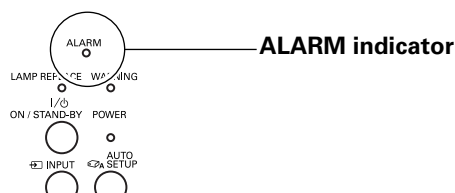

### Rear Terminal

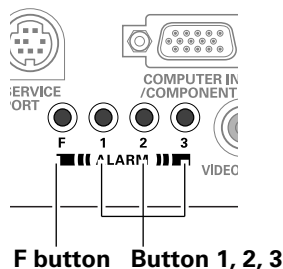

## Other settings

### Change the PIN code

- 1 Press the F button and enter the four-digit PIN code number within about 10 seconds. The ALARM indicator blinks red for a few seconds and a high-pitched confirmation sound is produced.
- 2 While the indicator is blinking, enter a new PIN code, then you will hear a high-pitched confirmation sound and the ALARM indicator is turned off.

When you enter an incorrect PIN code, you will hear a low-pitched sound. If you enter incorrect PIN code three times in a row, the alarm will start ringing.

The PIN code for the Antitheft alarm function is a combination of 1, 2, or 3. Use the buttons 1, 2, and 3 to enter the PIN code. The default PIN code is "1111."

### Reset the settings

Select "Factory default" in the Setting menu to reset the settings for the Antitheft alarm function.

**✓Note:**

- This is effective only when the Antitheft alarm setting is released.

### Alarm operating configuration

The Alarm operating configuration can be changed when the Antitheft alarm function is set to "Off." See page 58 for setting or releasing this function.

Press the SELECT button at Alarm icon in the Setting Menu to display the Alarm setting dialog box. Use the Point ▲▼ buttons to select the desired option; use the Point ◀▶ buttons to set the selected option.

#### Battery charge

See the next page for details.

#### Alarm volume

Small, Medium, Large

#### Sensitivity

- Low .....Less sensitive
- Medium .....Normal sensitivity
- High .....Highly sensitive (default)

#### Ringing time

- 10 seconds .....Rings about 10 seconds (default).
- 60 seconds .....Rings about 60 seconds.
- Long time .....Rings until the end of the battery life.

**CAUTION:**

**WHEN YOU HAVE CHANGED THE PIN CODE, WRITE DOWN THE NEW PIN CODE IN COLUMN OF THE PIN CODE NO. MEMO ON PAGE 78, AND KEEP IT SECURELY. IF YOU FORGET YOUR PIN CODE, SOME SETTINGS OF THE ANTITHEFT ALARM FUNCTION CAN NO LONGER BE CHANGED.**

## Top Control

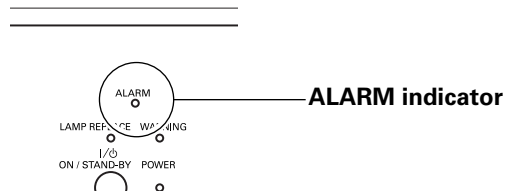

## Rear Terminal

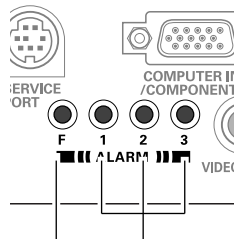

F button Button 1, 2, 3

## Alarm

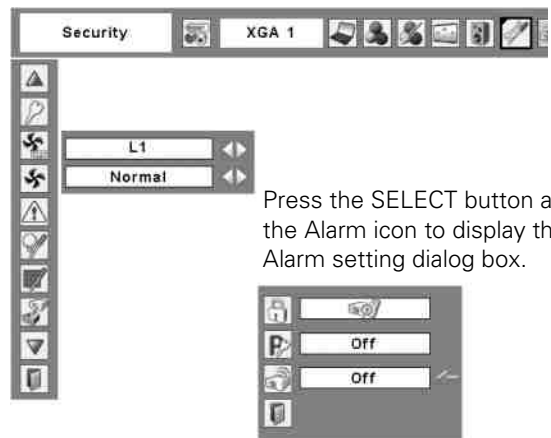

Press the SELECT button at the Alarm icon to display the Alarm setting dialog box.

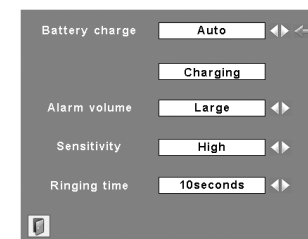

Use the Point ◀▶ buttons to set the selected option.

**✓Notes:**

- The Alarm icon appears dimmed and can be unavailable when the Antitheft alarm function is set to "On" or if the battery is not installed, discharged, or coming to the end of its life.
- When the "Security" is selected in the Setting menu, the Antitheft alarm setting buttons can be unavailable.
- When selecting "Long time" option in the Ringing time, the duration of alarm sounding differs depending on the battery life.

### Charge the built-in batteries

Set the Battery charge option in the Alarm setting menu to "Auto." The default setting is "Auto."

As long as the AC power cord is connected and this option is set to "Auto," the built-in battery for Alarm function is being charged at all times. While charging the battery, "Charging" is displayed in the menu.

The "Charging" appears dimmed when the battery is fully charged or the Battery charge option is set to "Off," or if charging malfunction occurs. Set the option to "Off" when not using the Alarm function. This can save the power and battery life.

### Replace the rechargeable batteries

Use only the specified battery for this projector. Using other types of battery may cause accident or fire hazard.

Replacement Battery: SANYO Ni-MH BATTERY PACK  
Part No. 645 089 8587

### How to replace the rechargeable batteries

- 1 Unplug the AC power cord from a wall outlet.
- 2 Set the Alarm function to "Off" (see page 58). If it is not released, the alarm will start ringing when you try to remove the rechargeable battery cover.
- 3 Remove the screw from the rechargeable battery cover and open the cover.
- 4 Pull out the battery connector and remove the battery.
- 5 Install new battery and plug the connector into the socket.  
**Note:** The battery connector has polarity. Observe battery polarity when installing.
- 6 Put back the battery cover and secure it with the screw.  
**Caution:** Tighten the screw securely. If you fail to do so, the alarm will not operate. Do not use any other screws. This may cause damage to the projector.

#### ✓Note:

- The PIN code and settings you have changed are effective even after the battery is changed.
- Unplug the battery connector if you carry your projector frequently and use the carrying case. If you do not unplug the battery connector, the alarm may be triggered when the Alarm buttons are accidentally pressed inside the carrying case..

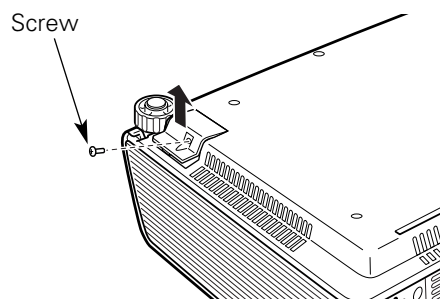

Remove the screw and open the battery cover.

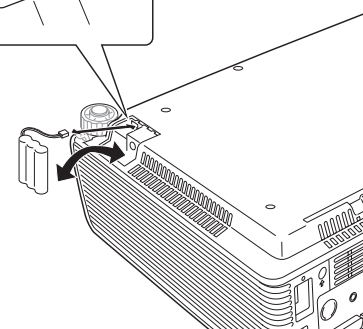
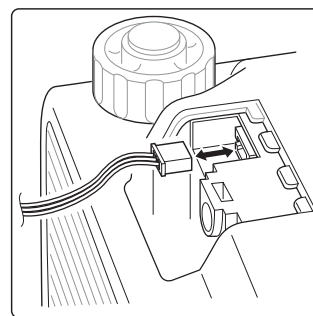

Install the battery, then put back the battery cover and secure it with the screw.



### SAFETY PRECAUTIONS FOR SANYO Ni-MH BATTERY PACK

Observe the following precautions when handling the built-in battery pack of the projector:

- MAKE SURE THAT THE BATTERY PACK IS INSTALLED IN THE PROJECTOR WHEN RECHARGING. USING THE CHARGERS OTHER THAN THE PROJECTOR MAY CAUSE EXPLOSION OR A FIRE.
- The rechargeable battery pack is for use exclusively with this projector. Do not use in other products or this may cause accident.
- Do not throw the battery into fire or heat it. Doing so may cause an explosion or fire.
- Never attempt to disassemble, modify, reconstruct, or solder lead wires directly on to the battery.
- Do not drop or subject to strong forces. Doing so may cause the battery to leak fluid or explode.
- Do not expose to direct sunlight or high temperatures. This may degrade battery performance or cause leakage.
- Avoid contact with water or liquid. Exposure to water or liquid could result in battery corrosion or damage.
- Keep out of reach of children. They may accidentally swallow the battery.
- Do not short-circuit battery terminals with metal objects. Do not store with metal objects or in a metal case.
- The rechargeable battery pack has a limited number of charge cycles and eventually need to be replaced. If it can no longer be recharged, stop charging immediately and replace it with new one.
- Recharge the battery in a place where the temperature is always between **32°F to 104°F (0°C to 40°C)**. Charging in the temperature out of this range may result in fluid leak, heat generation, or shortening battery life.
- If you do not use the projector or the Antitheft alarm function for a long period of time, remove the battery from the projector and store it in a place where the temperature is always between **-4°F to 86°F (-20°C to 30°C)**.
- If a battery leaks and fluid comes in contact with skin, this may cause skin irritation. Flush the affected area thoroughly with water.
- If a battery leaks and fluid gets in contact with eyes, wash your eyes with water immediately and seek medical attention.
- Dispose of used batteries according to your local disposal rule and guidelines.



回收標誌

# Maintenance and Cleaning

## Warning Indicator

The WARNING indicator shows the state of the function which protects the projector. Check the state of the WARNING indicator and the POWER indicator to take proper maintenance.

### **The projector is shut down and the WARNING indicator is blinking red.**

When the temperature inside the projector reaches a certain level, the projector will be automatically shut down to protect the inside of the projector. The POWER indicator is blinking while the projector is being cooled down. When the projector has cooled down enough (to its normal operating temperature), it can be turned on again by pressing the ON/STAND-BY button.

#### ✓ **Note:**

- The WARNING indicator continues to blink even after the temperature inside the projector returns to normal. When the projector is turned on again, the WARNING indicator stops blinking.

#### **Then check the matters below:**

- Did you provide appropriate space for the projector to be ventilated? Check the installing condition to see if the air vents of the projector are not blocked.
- Has the projector been installed near an Air-Conditioning/ Heating Duct or Vent? Move the installation of the projector away from the duct or vent.
- Is the filter clean? Clean the filter periodically.

### **The projector is shut down and the WARNING indicator lights red.**

When the projector detects an abnormal condition, it is automatically shut down to protect the inside of the projector and the WARNING indicator lights red. In this case, unplug the AC power cord and reconnect it, and then turn the projector on once again to verify operation. If the projector cannot be turned on and the WARNING indicator still lights red, unplug the AC power cord and contact the service station.



#### **CAUTION**

DO NOT LEAVE THE PROJECTOR WITH THE AC POWER CORD CONNECTED UNDER AN ABNORMAL CONDITION. IT MAY RESULT IN FIRE OR ELECTRIC SHOCK.

#### Top Control

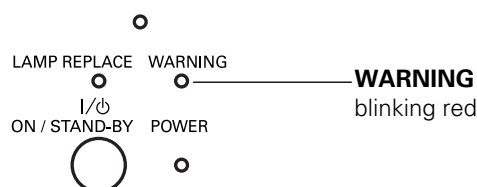

#### Top Control

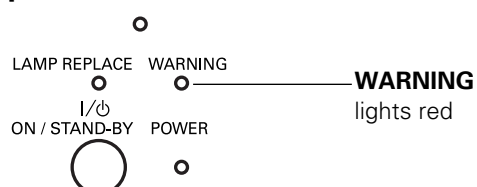

## Cleaning the Filter

Filter prevents dust from accumulating on the optical elements inside the projector. Should the filter becomes clogged with dust particles, it will reduce cooling fans' effectiveness and may result in internal heat buildup and adversely affect the life of the projector. If a "Filter warning" icon appears on the screen, clean the filter immediately. Clean the filter by following the steps below.

- 1** Turn off the projector, and unplug the AC power cord from the AC outlet.
- 2** Turn the projector over and remove the filter by pulling the latches upward.
- 3** Gently clean the filter by using a brush or rinse it softly.
- 4** When rinsing the filter, dry it well. Replace the filter properly. Make sure that the filter is fully inserted to the projector.



### CAUTION

Do not operate the projector with the filter removed. Dust may accumulate on the optical elements degrading picture quality. Do not put anything into the air vents. Doing so may result in malfunction of the projector.

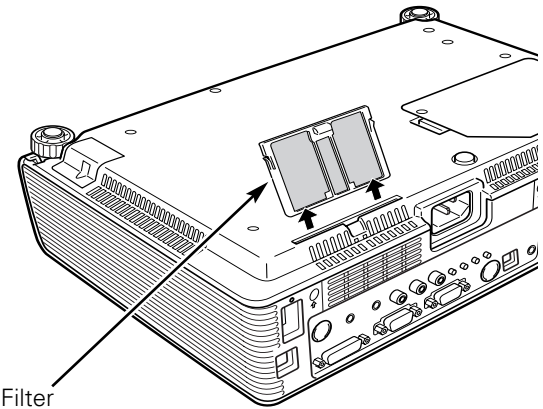

Filter  
Pull up and remove.

### ✓ Note:

- When reinserting this filter, be sure that the slit part is facing the outer side.

## RECOMMENDATION

**We recommend avoiding dusty/smoky environments when you operate the projector. Usage in these environments may cause poor image quality.**

When using the projector under dusty or smoky conditions, dust may accumulate on a lens, LCD panels, or optical elements inside the projector degrading the quality of a projected image. When the symptoms above are noticed, contact your authorized dealer or service station for proper cleaning.

## Resetting the Filter Counter

Be sure to reset the Filter counter after cleaning or replacing the filter.

- 1** Press the MENU button to display the On-Screen Menu. Use the Point ◀▶ buttons to move the red frame pointer to the Setting Menu icon.
- 2** Use the Point ▲▼ buttons to move the red frame pointer to Filter counter and then press the SELECT button. A dialog box appears showing the total accumulated time of the filter use, a timer setting option, and the reset option. Select Reset and the "Filter counter Reset?" appears. Select [Yes] to continue.
- 3** Another confirmation dialog box appears, select [Yes] to reset the Filter counter.

### Filter counter

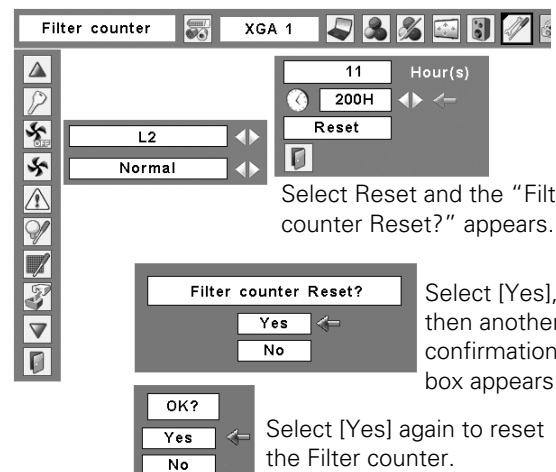

### **Slide Shutter**

Slide Shutter is provided to protect the surface of the lens against scratches and dirt. When you are not using the projector, close the Slide Shutter.

To open or close, use the Slide Shutter Lever on the top of the cabinet.

Do not close the shutter when the projection lamp is on.

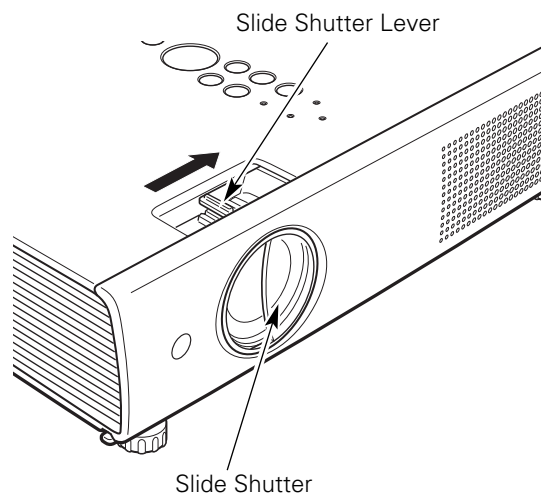

### **Cleaning the Projection Lens**

Unplug the AC power cord before cleaning.

Gently wipe the projection lens with a cleaning cloth that contains a small amount of non-abrasive camera lens cleaner, or use a lens cleaning paper or commercially available air blower to clean the lens.

Avoid using an excessive amount of cleaner. Abrasive cleaners, solvents, or other harsh chemicals might scratch the surface of the lens.

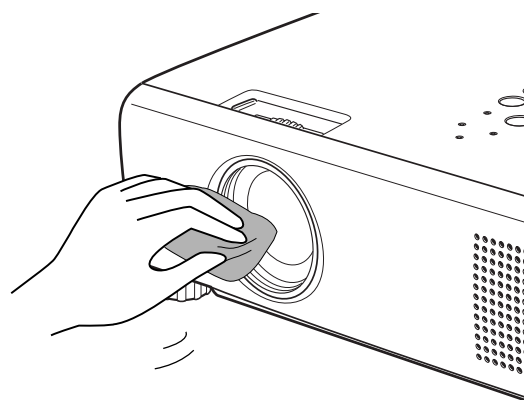

### **Cleaning the Projector Cabinet**

Unplug the AC power cord before cleaning.

Gently wipe the projector body with a soft dry cleaning cloth. When the cabinet is heavily soiled, use a small amount of mild detergent and finish with a soft dry cleaning cloth. Avoid using an excessive amount of cleaner. Abrasive cleaners, solvents, or other harsh chemicals might scratch the surface of the cabinet.

When the projector is not in use, put the projector in an appropriate carrying case to protect it from dust and scratches.

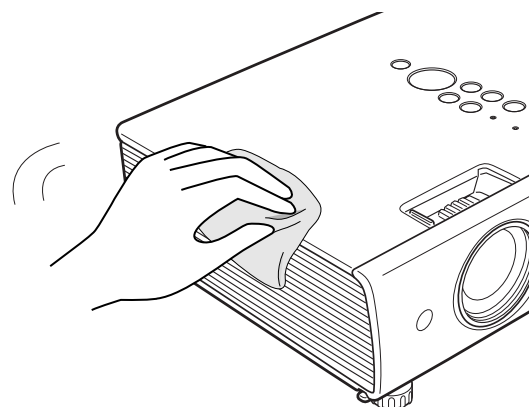



## Lamp Replacement

When the projection lamp of the projector reaches its end of life, the Lamp replacement icon appears on the screen and LAMP REPLACE indicator lights yellow. Replace the lamp with a new one promptly. The timing when the LAMP REPLACE indicator should light is depending on the lamp mode.

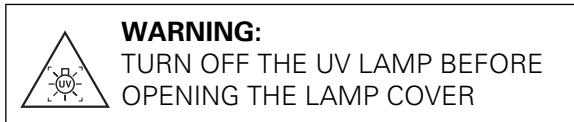

### Top Control

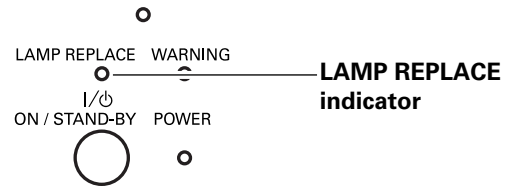

Lamp replacement



Lamp replacement icon

#### ✓Note:

- The Lamp replacement icon will not appear when the Display function is set to "Off" (p.48), during "Freeze" (p.28), or "No show" (p.29).



## CAUTION

Allow a projector to cool for at least 45 minutes before you open the Lamp cover. The inside of the projector can become very hot.



## CAUTION

For continued safety, replace with a lamp of the same type. Do not drop a lamp or touch a glass bulb! The glass can shatter and may cause injury.

Follow these steps to replace the lamp.

- 1** Turn off the projector and unplug the AC power cord. Let the projector cool for at least 45 minutes.
- 2** Remove the screw and open the lamp cover.
- 3** Remove the two (2) screws that secure the lamp. Lift the lamp out of the projector by using the handle.
- 4** Replace the lamp with a new one and secure the two (2) screws. Make sure that the lamp is set properly. Close the lamp cover and secure the screw.
- 5** Connect the AC power cord to the projector and turn on the projector.
- 6** **Reset the lamp counter.**  
See "Resetting the Lamp Counter" on the next page.

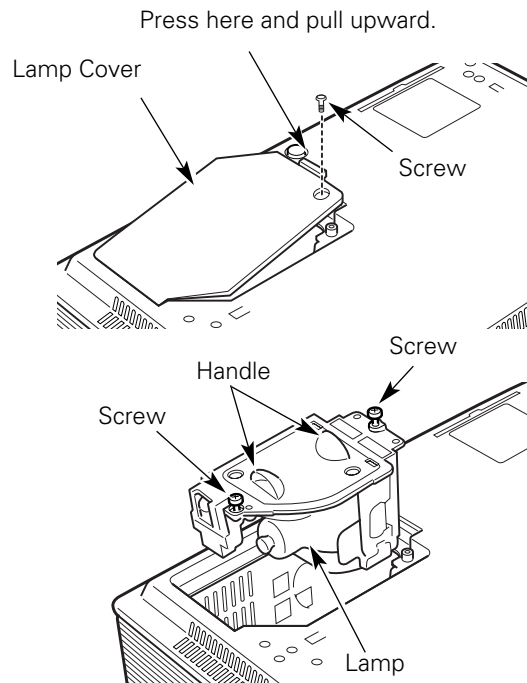

### ORDER REPLACEMENT LAMP

Replacement lamp can be ordered through your dealer. When ordering a projection lamp, give the following information to the dealer.

- **Model No. of your projector** : PLC-XU111/PLC-XU111K
- **Replacement Lamp Type No.** : POA-LMP11  
(Service Parts No. 610 333 9740)

### Resetting the Lamp Counter

Be sure to reset the Lamp counter after the lamp is replaced. When the Lamp counter is reset, the LAMP REPLACE indicator stops lighting and the Lamp replacement icon disappears.

- 1 Press the MENU button to display the On-Screen Menu. Use the Point ◀▶ buttons to move the red frame pointer to the Setting Menu icon.
- 2 Use the Point ▲▼ buttons to move the red frame pointer to Lamp counter and then press the SELECT button. A dialog box appears showing the total accumulated time of the lamp usage and the reset option. Select Reset and the "Lamp replacement counter Reset?" appears. Select [Yes] to continue.
- 3 Another confirmation dialog box appears, select [Yes] to reset the Lamp counter.

✓ **Note:**

- Do not reset the Lamp counter without implementing lamp replacement. Be sure to reset the Lamp counter only after replacing the lamp.

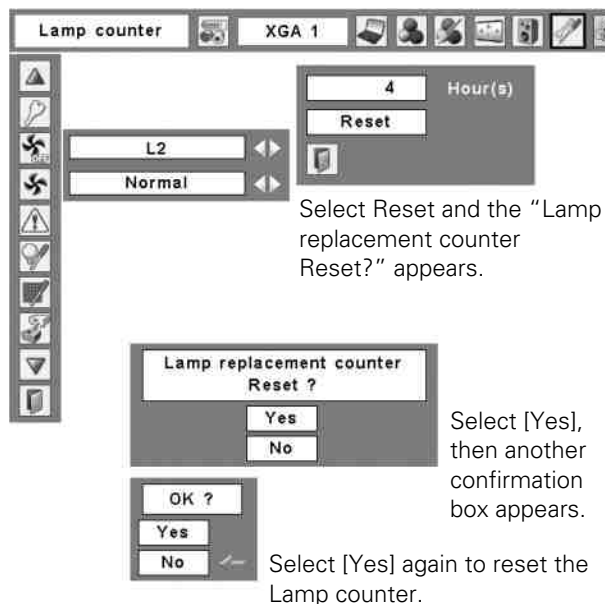

### LAMP HANDLING PRECAUTIONS

This projector uses a high-pressure lamp which must be handled carefully and properly. Improper handling may result in accidents, injury, or create a fire hazard.

- Lamp life may differ from lamp to lamp and according to the environment of use. There is no guarantee of the same life for each lamp. Some lamps may fail or terminate their life in a shorter period of time than other similar lamps.
- If the projector indicates that the lamp should be replaced, i.e., if the LAMP REPLACE indicator lights up, replace the lamp with a new one IMMEDIATELY after the projector has cooled down. (Follow carefully the instructions in the Lamp Replacement section of this manual.) Continuous use of the lamp with the LAMP REPLACE indicator lighted may increase the risk of lamp explosion.
- A Lamp may explode as a result of vibration, shock or degradation as a result of hours of use as its lifetime draws to an end. Risk of explosion may differ according to the environment or conditions in which the projector and lamp are being used.

#### IF A LAMP EXPLODES, THE FOLLOWING SAFETY PRECAUTIONS SHOULD BE TAKEN.

If a lamp explodes, disconnect the projector's AC plug from the AC outlet immediately. Contact an authorized service station for a checkup of the unit and replacement of the lamp. Additionally, check carefully to ensure that there are no broken shards or pieces of glass around the projector or coming out from the cooling air circulation holes. Any broken shards found should be cleaned up carefully. No one should check the inside of the projector except those who are authorized trained technicians and who are familiar with projector service. Inappropriate attempts to service the unit by anyone, especially those who are not appropriately trained to do so, may result in an accident or injury caused by pieces of broken glass.

# Appendix

## Troubleshooting

Before calling your dealer or service center for assistance, check the items below once again.

- Make sure you have properly connected the projector to peripheral equipment as described on pages 19–21.
- Make sure all equipment is connected to AC outlet and the power is turned on.
- When the projector does not project an image from the connected computer, restart the computer.

---

**Problem:**

– Solutions

---

**No power**

- Plug the power cord of the projector into the AC outlet.
  - See if the POWER indicator lights red.
  - Wait 90-120 seconds after the projector is turned off when turning the projector back on. The projector can be turned on after the POWER indicator turns red. See on page 22.
  - Check the WARNING indicator. If the WARNING indicator lights red, projector cannot be turned on. See on page 62.
  - Check the projection lamp. See page 65.
  - Unlock the Key lock function for the projector. See page 54.
- 

**Image is out of focus.**

- Adjust focus of the projector. See page 26.
  - Provide proper distance between the projector and the projection screen. See page 17.
  - Check the projection lens to see if it needs cleaning. See page 64.
  - Moving the projector from a cool to warm place may result in moisture condensation on the projection lens. In such cases, leave the projector off and wait until condensation evaporates.
- 

**No image**

- Check the connection between your computer or video equipment and the projector. See page 19–21.
  - See if the input signal is correctly output from your computer. Some laptop computers may need to change the setting for monitor output when connecting to a projector. See your computer's instruction manual for the setting.
  - It takes about 30 seconds to display an image after turning on the projector. See page 22.
  - See if the selected system is corresponding with your computer or video equipment. See pages 32, 42.
  - Select correct input source once again through menu operation. See pages 30–31, 40–41.
  - Make sure the temperature is not out of the specified Operating Temperature (41°F–95°F [5°C–35°C]).
- 

**Image is Left/Right reversed.  
Image is Top/Bottom reversed.**

- Check the Ceiling/Rear function. See page 51.
  - Check the Ceiling function. See page 51.
- 

**No sound**

- Check the audio cable connection from audio input source.
  - Adjust the audio source.
  - Press the Volume + button. See page 27.
  - Press the Mute button. See page 27.
  - Is the image projected? You will hear the sound only when the image is projected.
-

***Some displays are not seen during the operation.***

- Check the Display function. See page 48.

***PIN code dialog box appears at start-up.***

- PIN code lock is being set. Enter a PIN code (the “1234” or numbers you have set). See pages 22, 54–55.

***The Remote Control does not work.***

- Check the batteries.
- Make sure no obstruction is between the projector and remote control.
- Make sure you are not too far from the projector when using the remote control. Maximum operating range is 16.4' (5 m).
- Make sure the code of the remote control is conformed to the projector's code. See page 53.
- Unlock the Key lock function for the remote control function. See page 54.
- Make sure “ALL-OFF” switch on the remote control is set to “ON.” See page 13.

***Alarm does not stop ringing.***

- Connect the AC power cord to the AC outlet. (Alarm will not stop ringing when the alarm goes off while trying to remove the rechargeable battery cover.)

***Warning mode is not turned on.***

- If you cannot hear the bleeping sound when you press the Alarm buttons, you are not pressing the buttons correctly. Try to set the Alarm setting again.

**WARNING :**

**High voltages are used to operate this projector. Do not attempt to open the cabinet.**

If problems still persist after following all operating instructions, contact the dealer where you purchased the projector or the service center. Specify the model number and explain about the problem. We will advise you how to obtain service.

 The CE Mark is a Directive conformity mark of the European Community (EC).

 **UL US LISTED**

This symbol on the nameplate means the product is Listed by Underwriters Laboratories Inc. It is designed and manufactured to meet rigid U.L. safety standards against risk of fire, casualty and electrical hazards.



Pixelworks ICs used.

## Menu Tree

### Computer Input/Video Input

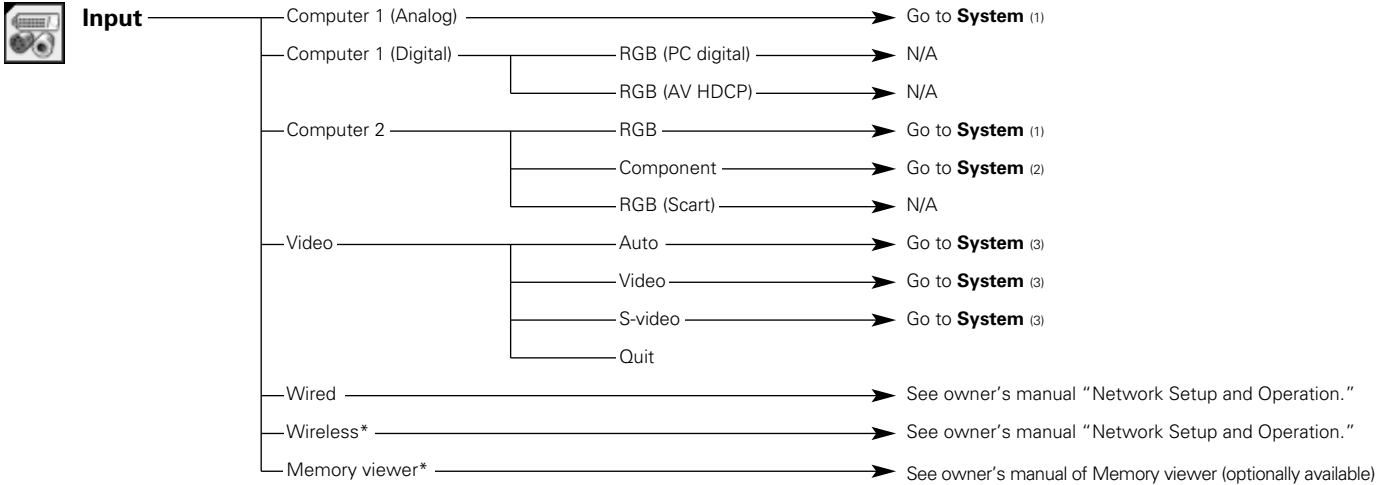

N/A .....not applicable  
 \* .....The menu will be displayed when connecting device for the input source.

### Sound

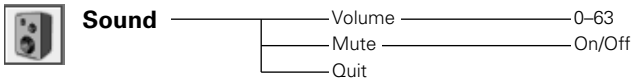

### Computer Input

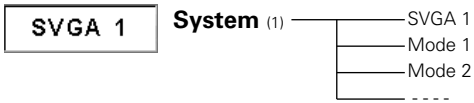

\*Systems displayed in the System Menu vary depending on an input signal.

### PC Adjust

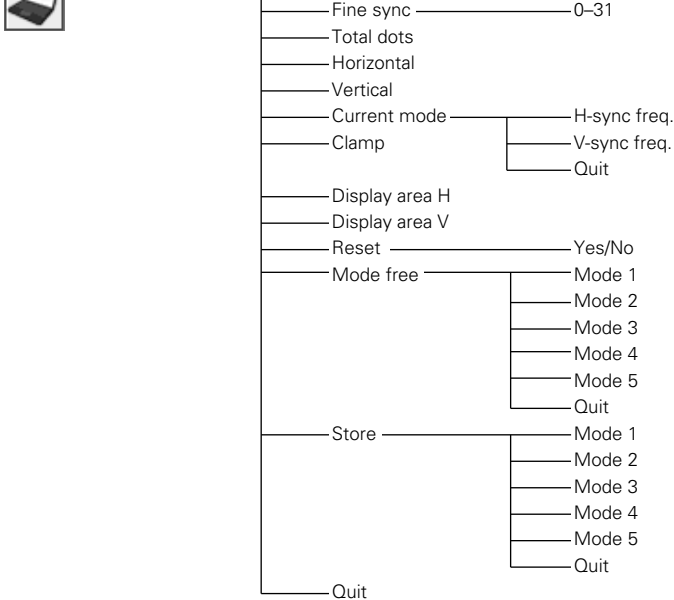

### Image Select

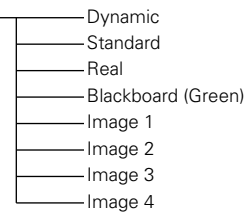

### Image Adjust

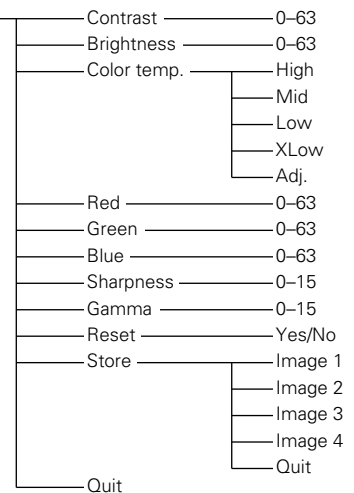

### Screen

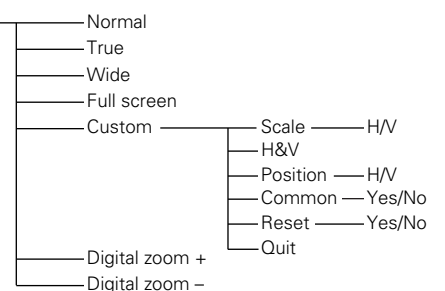

## Video Input



### System (2)

- Auto
- 1080i
- 1035i
- 720p
- 575p
- 480p
- 575i
- 480i



### System (3)

- Auto
- PAL
- SECAM
- NTSC
- NTSC 4.43
- PAL-M
- PAL-N



### Image Select

- Dynamic
- Standard
- Cinema
- Blackboard (Green)
- Image 1
- Image 2
- Image 3
- Image 4



### Image Adjust

- Contrast — 0-63
- Brightness — 0-63
- Color — 0-63
- Tint — 0-63
- Color temp.
  - High
  - Mid
  - Low
  - XLow
  - Adj.
- Red — 0-63
- Green — 0-63
- Blue — 0-63
- Sharpness — 0-15
- Gamma — 0-15
- Noise reduction
  - Off
  - L1
  - L2
- Progressive
  - Off
  - L1
  - L2
  - Film
- Reset — Yes/No
- Store
  - Image 1
  - Image 2
  - Image 3
  - Image 4
  - Quit
- Quit



### Screen

- Normal
- Wide
- Custom
  - Scale — H/V
  - H&V
  - Position — H/V
  - Common — Yes/No
  - Reset — Yes/No
  - Quit

## Setting





























### Setting

- Language — 16 languages provided.
  - Quit
- Auto setup
  - Auto PC adj.
    - On/Off
  - Auto keystone
    - Auto
    - Manual
    - Off
- Keystone — Store/Reset
- Blue back — On/Off
- Display — On/Countdown off/Off
- Logo — Logo select
  - Off
  - Default
  - User
- Capture
  - Yes/No
- Logo PIN code lock
  - On/Off
  - Logo PIN code change
  - Quit
- Quit
- Ceiling — On/Off
- Rear — On/Off
- Standby mode — Eco/Normal
- Power management
  - Off
  - Ready
  - Shut down
  - Timer (1-30 Min.)
  - Quit
- On start — On/Off
- Lamp control — Auto/High/Normal/Eco
- Pointer — Spotlight/Pointer
  - Quit
- Remote control — Code 1-Code 8
- Security — Key lock
  - Off
  - Projector
  - Remote control
  - Quit
- PIN code lock
  - Off/On1/On2
  - PIN code change
  - Quit
- Alarm
  - Off
  - Battery charge — Off/Auto
  - Alarm volume — Small/Medium/Large
  - Sensitivity — Low/Medium/High
  - Ringing time — 10 seconds/60 seconds/Long time
  - Quit
  - On
- Quit
- Fan — L1/L2
- Fan control — Normal/Max
- Warning log
- Lamp counter
  - Hour(s)
  - Reset — Yes/No
  - Quit
- Filter counter
  - Hour(s)
  - Off/100H/200H/300H
  - Reset — Yes/No
  - Quit
- Factory default — Yes/No
- Quit

## Indicators and Projector Condition

Check the indicators for projector condition.

For Alarm indicator, see page 58

Indicators			Projector Condition
POWER red/green	WARNING red	LAMP REPLACE yellow	
			The projector is off. (The AC power cord is unplugged.)
			The projector is in stand-by mode. Press the ON/STAND-BY button to turn on the projector.
			The projector is operating normally.
			The projector is preparing for stand-by or the projection lamp is being cooled down. The projector cannot be turned on until cooling is completed and the POWER indicator stops blinking.
			The projector is in the Power management mode.
			The temperature inside the projector is abnormally high. The projector cannot be turned on. When the projector is cooled down enough and the temperature returns to normal, the POWER indicator stops blinking and the projector can be turned on. (The WARNING indicator keeps blinking.) Check and clean the filter.
			The projector has been cooled down enough and the temperature returns to normal. When turning on the projector, the WARNING indicator stops blinking. Check and clean the air filter.
			The projector detects an abnormal condition and cannot be turned on. Unplug the AC power cord and plug it again to turn on the projector. If the projector is turned off again, unplug the AC power cord and contact the dealer or the service center for service and checkup. Do not leave the projector on. It may cause an electric shock or a fire hazard.
			The projector's Network or Memory viewer function is in an abnormal condition.

 ●●● green.

 ●●● red

 ●●● off

 ●●● blinks green.

 ●●● blinks red.

When the projection lamp reaches its end of life, the LAMP REPLACE indicator lights yellow. When this indicator lights yellow, replace the projection lamp with a new one promptly. Reset the lamp replacement counter after replacing the lamp. See pages 65–66.

## Compatible Computer Specifications

Basically this projector can accept the signal from all computers with the V-, H-Frequency mentioned below and less than 140 MHz of Dot Clock for analog signal and 110 MHz of Dot Clock for digital signal.

When selecting these modes, PC adjustment can be limited.

ON-SCREEN DISPLAY	RESOLUTION	H-Freq. (KHz)	V-Freq. (Hz)	ON-SCREEN DISPLAY	RESOLUTION	H-Freq. (KHz)	V-Freq. (Hz)
VGA 1	640 x 480	31.47	59.88	SXGA 1	1152 x 864	64.20	70.40
VGA 2	720 x 400	31.47	70.09	SXGA 2	1280 x 1024	62.50	58.60
VGA 3	640 x 400	31.47	70.09	SXGA 3	1280 x 1024	63.90	60.00
VGA 4	640 x 480	37.86	74.38	SXGA 4	1280 x 1024	63.34	59.98
VGA 5	640 x 480	37.86	72.81	SXGA 5	1280 x 1024	63.74	60.01
VGA 6	640 x 480	37.50	75.00	SXGA 6	1280 x 1024	71.69	67.19
VGA 7	640 x 480	43.269	85.00	SXGA 7	1280 x 1024	81.13	76.107
MAC LC13	640 x 480	34.97	66.60	SXGA 8	1280 x 1024	63.98	60.02
MAC 13	640 x 480	35.00	66.67	SXGA 9	1280 x 1024	79.976	75.025
480p	640 x 480	31.47	59.88	SXGA 10	1280 x 960	60.00	60.00
575p	768 x 575	31.25	50.00	SXGA 11	1152 x 900	61.20	65.20
480i	—	15.734	60.00 (Interlace)	SXGA 12	1152 x 900	71.40	75.60
575i	—	15.625	50.00 (Interlace)	SXGA 13	1280 x 1024	50.00	86.00 (Interlace)
SVGA 1	800 x 600	35.156	56.25	SXGA 14	1280 x 1024	50.00	94.00 (Interlace)
SVGA 2	800 x 600	37.88	60.32	SXGA 15	1280 x 1024	63.37	60.01
SVGA 3	800 x 600	46.875	75.00	SXGA 16	1280 x 1024	76.97	72.00
SVGA 4	800 x 600	53.674	85.06	SXGA 17	1152 x 900	61.85	66.00
SVGA 5	800 x 600	48.08	72.19	SXGA 18	1280 x 1024	46.43	86.70 (Interlace)
SVGA 6	800 x 600	37.90	61.03	SXGA 19	1280 x 1024	63.79	60.18
SVGA 7	800 x 600	34.50	55.38	SXGA 20	1280 x 1024	91.146	85.024
SVGA 8	800 x 600	38.00	60.51	SXGA+ 1	1400 x 1050	63.97	60.19
SVGA 9	800 x 600	38.60	60.31	SXGA+ 2	1400 x 1050	65.35	60.12
SVGA 10	800 x 600	32.70	51.09	SXGA+ 3	1400 x 1050	65.12	59.90
SVGA 11	800 x 600	38.00	60.51	MAC21	1152 x 870	68.68	75.06
MAC 16	832 x 624	49.72	74.55	MAC	1280 x 960	75.00	75.08
XGA 1	1024 x 768	48.36	60.00	MAC	1280 x 1024	80.00	75.08
XGA 2	1024 x 768	68.677	84.997	WXGA 1	1366 x 768	48.36	60.00
XGA 3	1024 x 768	60.023	75.03	WXGA 2	1360 x 768	47.70	60.00
XGA 4	1024 x 768	56.476	70.07	WXGA 3	1376 x 768	48.36	60.00
XGA 5	1024 x 768	60.31	74.92	WXGA 4	1360 x 768	56.16	72.00
XGA 6	1024 x 768	48.50	60.02	WXGA 6	1280 x 768	47.776	59.870
XGA 7	1024 x 768	44.00	54.58	WXGA 7	1280 x 768	60.289	74.893
XGA 8	1024 x 768	63.48	79.35	WXGA 8	1280 x 768	68.633	84.837
XGA 9	1024 x 768	36.00	87.17 (Interlace)	WXGA 9	1280 x 768	49.600	60.050
XGA 10	1024 x 768	62.04	77.07	UXGA 1	1600 x 1200	75.00	60.00
XGA 11	1024 x 768	61.00	75.70	UXGA 2	1600 x 1200	81.25	65.00
XGA 12	1024 x 768	35.522	86.96 (Interlace)	UXGA 3	1600 x 1200	87.5	70.00
XGA 13	1024 x 768	46.90	58.20	UXGA 4	1600 x 1200	93.75	75.00
XGA 14	1024 x 768	47.00	58.30	720p	1280 x 720	45.00	60.00
XGA 15	1024 x 768	58.03	72.00	1035i	1920 x 1035	33.75	60.00 (Interlace)
MAC 19	1024 x 768	60.24	75.08	1080i	1920 x 1080	33.75	60.00 (Interlace)
				1080i	1920 x 1080	28.125	50.00 (Interlace)



When the input signal is digital from DVI terminal, refer to the chart below.

ON-SCREEN DISPLAY	RESOLUTION	H-Freq. (KHz)	V-Freq. (Hz)	ON-SCREEN DISPLAY	RESOLUTION	H-Freq. (KHz)	V-Freq. (Hz)
D-VGA	640 x 480	31.47	59.94	D-SXGA1	1280 x 1024	63.98	60.02
D-480p	640 x 480	31.47	59.88	D-SXGA2	1280 x 1024	60.276	58.069
D-575p	768 x 575	31.25	50.00	D-SXGA+ 1	1400 x 1050	63.97	60.19
D-SVGA	800 x 600	37.879	60.32	D-720p	1280 x 720	45.00	60.00
D-XGA	1024 x 768	43.363	60.00	D-1035i	1920 x 1035	33.75	60.00 (Interface)
D-WXGA 1	1366 x 768	48.36	60.00	D-1080i	1920 x 1080	33.75	60.00 (Interface)
D-WXGA 2	1360 x 768	47.7	60.00	D-1080i	1920 x 1080	28.125	50.00 (Interface)
D-WXGA 3	1376 x 768	48.36	60.00				
D-WXGA 4	1360 x 768	56.160	72.000				
D-WXGA 5	1366 x 768	46.500	50.000				
D-WXGA 6	1280 x 768	47.776	59.870				
D-WXGA 7	1280 x 768	60.289	74.893				
D-WXGA 9	1280 x 800	49.600	60.050				

**✓Note:**

- When the input signal is D-SXGA 1, D-SXGA 2, or D-SXGA 3, images may not be displayed properly depending on computers.

## Technical Specifications

### Mechanical Information

Projector Type	Multi-media Projector
Dimensions (W x H x D)	13.15" x 3.07" x 9.13" (334 mm x 78 mm x 232 mm) (Not including adjustable feet)
Net Weight	7.7 lbs (3.5 kg)
Feet Adjustment	0° to approx. 9.0°

### Panel Resolution

LCD Panel System	0.8" TFT Active Matrix type, 3 panels
Panel Resolution	1,024 x 768 dots
Number of Pixels	2,359,296 (1,024 x 768 x 3 panels)

### Signal Compatibility

Color System	PAL, SECAM, NTSC, NTSC4.43, PAL-M, and PAL-N
High Definition TV Signal	480i, 480p, 575i, 575p, 720p, 1035i, and 1080i
Scanning Frequency	H-sync. 15 kHz–100 kHz, V-sync. 50–100 Hz

### Optical Information

Projection Image Size (Diagonal)	Adjustable from 33" to 300"
Throw Distance	4.3'–32.8' (1.3 m–10.0 m)
Projection Lens	F1.7–2.1 lens with f26.7 mm–32.0 mm with manual zoom and focus
Projection Lamp	275 W

### Interface

Video Input Jack	RCA Type x 1
S-video Input Jack	Mini DIN 4 pin x 1
Audio Input Jacks	RCA Type x 2
Computer Input 1/DVI-I Input Terminal	DVI-I Terminal X 1
Computer Input 2/Component Input Terminal	Analog RGB (Mini D-sub 15 pin) Terminal x 1
Monitor Output Terminal	Analog RGB (Mini D-sub 15 pin) Terminal x 1
Computer/Component Audio Input Jack	Mini Jack (stereo) x 1
Service Port Connector	Mini DIN 8 pin x 1
USB Connector	USB Series A connector x 1/USB Series B connector x 1
Audio Output Jack	Mini Jack (stereo) x 1 (variable)
LAN Connection Terminal	100 Base-TX (100 Mbps)/10 Base-T (10Mbps), RJ45

### Audio

Internal Audio Amp	1.0 W RMS
Built-in Speaker	1 speaker, ø1.1" (28 mm)

### Power

Voltage and Power Consumption	AC 100–120 V (4.9A Max. Ampere), 50/60 Hz (The U.S.A and Canada) AC 200–240 V (2.2A Max. Ampere), 50/60 Hz (Continental Europe and The U.K.)
-------------------------------	---

### Operating Environment

Operating Temperature	41°F–95°F (5 °C–35 °C)
Storage Temperature	14°F–140°F (-10°C–60 °C)

### Remote Control

Battery	AAA or LR03 Type x 2
Operating Range	16.4' (5 m)/±30°
Dimensions	1.8" (W) x 1.0" (H) x 5.7" (D) (45 mm x 25 mm x 145 mm)
Net Weight	3.5 oz (99 g) (including batteries)
Laser Pointer	Class II Laser (Max. Output: 1 m W/Wave length: 640–660 nm)

### Built-In Battery (Antitheft Alarm)

SANYO Ni-MH BATTERY PACK 3.6V (Part No. 645 089 8587)
--

## Accessories

---

Owner's Manual (CD-ROM)  
 Quick Reference Guide  
 AC Power Cord  
 Remote Control and Batteries  
 VGA Cable  
 PIN Code Label  
 Alarm Label  
 Network Application (CD-ROM)  
 Soft Carrying Case  
 USB Wireless LAN Adapter

- The specifications are subject to change without notice.
- LCD panels are manufactured to the highest possible standards. Even though 99.99% of the pixels are effective, a tiny fraction of the pixels (0.01% or less) may be ineffective by the characteristics of the LCD panels.

## Optional Parts

The parts listed below are optionally available. When ordering those parts, specify the item name and Model No. to the sales dealer.

	<i>Model No.</i>
<b>COMPONENT-VGA Cable</b>	: POA-CA-COMPVGA
<b>SCART-VGA Cable</b>	: POA-CA-SCART
<b>Remote Control Cable (10 m)</b>	: KA-VC-RC10
<b>Remote Control Cable (30 m)</b>	: POA-CA-RC30
<b>VGA-Cable (10 m)</b>	: KA-MC-DB10
<b>USB Memory</b>	: POA-USB02 (This is used for Memory viewer operation.)

### **PJ Link Notice**

This projector is compliant with PJLink Standard Class 1 of JBMIA (Japan Business Machine and Information System Industries Association). This projector supports all commands defined by PJLink Class 1 and is verified conformance with PJLink Standard Class 1.

For PJ Link password, see page 49 on the owner's manual "Network Set-up and Operation."

Projector Input		PJLink Input	Parameter
Computer1 (Analog)		RGB 1	11
Computer1 (Digital)	RGB (PC digital)	DIGITAL 1	31
	RGB (AV HDCP)	DIGITAL 2	32
Computer2	RGB	RGB 2	12
	Component	RGB 3	13
	RGB (Scart)	RGB 4	14
Video	Auto	VIDEO 1	21
	Video	VIDEO 2	22
	S-video	VIDEO 3	23
Wired		NETWORK 1	51
Wireless		NETWORK 2	52
Memory viewer		STORAGE 1	41

PJLink is a registered trademark of JBMIA and pending trademark in some countries.



## Configurations of Terminals

### COMPUTER IN 2 /COMPONENT IN /MONITOR OUT (ANALOG)

Terminal: Analog RGB (Mini D-sub 15 pin)

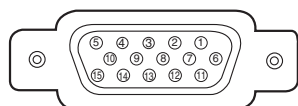

1	Red (R/Cr) Input/Output	9	5V
2	Green (G/Y) Input/Output	10	Ground (Vert.sync.)
3	Blue (B/Cb) Input/Output	11	Ground
4	---	12	DDC data
5	Ground (Horiz.sync.)	13	Horiz. sync. Input/Output (Composite H/V sync.)
6	Ground (Red)	14	Vert. sync.
7	Ground (Green)	15	DDC clock
8	Ground (Blue)		

### DVI-I TERMINAL (DIGITAL/ANALOG)

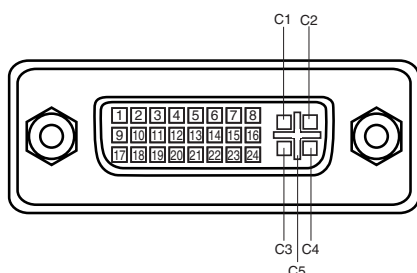

C1	Analog Red Input
C2	Analog Green Input
C3	Analog Blue Input
C4	Analog Horiz. sync
C5	Analog Ground (R/G/B)

1	T.M.D.S. Data2-	9	T.M.D.S. Data1-	17	T.M.D.S. Data0-
2	T.M.D.S. Data2+	10	T.M.D.S. Data1+	18	T.M.D.S. Data0+
3	T.M.D.S. Data2 Shield	11	T.M.D.S. Data1 Shield	19	T.M.D.S. Data0 Shield
4	No Connect	12	No Connect	20	No Connect
5	No Connect	13	No Connect	21	No Connect
6	DDC Clock	14	+5V Power	22	T.M.D.S. Clock Shield
7	DDC Data	15	Ground (for +5V)	23	T.M.D.S. Clock+
8	Analog Vert. sync	16	Hot Plug Detect	24	T.M.D.S. Clock-

### USB CONNECTOR (Series A)

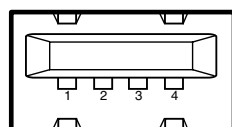

1	VCC(5V)
2	- DATA
3	+ DATA
4	Ground

### USB CONNECTOR (Series B)

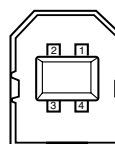

1	Vcc
2	- Data
3	+ Data
4	Ground

### LAN TERMINAL

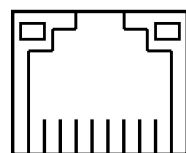

87654321

1	TX +	5	---
2	TX -	6	RX -
3	RX +	7	---
4	---	8	---

### SERVICE PORT CONNECTOR

Terminal : Mini DIN 8-PIN

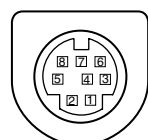

1	R X D	5	RTS/CTS
2	---	6	T X D
3	---	7	GND
4	GND	8	GND

## PIN Code Number Memo

Write down the PIN code number in the column below and keep it with this manual securely. If you forgot or lost the number and unable to operate the projector, contact the service station.

**PIN Code Lock No.**

--	--	--	--

Factory default set No: 1 2 3 4\*

**Logo PIN Code Lock No.**

--	--	--	--

Factory default set No: 4 3 2 1\*

**Alarm PIN Code No.**

--	--	--	--

Factory default set No: 1 1 1 1\*

\*Should the four-digit number be changed, the factory set number will be invalid.

While the projector is locked with the PIN code....

Put the label below (supplied) on in a prominent place of the projector's body while it is locked with a PIN code.



While the Antitheft alarm function is set....

Put the label below (supplied) on in a prominent place of the projector's body while the Antitheft alarm function is set.

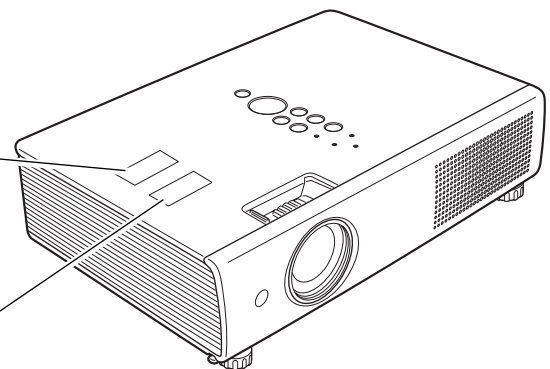

# Dimensions

Unit: inch (mm)

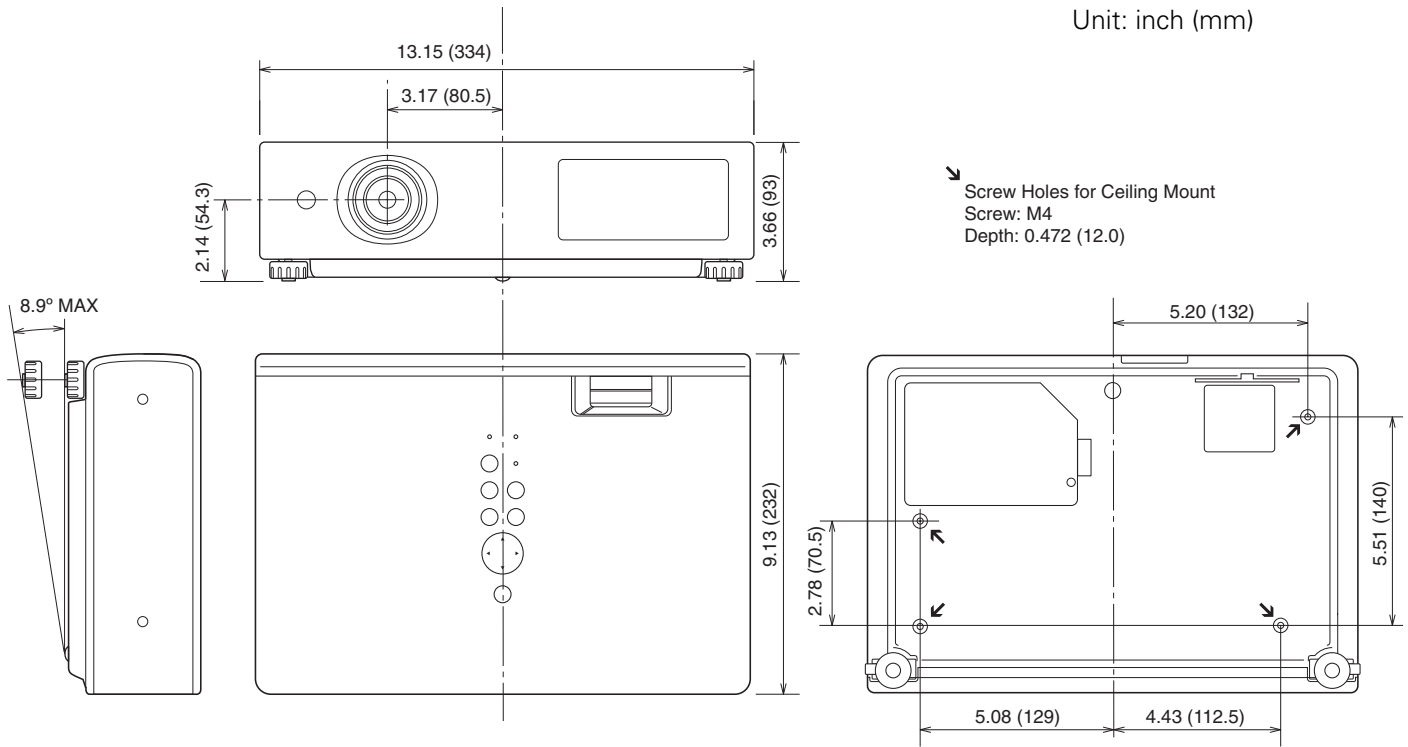



---

**SANYO Electric Co., Ltd.**

KM6AC



# Owner's Manual

## Network Set-up and Operation

Wired and Wireless Setting

Projector Controller

Network Viewer

Moderator Function

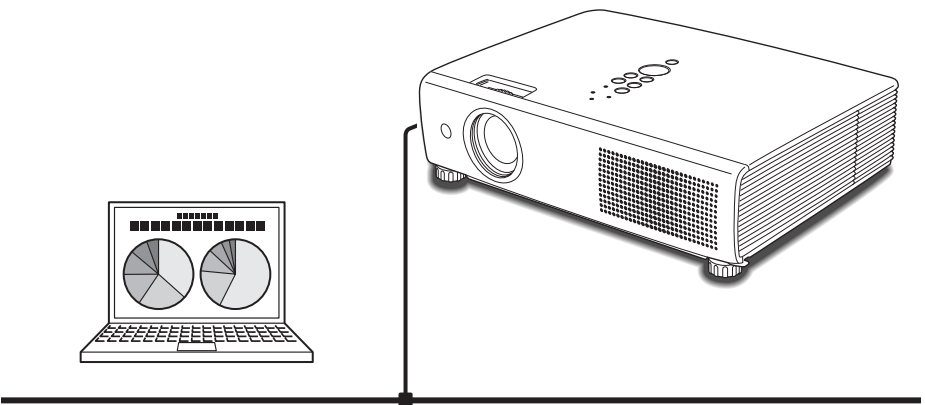

First, read the owner's manual of the projector to understand the projector's basic operation and the safety instructions.

The safety instructions in the owner's manuals should be followed.

# Compliance

---

## Federal Communication Commission Notice

This equipment has been tested and found to comply with the limits for a Class B digital device, pursuant to part 15 of the FCC Rules. These limits are designed to provide reasonable protection against harmful interference in a residential installation. This equipment generates, uses and can radiate radio frequency energy and, if not installed and used in accordance with the instructions, may cause harmful interference to radio communications. However, there is no guarantee that interference will not occur in a particular installation. If this equipment does cause harmful interference to radio or television reception, which can be determined by turning the equipment off and on, the user is encouraged to try to correct the interference by one or more of the following measures:

- Reorient or relocate the receiving antenna.
- Increase the separation between the equipment and receiver.
- Connect the equipment into an outlet on a circuit different from that to which the receiver is connected.
- Consult the dealer or an experienced radio/TV technician for help.

Use of shielded cable is required to comply with class B limits in Subpart B of Part 15 of FCC Rules.

Do not make any changes or modifications to the equipment unless otherwise specified in the instructions. If such changes or modifications should be made, you could be required to stop operation of the equipment.

Model Number	: PLC-XU111
Trade Name	: Sanyo
Responsible party	: SANYO FISHER COMPANY
Address	: 21605 Plummer Street, Chatsworth, California 91311
Telephone No.	: (818)998-7322

## For Canadian Users

This Class B digital apparatus complies with Canadian ICES-003.

Cet appareil numérique de la class B est conforme à la norme NMB-003 du Canada.

L'utilisation de ce dispositif est autorisée seulement aux conditions suivantes: (1) il ne doit pas produire de brouillage et (2) l'utilisateur du dispositif doit être prêt à accepter tout brouillage radioélectrique reçu, même si ce brouillage est susceptible de compromettre le fonctionnement du dispositif.

## CAUTION

Changes or modifications not expressly approved by the manufacturer could void the user's authority to operate the equipment.

## Exposure to radio frequency

This product uses a USB Wireless LAN Adapter to communicate with other devices using the 2.4 GHz ISM band. The radiated power output of this card is well below FCC radio frequency exposure limits. However, it is advised to maintain a minimum 20 cm separation between the product and user(s) or bystanders to minimize human exposure to the transmitted radio frequencies.

## For French Users

Restricted frequency band only channels 10 through 11 (2457MHz and 2462MHz respectively) may be used in France. License required for every installation, indoor and outdoor installations.

Please contact ART for procedure to follow. Do not use this USB Wireless LAN Adapter in the open air.

## Statement on EC Directive

Hereby, SANYO Electric Co., Ltd., declares that this USB Wireless LAN Adapter (XG-705A) is in compliance with the essential requirements and other relevant provisions of Directive 1999/5/EC.



The CE Mark is a Directive conformity mark of the European Community(EC).



The Alert Mark is a Directive conformity mark of the European Community.

# Safety Instructions

---



## CAUTION IN USING THE PROJECTOR VIA NETWORKS

- When you find a problem with the projector, remove the power cable immediately and inspect the unit. Using the projector with failure may cause fire or other accidents.
- If you remotely use the projector via networks, carry out a safety check regularly and take particular care to its environment. Incorrect installation may cause fire or other accidents.



## CAUTION IN USING NETWORK FUNCTION

- SANYO Electric Co., Ltd. assumes no responsibility for the loss or damage of data, or damage of the computer caused by using this projector. Making back-up copies of valuable data in your computer is recommended.

## Caution about Radio Wave

This unit operates in 2.4 GHz band, the same frequency band used for industrial, scientific, and medical equipment (such as pacemaker), as well as amateur radio stations.

Please read "Safety Instructions" section and make sure the following cautions.

1. Be sure that there are no other devices in the area that may use the same frequency band as Projector.
2. If any other devices are causing radio interferences, change the communication frequency channel or move to other location.

## Trademarks and Copyright

Microsoft, Windows, and Internet Explorer are either registered trademarks or trademarks of Microsoft Corporation in the United States and/or other countries.

Netscape Navigator and Netscape Communicator are registered trademarks or trademarks of Netscape Communications Corporation in the United States and other countries.

Pentium is a registered trademark of Intel Corp. in the United States.

Each name of corporation or product in this Owner's Manual is either a registered trademark or a trademark of its respective corporation.

## Notes

- The contents of this manual are subject to change without notice.
- You may not copy the printed materials accompanying with the software.
- We shall not be responsible for any damages caused by reliance on this manual.

# Table of Contents

---

Compliance.....	2
Safety Instructions.....	3
Table of Contents.....	4
<b>Operating Environment and Configuration .....</b>	<b>6</b>
Required Operating Environment for Computers .....	6
Network Specifications of the Projector .....	7
<b>1. About LAN Functions .....</b>	<b>9</b>
LAN Functions and the Features.....	10
Image Projecting System via LAN.....	10
Flow of Image Transfer .....	10
An Example of the Connection .....	11
LAN Connection Modes.....	12
<b>2. Setup Procedures .....</b>	<b>15</b>
Installing the Software .....	17
<b>3. Names and Functions of the Operation Screen .....</b>	<b>19</b>
Network Connection Standby Display.....	20
NetworkModule Client.....	21
NetworkModule Moderator .....	23
<b>4. Wired LAN Configurations.....</b>	<b>25</b>
Connecting to the LAN Line.....	26
Network Environment Settings.....	26
Setting Procedure.....	26
Confirming the Operation.....	28
User PIN Code / Wired Information / Wired Factory Default .....	30
Factory Default Setting of the Wired LAN .....	31
<b>5. Wireless LAN Configurations .....</b>	<b>33</b>
Attaching the USB Wireless LAN Adapter .....	34
Setting the Network Environment .....	34
Setting Procedures.....	34
Easy Setting .....	36
Setting Procedures.....	36
User PIN Code / Wireless Information / Wireless Factory Default.....	37
Wireless LAN Factory Default Settings.....	38
<b>6. Configurations with Browser .....</b>	<b>39</b>
Introduction.....	40
Browser Environment .....	40
Browser Configuration .....	40
Starting up the Browser.....	41
Information .....	42
Quick Setup.....	44

---

Advanced Setup .....	46
TCP/IP .....	46
Wireless Setting .....	47
E-mail.....	48
Admin Password .....	49
User PIN code .....	50
Moderator Login Password .....	51
Miscellaneous .....	52
Change Configuration Set .....	53
Restart.....	54
<b>7. Project the Image via the Networks .....</b>	<b>55</b>
<b>8. Use the Moderator Function .....</b>	<b>57</b>
Moderator Function.....	58
Preparation for Using the Moderator Function.....	59
Preparation Procedure for Using the Moderator Function .....	59
Setting the Moderator Function .....	60
Registration of the Moderator .....	60
Registration of the Clients (Participants) .....	61
Unregister from Moderator Status.....	62
How to Use the Moderator Function .....	62
Project the Client's Images .....	62
Stop Projecting the Client's Images .....	62
Easy Settings for Moderator Function .....	62
<b>9. How to Use Network Viewer.....</b>	<b>63</b>
The Mechanism of Network Viewer and the Flow of the Signal .....	64
Operation.....	65
Functional Conditions of FTP Server Which Provides Images .....	65
Projecting the Image.....	66
<b>10. How to Use the PJ Controller .....</b>	<b>73</b>
How to Operate .....	74
Initial Settings.....	75
E-mail Setting.....	76
Power & Status .....	78
Control.....	80
Multi Control .....	89
<b>11. Appendix .....</b>	<b>91</b>
Troubleshooting .....	92
Terminology .....	95
Setting up the IP address with "arp" + "ping" command .....	96
Configuring WEP security with the projector .....	97

# Operating Environment and Configuration

---

## Required Operating Environment for Computers

.....

When operating the projector via the networks, computers should meet the operating environment below.

OS	Microsoft Windows 98SE/Me or Microsoft Windows 2000 Professional or Microsoft Windows XP Home Edition/Professional	
CPU	Pentium III 600MHz or More (more than 2GHz is recommended)	
Memory	128MB or More	
Free HDD Space	10MB	
Screen Resolution	Required to support any of VGA (640 x 480), SVGA (800 x 600), XGA (1024 x 768), The color number should be either 16 byte (65536 colors) or 24/32 bit (16.77 million colors).	
Communication Protocol	TCP/IP	
Network Correspond	Wireless LAN	Correspond to IEEE802.11b/g
	Wired LAN	Correspond to 100BASE-TX (100Mbps) /10BASE-T (10Mbps)
Browser Application	Microsoft Internet Explorer Ver.4.0 or later Netscape Communications Netscape Communicator Ver.6.0 or later	

## Network Specifications of the Projector

### LAN Terminal

Data communication speed	100Base-TX (100Mbps)/10Base-T (10Mbps)
Protocol	TCP/IP

### USB Wireless LAN Adapter

Interface	Correspond to IEEE802.11b/g, USB 2.0/1.1
Communication Mode	AdHoc, Infrastructure
Data Transfer Speed	1/2/5.5/11Mbps (IEEE802.11b) 6/9/12/18/24/36/48/54Mbps (IEEE802.11g) When using AdHoc mode, only IEEE802.11b is usable.
Wireless Frequency (Channel)	2412MHz–2462MHz (CH1–CH11)
Modulation Form	IEEE802.11g OFDM 54/4Mbps 64QAM, 36/24Mbps 16QAM, 18/12Mbps QRSK, 9/6Mbps BPSK IEEE802.11b DSSS1 11/5Mbps CCK, 2Mbps DQPSK, 1Mbps DBPSK
Protocol	TCP/IP
Security	WEP 64 Bit/WEP 128Bit/WEP 152Bit, SSID, ESSID, LEAP
Service area	about 30 m (without disturbance) Differs according to the operating environment.
Operating Voltage	DC 5V
Environmental conditions	Operating temperature: 5–35°C Storage temperature/Humidity: -10–60°C/5–95%

### Compliance

Countries and Standards	JAPAN: VCCI ClassB, TELEC (Wireless)
	USA: FCC Part15 Subpart C (Wireless) FCC Part15 Subpart C, Class B
	Canada: IC RSS-210 (Wireless), IC ICES-003 ClassB
	Europe: R&TTE, EMC, LVD





## **1. About LAN Functions**

---

This chapter describes the features, the mechanism, and connection procedures of the LAN.

# 1. About LAN Functions

---

## LAN Functions and the Features

---

This product is loaded with a LAN network function which enables you to project an image on the computer through a projector via Network with dedicated software.

With the software, you can also manipulate the projecting image and the projector.

This software has functions below and you can use the projector under various network environments to meet the wide-ranging needs of the operation.

- Accept both Wired and Wireless LAN environment. When operating via Wireless LAN, there is no need for wire connection.
- Remove the burden of LAN settings. Easy LAN setting function is provided.
- One computer image can be projected up to 5 projectors simultaneously.
- Project the faithful computer image without any influence by the application.
- Remote function which allows you to operate the projector from a distance.
- Monitoring function for the projector operation.
- E-mail function which reports the operating status to your maintenance management.
- Network viewer function which remotely operates the image data on the server to project through the projector.
- Moderator function with which the moderator can project the image on the participants' computer screen at the meetings or the classes.
- Multi control function which can operate multiple projectors (up to 64) simultaneously.

## Image Projecting System via LAN

---

The images are projected through an image capturing system which helps to project the faithful computer images. With this system, you can use the product under various application environments despite the differences of application software.

### Flow of Image Transfer

1. Download the computer image with the dedicated software faithfully to the real image.
2. The downloaded data will be compressed to the digital signal and transferred to the projector via the LAN (Wired or Wireless). (One computer can operate up to 5 projectors simultaneously.)
3. Digital signal will be reproduced into RGB image signal and will be projected by the projector.

\* The image will be transferred to each projector. The time lag can occur between each projection.

CAUTION: This product does not correspond to the application with DirectX, MS-Office assistant, and video replay such as DVD.

## An Example of the Connection

The illustration below shows an example of the projection via the LAN.  
You can project the image on Computer (1) (Wired LAN connection), or Computer (2) (Wireless LAN connection) through the selected projector .

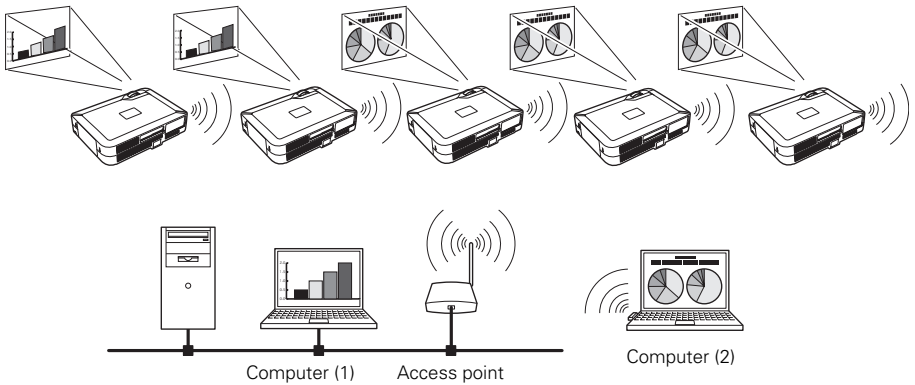

## LAN Connection Modes

Connection modes differ depending on the LAN and computer environments.  
Connect appropriately for each environment.

### ■ Wireless LAN, Infrastructure Communication Mode

Communicate over an access point between Wired LAN equipment and Wireless LAN equipment. Or, communicate over an access point among multiple Wireless LAN equipment. Wireless LAN equipment will select an access point to communicate SSID/ESSID modes. These communication modes are used when both Wireless LAN and Wired LAN are used in the same network environment.

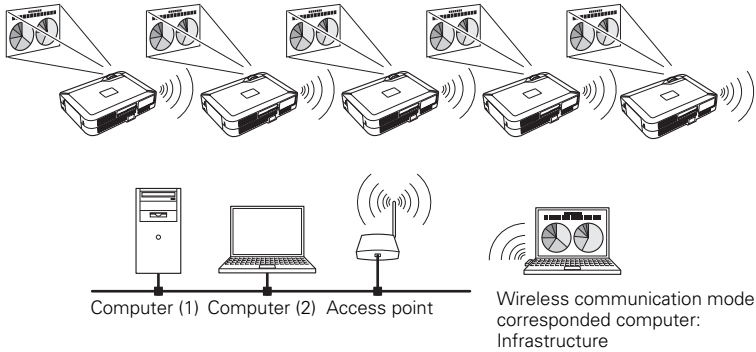

### ■ Wireless LAN, AdHoc 802.11b Communication Mode

Communication mode between Wireless LAN equipment.  
(Communication mode via SSID/ESSID)

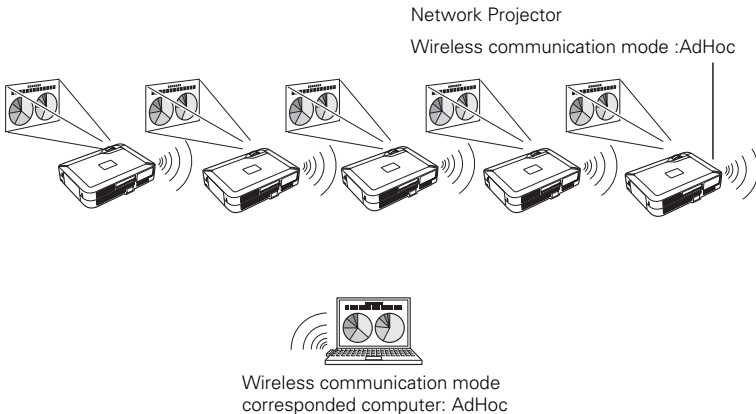

■ Wired LAN Communication Mode

Communicate via the LAN line.

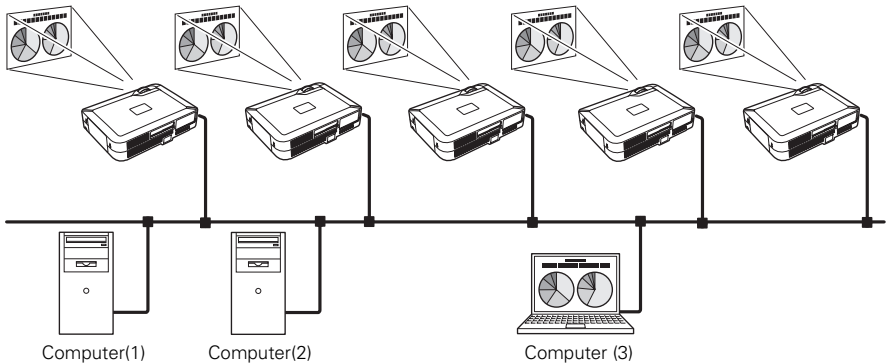

\* **Operate the computer mouse with the remote control.**

When the projector's remote control employs mouse operating function, you can operate the computer by the remote control which is provided with the projector. Use the remote control pointing to the projector. You do not need to connect the USB cable to operate the computer mouse.

(For details about the remote control operation, refer to the owner's manual of the projector.)



## 2. Setup Procedures

---

This chapter describes how to install the NetworkModule software and how to set up the networks.

## 2. Setup Procedures

---

To use the projector via the networks, follow the setup procedures below.

### **STEP 1 Install the software on computers.**



Install the software recorded in CD-ROM on each computer which will be operated. Read following pages of this chapter to install.

### **STEP 2 Select Wired LAN or Wireless LAN then connect the LAN and set the configuration.**



Decide depending on the LAN environment.

Wired LAN .....Refer to “4. Wired LAN Configurations” (pp.25–31).

Wireless LAN ...Refer to “5. Wireless LAN Configurations” (pp.33–38).

Detailed LAN configurations need to be done with a browser later.

First, complete the Wired or Wireless LAN connection between computers and projectors, then start browser configurations.

→ “6. Configurations with Browser” (pp.39–54).

### **STEP 3 Network Configuration has completed.**

Follow each chapter to project an image and operate the projector.

- Project an image on the computer
  - “7. Project the Image via the Networks” (pp.55–56).
- Project an image with the moderator function
  - “8. Use the Moderator Function” (pp.57–62).
- Project an image on a network server
  - “9. How to Use Network Viewer” (pp.63–71).
- Operate and manage the projector
  - “10.How to Use the PJ Controller” (pp.73–88).
  - Multi Control Function (pp.89–90).



## Installing the Software

Three pieces of software is recorded in the supplied CD-ROM.

### 1. Insert the CD-ROM into the drive.

The software will be activated automatically and “Software License” screen will be displayed. Read the license carefully and if you agree, check “Agree” then click “OK”.

When the screen is not displayed automatically, open “CD-ROM Drive” in “My computer” of your computer to activate “AutoRun. exe”. The software can be displayed both in Japanese and English. When the English version does not appear, open the English folder in the CD-ROM and double-click “AutoRun. exe” in it.

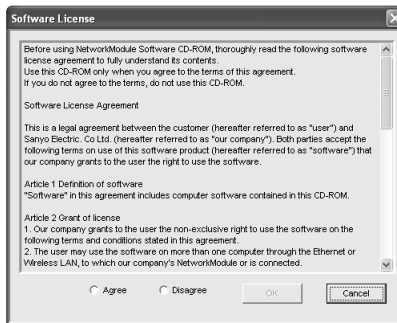

### 2. Main menu will be displayed on the screen.

Three software names will be shown on the left side of the screen.

Refer to the instructions below and select the most suitable software for you.

#### ■ When projecting via a selected computer which is connected to the LAN.

Install “NetworkModule Client.”

- (1) Click (Select) “NetworkModule Client” on the left side of the screen.
- (2) Click “Install NetworkModule Client” on the right side of the screen then move to the step (4).

\* By clicking the “Launch NetworkModule Client”, you can activate the software directly from the CD-ROM without installing the software into the computer.



## 2. Setup Procedures

---

■ When projecting with the Moderator function.

For details about Moderator function, refer to the “8. Use the Moderator Function.”

- (1) Install “NetworkModule Client” into each client’s (participants except for the moderator) computers. For installation, refer to “■ When projecting via a selected computer which is connected to the LAN” (p.17).
- (2) Click (Select) “NetworkModule Moderator” on the left side of the screen.
- (3) Click “Install NetworkModule Moderator”.

\* By clicking the “Launch NetworkModule Moderator”, you can activate the software directly from the CD-ROM without installing the software into the computer.

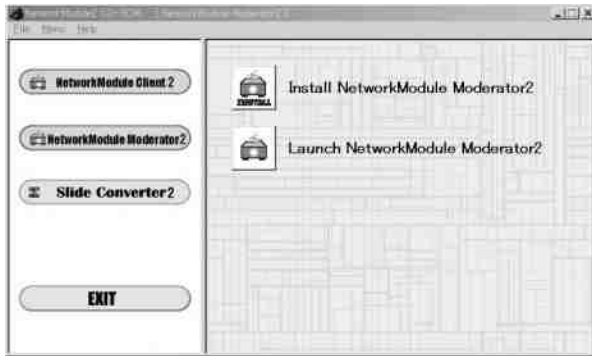

- (4) Install each software with following the instructions on the installation screen.
- (5) After the installation, the start-up menu will be displayed or the program icon will be added on the screen.
- (6) Activate the program to confirm the installation. When the program is activated, the operation screen will appear.

Refer to “3. Names and Functions of the Operation Screen” (pp.19–23) to operate each program screen.

To uninstall (delete) each program, activate the uninstall program in the application start menu.

## **3. Names and Functions of the Operation Screen**

---

This chapter describes the functions of each part of the operation screen.

# 3. Names and Functions of the Operation Screen

## Network Connection Standby Display

Select projector input either “Wired” or “Wireless” and the Network connection standby display will appear. Network environment will be shown on the screen. With this screen, you can confirm that the network connection is whether “Wired” or “Wireless”, or network environment of the projector when setting the connection.

After selecting “Wired” or “Wireless”, the “Please wait...” message will appear and then change into “Ready for use” message to show the network is ready to project. While the “Please wait...” message is showing, you cannot operate the projector.

You can select to display or not to display the Status bar (shows network environment) from “6. Configurations with Browser” → “Advanced Setup” → “Miscellaneous” (p.52).

Network Connection Standby Display  
(\*The screen on the right is for the Wireless LAN setting)

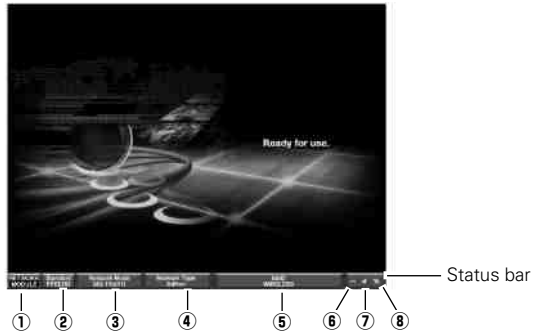

### ① NETWORKMODULE

“NETWORKMODULE” is the projector on the networks.

### ② The lower stand numbers show last 6 characters of a MAC address.

### ③ Display the Network Mode.

Auto (10/100M) is for Wired mode, 802.11b(11)/802.11g(11) is for Wireless mode.

### ④ Display the Network Type.

“Wired” for Wired mode, “AdHoc” or “Infrastructure” for Wireless mode.

### ⑤ SSID (Only for Wireless LAN)

Display the Wireless LAN ID which is set on the projector.

### ⑥ Packet receive display

Display the communication status of the projector.

When the display is blinking, the projector is properly connecting with the network.

When the display is not blinking, the projector is not connecting to the network.

### ⑦ Display whether the WEP (Encryption) is effective or ineffective.

The unlocked display means not encrypted, the locked display means encrypted.

(For Wired LAN, unlocked illustration will appear.)

### ⑧ Display the signal level.

Display the signal level of the Wired and Wireless. When the signal level is strong, there will be more vertical lines and the signal level is low, there will be less vertical lines.

## NetworkModule Client

This software is to project the computer screen via the networks.

To use the moderator function, install this software into each participant's (except for the moderator) computers.

Activate "NetworkModule Client" from the application start menu or the shortcut on the desk top, then following screen will appear. Then the program will start.

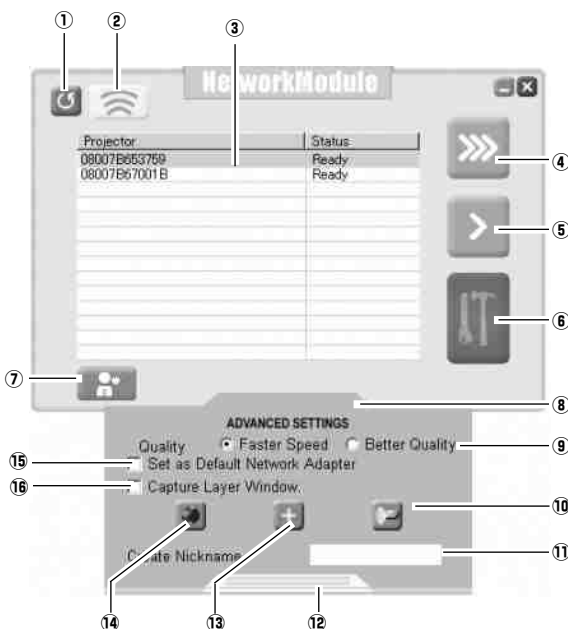

### Parts Names and Functions of the Screen

#### ① Refresh List button

Search the projector connected to the networks.

#### ② Locator button

Click the button after selecting a projector from the Network Projector List, the operated computer's nickname will be displayed on the upper part of the projected screen for a certain period. With this function, you can identify each projector.

#### ③ Network Projector List

Display all the projectors connected to the networks.

Show unoccupied projector as "Ready" and occupied projector as "In-use". When registered in a moderator's group, the projector is shown in pink characters.

### 3.Names and Functions of the Operation Screen

---

#### ④ Real time Capture button

Capture (Project) the computer screen in real time. After capturing, the button will change into the Stop Capture button. Click the Stop Capture button, then the projection will stop and the screen will disappear.

#### ⑤ One-shot Capture button

Copy and capture (project) the computer screen without modification. After completing the image transmission, the communication will stop and you can operate other functions.

#### ⑥ Easy Setting button

Configure the Wireless LAN settings just clicking this button. (The settings will be stored as AdHoc system) For details, refer to “5. Wireless LAN Configurations” → “Easy Setting.” (pp.36–37).

#### ⑦ Join the moderated session button

Enter the moderator’s group which is selected in the Network Projector List.

### Advanced Settings

#### ⑧ Advanced Settings button\*

Display the Advanced Settings.

#### ⑨ Quality selection

Select the speed and picture quality of the screen to capture.

Faster Speed —— Screen capturing will be speedy but the picture quality will be lower.

Better Quality—— Screen capturing will be slower but the picture quality will be better.

#### ⑩ PJ Controller/Multi control button

Start up the operation screen of the projector. Refer to “10. How to Use the PJ Controller” (pp.73–90).

#### ⑪ Create Nickname box

Create a nickname for each participant. When using moderator function, each computer’s nickname (up to 16 characters) will be displayed on the client list of the moderator’s screen allowing moderators to recognize the participants.

#### ⑫ Close button

Close Advanced Settings. (After closing the Advanced Settings menu, the settings you have made in ⑨ ⑪ ⑮ will be effective.)

#### ⑬ Add NetworkModule button

When connecting the projector which is not displayed on the “Network Projector List”, because it is separated by the router, click the button to set the connection. Refer to “4. Wired LAN Configurations” → “Confirming the Operation” (pp.28–29).

#### ⑭ Configure NetworkModule button

For setting the networks with the browser. Refer to “6. Configurations with Browser” (pp.39–54).

#### ⑮ Set as Default Network Adapter box

When using multiple network adapters with a computer, check here then the selected adapter will always be used with the software. After exiting the software, the selected adapter will be cancelled.

⑯ Check here when projecting layer window application pictures (Windows only). This function may affect some computer functions and, if so, please remove the checkmark.

\*The ⑧ ⑪ ⑮ ⑯ settings you have made in ⑧ Advanced settings will not be effective until closing the menu screen with ⑫ Close button.

## NetworkModule Moderator

When using the moderator function, install the software on the moderator's computer. The function is the same as "NetworkModule Client" and on top of it, the moderator function is added.

Activate "NetworkModule Moderator" from the application start menu or the shortcut on the desk top, then following screen will appear. Then the program will start.

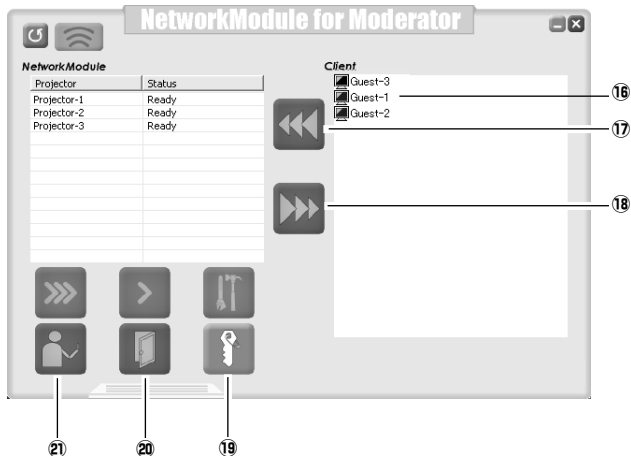

### Parts Names and Functions of the Screen

Refer to "NetworkModule Client" (pp.21–22) about functions which are not written below.

#### 16 Moderator Client List Screen

Clients (participants) who joined the moderator's group will be shown. The moderator selects one of the participants from the list to project his/her computer screen.

When the clients have nicknames, the names will be shown.

#### 17 Start Remote Capture button

Start capturing the image of the participants and send it to the projector.

The image will be sent in real time.

#### 18 Stop Remote Capture button

Stop capturing the image of the participants.

#### 19 Set Session Password

Set or modify the Session Password.

#### 20 Exit moderator status button

Unregister the moderator.

#### 21 Moderator login button

Register the computer user as a moderator.





## 4. Wired LAN Configurations

---

This chapter describes the preparation for Wired LAN setting with projectors and how to set the LAN environment.

# 4. Wired LAN Configurations

Setting procedures and contents differ depending on the LAN installation location. When installing, consult your system administrator to set up the LAN appropriately.

## Connecting to the LAN Line

Connect the LAN cable to the LAN connection terminal of the projector.

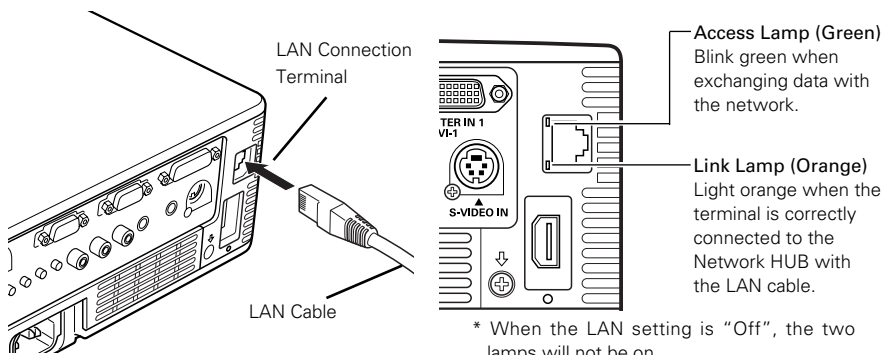

## Network Environment Settings

Set the Wired LAN network through the projector menu.

Detailed network settings will be made with browser. Refer to “6. Configurations with Browser” (pp.39–54).

First, complete the settings described in this chapter before performing steps in “6. Configurations with Browser.”

### Setting Procedure

1. Turn on the projector and select “Wired” from the input menu of the projector.  
The projector’s Link Lamp will be on and the Access Lamp will start to blink. If the “Wired setting” is “Off”, it will not blink. Follow step 2 and 3 to blink the lamp.
2. Select “Wired Setting” in the projector menu, and press the SELECT button.  
Select similar LAN environment among LAN1, 2 and 3 with the Point ◀▶ buttons. (LAN1, 2, and 3 are the factory default setting environments. You can select three different environment among setting LAN1–3. For each setting, refer to the chart on page 31.)  
When selecting “Off” in the “Wired setting”, the LAN connection will be cut off. Use the function when disconnecting the projector from the network.
3. Press the Point button then the “Please wait...” message will appear and switching operation will start. Switching will take a while and after completing the operation, the “Ready for use” message will appear. During the switching period, the projector cannot be operated.

4. Press the SELECT button.

LAN setting screen will appear and selected LAN settings will be displayed. Adjust each item to the setting environment. Consult your system administrator about the detailed settings.

Adjust the figures with the Point ▲▼ buttons and move among the items with the Point ◀▶ buttons.

5. After completing all the settings, select “Set” and press the SELECT button. Now, all procedures has done. To cancel the adjusted settings, select the CANCEL button before clicking the SET button.

To confirm whether the settings are correct, follow the procedures from the next page.

You can confirm the LAN settings you have made from “Wired Information” (p.30). As in the case that the LAN cannot be connected, see this screen.

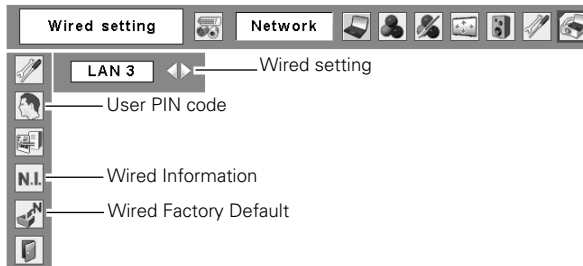

Wired LAN setting screen (Example)

LAN1		Wired setting			
IP address		192	168	1	201
Sub net		255	255	255	0
Gateway		192	168	1	1
DNS		0	0	0	0
		Set		Cancel	

## Confirming the Operation

Confirm that the projector has connected to the LAN properly.

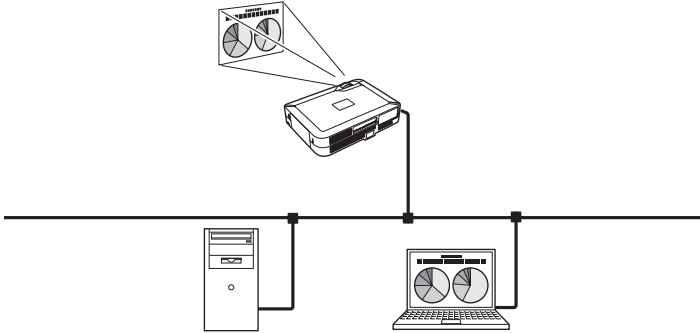

1. Activate "NetworkModule Client" or "NetworkModule Moderator" which is installed into the computer connected to the LAN .
2. After appearing "NetworkModule searching" message, the name of the projector\* appears on the Network Projector List, then the network setting has completed properly.

When the name of the projector does not appear and error screen appears, the network has not connected yet. Try searching again with the Refresh List button. If error screen appears again, reconfirm the LAN setting. When the projector is set where separated by the router, see next page.

When Firewall function (Anti-virus software) is effective, network projector may not be found. In that case, disable the Firewall function and try searching again.

\* If the projector is named, the name will be displayed. The name can be set with following the procedures in "6. Configurations with Browser" → "Quick Setup" (pp.44-45) or "Advanced Setup" → "Miscellaneous" (p.52). If the projector is not named, MAC address of the projector will be displayed.

NetworkModule Client screen

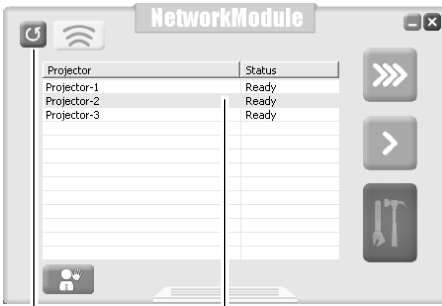

Refresh List button    Network Projector List

Error screen

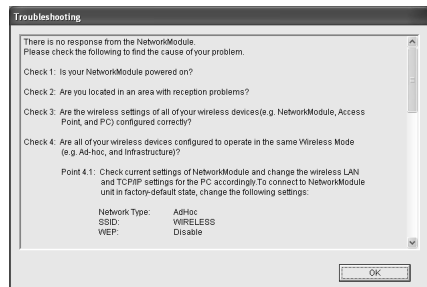

When set up the projector where separated by the router and the segment is different; Projector will not be found nor displayed. In this case, the projector needs to be searched directly by the IP address.

1. Click the Add NetworkModule button in the Advanced Settings menu. The Add NetworkModule screen will appear.
2. Click "Add" then the Enter IP address screen will appear. Enter the IP address and click "OK". The projector will be added on the Add NetworkModule screen. If you check "Check status", the connected projector will be checked periodically.
3. Click "OK" then the projector will be added on the Network Projector List.

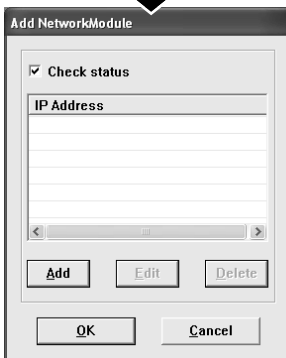
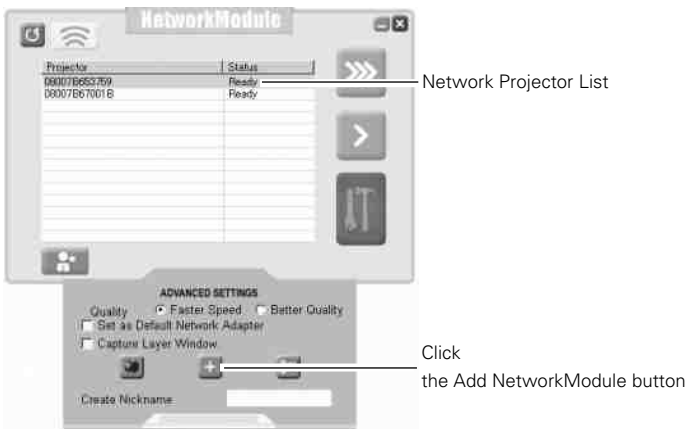

Add NetworkModule screen

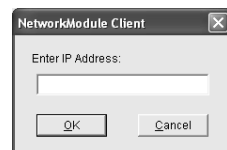
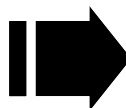

Enter IP Address screen

## User PIN Code

The User PIN code is to restrict the access from the networks to the projector. After setting the User PIN code, you need to enter it to operate the projector via the networks.

1. Select User PIN code, and press the SELECT button.  
The User PIN code screen will appear.
2. Set the User PIN code.

Set the figures with the Point ▲▼ buttons and move to the next items with the Point ◀▶ buttons. Select "Set" and press the SELECT button to set. To cancel the preset User PIN code, select "Cancel". When you do not want to set the User PIN code, set "0000".

It is recommended to set the User PIN code if you use the projector via the networks. You can also change the User PIN code. See "6. Configurations with Browser" → "Advanced Setup" → "User PIN code" (p.50).

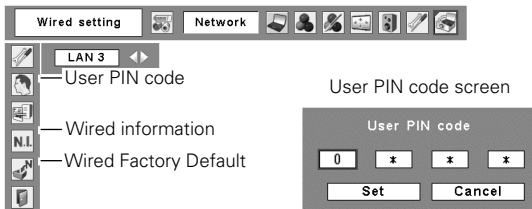

## Wired Information (See the menu above.)

Select Wired information from the projector menu and press the SELECT button to show LAN setting environment of the currently selected projector. (The description below is an example and different from what will be shown.)

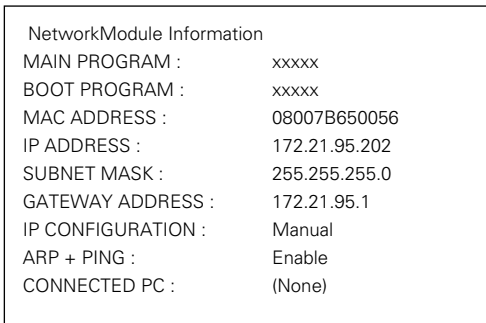

## Wired Factory Default (See the menu above.)

Return all the Wired LAN settings to the factory default settings which are shown on the next page.

## Factory Default Setting of the Wired LAN

Parameter	SELECTED LAN		
	LAN1	LAN2	LAN3
IP ADDRESS	169.254.100.100	192.168.100.100	192.168.100.100
SUBNET MASK	255.255.0.0	255.255.255.0	255.255.255.0
GATEWAY ADDRESS	255.255.255.255	255.255.255.255	255.255.255.255
DNS ADDRESS	255.255.255.255	255.255.255.255	255.255.255.255
IP CONFIGURATION	MANUAL	DHCP	MANUAL
INTERRUPT CONNECTION PERMISSION	ENABLE	ENABLE	ENABLE
IP CONFIGURATION with ARP+PING	ENABLE	ENABLE	ENABLE
DNS DOMAIN	-	-	-
SYSTEM PASSWORD	BLANK	BLANK	BLANK
USER PIN CODE	0000(NONE)	0000(NONE)	0000(NONE)

These settings can be made only by the browser.  
Refer to "6. Configurations with Browser" (pp.39–54).





## 5. Wireless LAN Configurations

---

This chapter describes the preparation for Wireless LAN setting with projectors and how to set the LAN environment.

To operate via Wireless LAN, attach the USB Wireless LAN Adapter to the projector.

The setting procedures and configurations differ depending on the LAN installation location. Consult your system administrator for installation and set the LAN appropriately.

To operate via Wireless LAN, your computer has to be equipped with a Wireless LAN card adapter which supports IEEE 802.11b/g.

If connecting in Infrastructure mode with an access point, the access point is required to support IEEE 802.11b/g.

Caution: Do not use a mobile phones or PHS near (within 20cm/8inch) the projector. It may cause malfunction.

# 5. Wireless LAN Configurations

## Attaching the USB Wireless LAN Adapter

Insert the USB Wireless LAN Adapter into the USB terminal of the projector. Inserting the adapter after verifying the shape of the connector in order not to break the terminal.

CAUTION: Use specified USB Wireless LAN Adapter. If you use other product, the projector will not be operated properly.

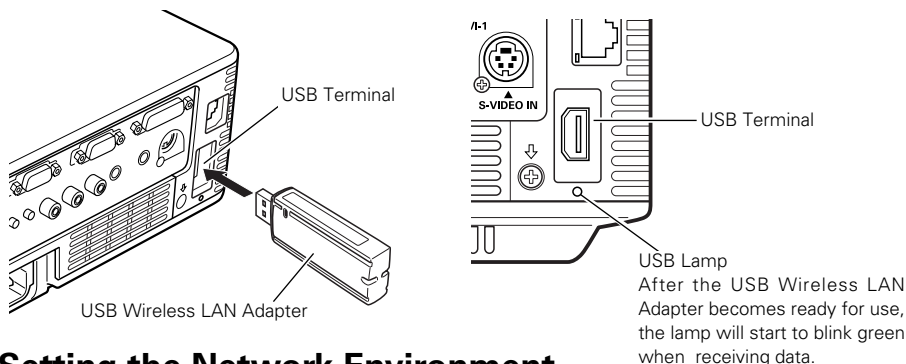

## Setting the Network Environment

Set the Wireless LAN network through the projector menu.

Detailed network settings will be made with browser. Refer to "6. Configurations with Browser". (p39–54) Complete the settings described in this chapter before performing the steps in "6 Configurations with Browser."

## Setting Procedures

With Easy setting, you can make Wireless LAN settings easily without any complicating settings (p.36).

1. Turn on the projector and select "Wireless" from the input menu of the projector. The Network connection standby display will appear and the "Please wait..." message will be displayed. Refer to "3. Names and Functions of the Operation Screen" → "Network Connection Standby Display" (p.20).

After short time, the message changes to " Ready for use". If the USB Wireless LAN Adapter is not attached to the projector, "Wireless" cannot be selected.

2. Select "Wireless Setting" from the projector menu and press the SELECT button. Select similar environment between LAN 4 and LAN 5 with the Point ◀▶ buttons. (LAN 4, LAN 5, and SIMPLE\* are factory default settings. Select similar environment to the installation location. For each settings, refer to the chart on page 38.)

\* "SIMPLE" mode is used for simple setting without complicated LAN setting procedures to connect to the Wireless LAN. See "Easy Setting" (pp.36–37) for details.

3. Press the Point button then the “Please wait...” message will appear and switching operation will start. Switching will take a while and after completing the operation the message will disappear. During the switching period, the projector cannot be operated.

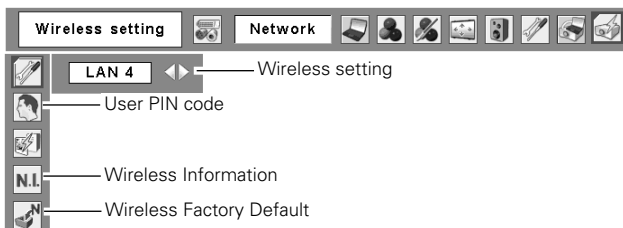

4. Press the SELECT button. LAN setting screen will appear and the selected LAN settings will be displayed. Adjust each item to the setting environment. Consult your system administrator for the detailed settings.

Adjust the figures with the Point ▲▼ buttons and move among the items with the Point ◀▶ buttons. When the network type is “AdHoc”, you do not have to change “Sub net” and “Gateway” and leave them as default settings.

SSID/ESSID/BSSID for the network type “Infrastructure” and “AdHoc” are required to be entered the same characters into the projector, the access point, and the Wireless LAN compatible computer (up to 32 characters). Characters can be selected from A~Z, a~z, blank (space), 0~9, or - (hyphen) with the Point ▲▼ buttons. Move to the next character with the Point ◀▶ buttons.

You can confirm that the projector settings from “Wireless Information” in the projector menu (p.37).

\* IP address can be set from the command of Windows. Refer to “11. Appendix” → “Setting up the IP address with “arp” + “ping” command” (p.96).

5. After completing all the settings, select “Set” and press the SELECT button. Now, all procedures has done. To cancel the adjusted settings, select the CANCEL button before clicking the SET button.

To confirm whether the settings are correct, follow the procedures in “4. Wired LAN configurations” → “Confirming the Operation” (pp.28–29).

For configuring of WEP security, select “Next”. Refer to “11. Appendix” → “Configuring WEP security with the projector” on page 97 for details.

LAN4		Wireless setting	
IP address	192 . 168 . 1 . 201		
Sub net	255 . 255 . 255 . 0		
Gateway	192 . 168 . 1 . 1		
DNS	0 . 0 . 0 . 0		
Network type	ADHOC		
SSID/ESSID/BSSID			
[Empty Input Box]			
<input type="button" value="Next"/> <input type="button" value="Set"/> <input type="button" value="Cancel"/>			

## Easy Setting

With this setting, you do not need any complex LAN setting procedures.  
The LAN mode will be AdHoc IEEE802.11b.

CAUTION: This function can be used only when logged in by Administrative right with Windows XP, and cannot be used with Windows 98SE/Me, Windows 2000. Windows XP should be Service Pack 1 or later version.

### Setting Procedures

1. Turn on the projector and select "Wireless" from the input menu of the projector.
2. Select "Wireless Setting" from the projector menu and press the SELECT button.
3. Select "SIMPLE" with the Point ◀▶ buttons. Press the Point button then the "Please wait..." message will appear and switching operation will start. Switching will take a while and after completing the operation the message "Ready for use" will appear. During the switching period, the projector cannot be operated. ("SIMPLE" LAN settings will be shown by pressing the SELECT button. The settings cannot be changed.)
4. Activate "NetworkModule Client" or " NetworkModule Moderator" which is installed in the computer.
5. Click the Easy setting button on the operation screen. The Wireless LAN setting screen will appear and the computer will start to set up the Wireless LAN setting. (Adjust the computer's Wireless LAN environment to the "SIMPLE" setting LAN environment.)

After completing the settings, the projector will start searching the projector which was set as "SIMPLE" and will display the name of the projector or the MAC address on the projector list.

Confirm whether the LAN has been set correctly and work properly. Refer to "4. Wired LAN configurations" → "Confirming the Operation" (pp.28–29) for the confirmation procedures.

If the network setup is not succeeded, the error screen will appear.

Setting screen

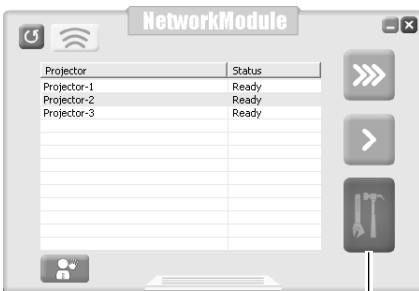

Easy setting button

Error screen

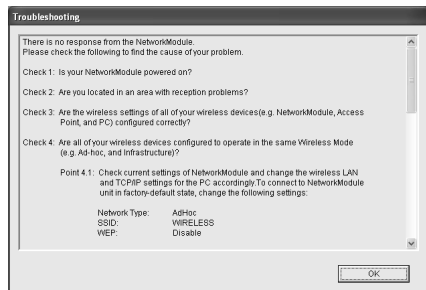

### Computer environment and Wireless LAN connection;

Wireless LAN with Easy setting connection will be made via AdHoc IEEE802.11b mode. For setting contents, refer to “Wireless LAN factory default settings” (p.38).

With the Easy setting, computer’s LAN environment setting will be switched to the settings on page 38. Because of that, the LAN cannot work for the other operation while using “NetworkModule Client” or “NetworkModule Moderator”.

After terminating the application, the LAN environment will automatically go back to the previous state.

## User PIN Code

The User PIN code is to restrict the access from the networks to the projector.

After setting the User PIN code, you need to enter it to operate the projector via the networks.

Select “User PIN code” from the projector menu. Set with the same procedures as setting Wired LAN User PIN code. Refer to “4. Wired LAN Configurations” → “User PIN code” (p.30).

## Wireless Information

Display the current LAN connecting environment. Select “Wireless Information” (p.35) and press the SELECT button.

Wireless Information (Example)

NetworkModule Information	
MAIN PROGRAM :	xxxxx
BOOT PROGRAM :	xxxxx
MAC ADDRESS :	08007B650056
IP ADDRESS :	169.254.53.0
SUBNET MASK :	255.255.0.0
GATEWAY ADDRESS :	255.255.255.255
IP CONFIGURATION :	DHCP
ARP + PING :	Enable
WIRELESS MODE :	802.11b
NETWORK TYPE :	AdHoc
CHANNEL :	11
SSID :	WIRELESS
WEP :	Disable
CONNECTED PC :	(None)

## Wireless Factory Default

Select “Wireless Factory Default” from the projector menu (p.35) and press the SELECT button. All the LAN settings will go back to the factory default settings. For details, refer to “Wireless LAN Factory Default Settings” (p.38).

## Wireless LAN Factory Default Settings

Factory default settings for LAN4, LAN5, and SIMPLE as follows.

Setting Items	Selected LAN		
	LAN4	LAN5	SIMPLE
IP ADDRESS	169.254.100.100	192.168.100.100	169.254. * . *
SUBNETMASK	255.255.0.0	255.255.255.0	255.255.0.0
GATEWAY ADDRESS	255.255.255.255	255.255.255.255	255.255.255.255
IP CONFIGURATION	MANUAL	DHCP	MANUAL
INTERRUPT CONNECTION PERMISSION	ENABLE	ENABLE	ENABLE
IP Address Setting with ARP+PING	ENABLE	ENABLE	DISABLE
WIRELESS CHANNEL	11	11	11
NETWORK TYPE	802.11b AdHoc	INFRASTRUCTURE	802.11b AdHoc
WIRELESS SSID/ESSID (SSID/IBSSID)	WIRELESS (NARROW CAPS)	ANY	WIRELESS (NARROW CAPS)
WEP (WEP encryption)	DISABLE	DISABLE	DISABLE
DNS DOMAIN	-	-	-
DNS ADDRESS	255.255.255.255	255.255.255.255	255.255.255.255
SYSTEM PASSWORD	BLANK	BLANK	BLANK
USER PIN CODE	0000(NONE)	0000(NONE)	0000(NONE)
LEAP USER PASSWORD	BLANK	BLANK	BLANK

These settings can be made only from "6. Configurations with Browser" (pp.39-54).

These items cannot be set.

## 6. Configurations with Browser

---

The projector can be set, controlled and operated via the browser.

Caution: When operating the projector with the browser, connect the projector to the computer with Wired or Wireless LAN. Complete the connection in advance.

The browser can set or operate:

- LAN setting  
Configure Wired/Wireless LAN environment.
- E-mail Setting  
Configure E-mail function to manage the projector remotely.
- Operation of Network Viewer  
Project and operate the image data on the network server. For details about the function, refer to "9. How to Use Network Viewer" (pp.63–71).
- Password Setting  
Configure the security password to control the projector.
- Others  
Other detailed settings.

# 6. Configurations with Browser

---

## Introduction

.....

To operate by the browser, you need to prepare and configure the environment. Check the environment of the browser and configure to operate the projector.

## Browser Environment

.....

Browser is required to support the following version.

Microsoft: Internet Explorer Ver.4.0 or later

Netscape Communications: Netscape Communicator Ver6.0 or later

## Browser Configuration

.....

Configure the operating environment of the browser. Configuration has to be accurate for proper operation.

### Using Proxy Server

#### Internet Explorer

Start up Internet Explorer. Select "Tools" → "Internet Options". Select the "Connections" tab and click the "LAN Settings" button in the "Local Area Network (LAN) Settings" field. Click the "Advanced" button in the "Proxy Server" field. Enter the IP address set on the projector in the "Do not use proxy server for addresses beginning with" field.

#### Netscape Navigator

Start up Netscape Navigator. Select "Edit" → "Setup" → "Category". Select "Details" and "Proxy", and check on "Set proxy manually." Click the "Display" button and enter the IP address of the projector in the "Proxy server is not used at address starting from the following IP address" field.

### Not using Proxy Server

#### Internet Explorer

Start up Internet Explorer. Select "Tools" → "Internet Options". Select the "Connection" tab and click the "LAN Setup" button in the "Local Area Network (LAN) Setup" field. Check off "Proxy server is used at local address" of the "Proxy Server" field.

#### Netscape Navigator

Start up Netscape Navigator. Select "Edit" → "Setup" → "Category". Select "Details" and "Proxy", and check "Connect Internet directly".



## Starting up the Browser

1. Turn on the projector.
2. Activate NetworkModule Client (or NetworkModule Moderator).
3. Select the projector to set from the Network Projector List. (Selected projector will be blue.)
4. Click the Advanced settings button to display the Advanced settings. Click the Configure NetworkModule button to display the NetworkModule Configuration screen.

You can also activate the screen directly from the browser screen without using NetworkModule Client (or NetworkModule Moderator). Enter the projector's Network IP address in the URL address bar of the browser.

Use this browser screen to configure various settings. The screen can be displayed either in "English" or "Japanese". Select "English".

Select the item to configure on the left side of the screen. Configure each item on the right side of the screen.

- \* While sending the data to the projector, you cannot activate the browser of the projector.
- \* The projector cannot be connected to via the networks while using the viewer.

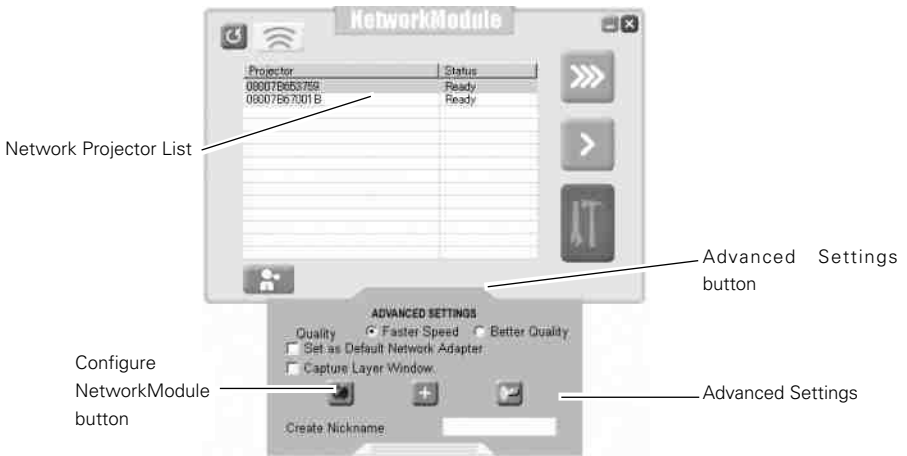

### Screen of Wired LAN



## Information

Display the current setting environment.

The contents differ depending on Wired or Wireless LAN environment.

### Screen of Wireless LAN

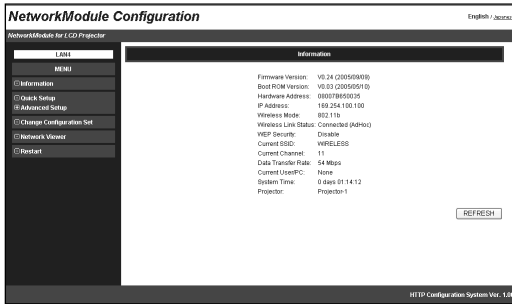

### Screen of Wired LAN

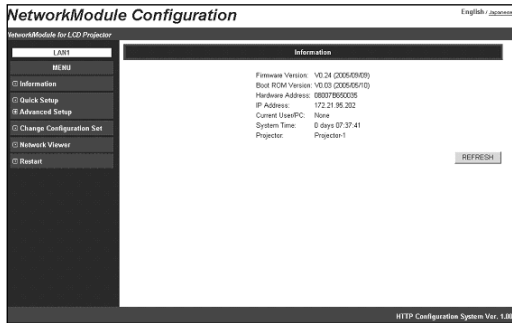

## Parameters and descriptions of Information

Parameter	Description
Firmware Version .....	Show the firmware version of the projector.
Boot ROM Version .....	Show the boot ROM version of the projector.
Hardware Address .....	Show the MAC address.
IP Address .....	Show the IP address currently set on the projector. If DHCP is set, the IP address assigned from the DHCP server is displayed.
Wireless Mode* .....	Show the Communication standard 802.11b or 802.11b.g
Wireless Link Status*.....	Show the Wireless communication mode and its status of the projector.
WEP Security* .....	Show the WEP (Encryption) setting status of the projector. However, the WEP key is not shown.
Current SSID* .....	Show SSID set on the projector.
Current Channel*.....	Show the channel, through which the projector is currently communicating.
Data Transfer Rate* .....	Show the current Wireless communication speed of the projector. The communication speed is automatically changed by the environment at that time (11/5.5/2/1/54/48/36/24/18/12/9/6 Mbps). The communication speed cannot be fixed.
Current User/PC.....	Show the IP address of the computer, which is currently transferring images to the projector
System Time .....	Show the elapsed time since the power is turned on. The time can be reset by selecting "Reset" from the browser configuration screen, or by disconnecting power from the projector and connecting back on.
Projector.....	Show the name of projector. (Can be changed.)
Refresh button .....	Refresh the displayed data.

\* Not shown at Wired LAN setting.

## Quick Setup

Set up minimum required items for operating the projector.

These settings can also be done in “Advanced Setup” (pp.46–52).

If you have set the items from the advanced setup, Quick Setup is not necessary.

Setting items differ depending on the Wireless LAN and Wired LAN.

To reflect the settings on the projector, click “APPLY”. For details about each item/button, see next page.

### When USB Wireless LAN Adapter is attached

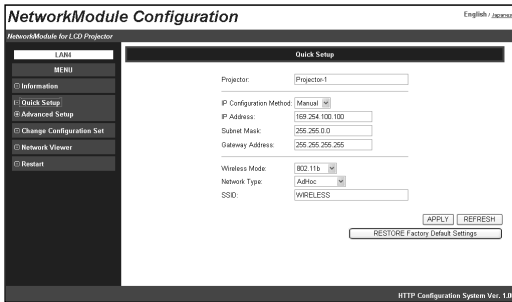

The screenshot shows the 'NetworkModule Configuration' interface for a projector. The 'Quick Setup' section is active. The 'Projector' field is set to 'Projector-1'. The 'IP Configuration Method' is set to 'Manual'. The IP address is '169.254.100.100', the subnet mask is '255.255.0.0', and the gateway address is '255.255.255.255'. The 'Wireless Mode' is set to '802.11b' and the 'Network Type' is 'AdHoc'. The 'SSID' field is empty. There are 'APPLY' and 'REFRESH' buttons, and a 'RESTORE Factory Default Settings' button. The bottom right corner indicates 'HTTP Configuration System Ver. 1.10'.

### When Wired LAN is connected

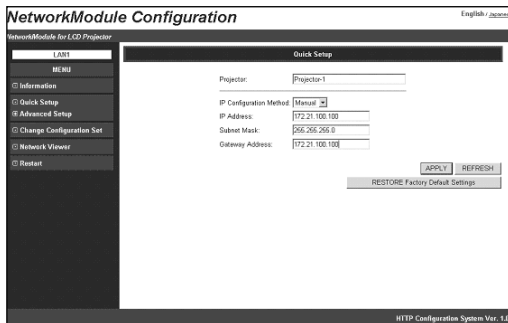

The screenshot shows the 'NetworkModule Configuration' interface for a projector. The 'Quick Setup' section is active. The 'Projector' field is set to 'Projector-1'. The 'IP Configuration Method' is set to 'Manual'. The IP address is '172.21.100.100', the subnet mask is '255.255.255.0', and the gateway address is '172.21.100.100'. There are 'APPLY' and 'REFRESH' buttons, and a 'RESTORE Factory Default Settings' button. The bottom right corner indicates 'HTTP Configuration System Ver. 1.10'.

Parameter	Description
Projector .....	Name each projector to distinguish it from other projectors (up to 32 one-byte characters). The name set here will be displayed on the Network Projector List in the application operation screen.
IP Configured Method .....	A desired IP address setup method is selected from "Manual", "DHCP", and "BOOTP". If "DHCP" or "BOOTP" is selected, the IP address is obtained automatically as "DHCP client" or "BOOTP client". At this time, it is necessary that the DHCP server/BOOTP server must be in the environment allowing the network communication. IP Address, Subnet Mask, and Gateway Address fields will be displayed "-.-.-", when the IP Address Configuration Method is set to DHCP or BOOTP and failed to get the figures from the DHCP server, the computer cannot be connected to the projector. If the projector fails to obtain IP address from BOOTP server, the existing IP address will be assigned.
IP Address .....	Set the IP address in the environment you wish to use. If "IP Configuration Method" is set to "DHCP" or "BOOTP", this setting is not needed.
Subnet Mask .....	Set the Subnet mask in the environment you wish to use. If "IP Configuration Method" is set to "DHCP" or "BOOTP", this setting may become unnecessary depending on the settings of "DHCP Server" and "BOOTP Server".
Gateway Address .....	Set the gateway address in the environment you wish to use. If "IP Configuration Method" is set at "DHCP" or "BOOTP", this setting may become unnecessary depending on the settings of "DHCP Server" and "BOOTP Server". If any segment beyond the router is not used, the gateway address can be remained "255.255.255.255".
Wireless Mode* .....	Select the Communication mode 802.11b or 802.11g.
Network Type* .....	Select either "Infrastructure" or "AdHoc".
SSID* .....	Set the SSID/ESSID (up to ASCII 32 characters). SSID/ESSID is case-sensitive. Even though all characters projected in Wired/Wireless information are uppercase, it is necessary to distinguish between upper case and lower case characters.
APPLY button .....	Click the APPLY button to update. The screen to restart the projector will be displayed.
REFRESH button .....	Update and show the adjusted data.
RESTORE Factory Default Settings button .....	Restore the settings to the values at the factory.

\* Not displayed at Wired LAN setting.

# Advanced Setup

(Click “+” mark to display the subitems.)

## TCP / IP

TCI/IP related items can be configured on this screen.

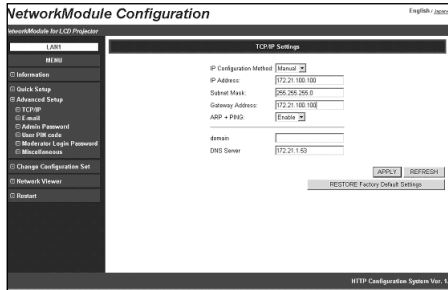

Parameter	Description
IP Configuration Method .....	A desired IP address setup method is selected from “Manual”, “DHCP”, and “BOOTP”. If “DHCP” or “BOOTP” is selected, the IP address is obtained automatically as “DHCP client” or “BOOTP client”. At this time, it is necessary that the DHCP server/BOOTP server must be in the environment allowing the network communication. IP Address, Subnet Mask, and Gateway Address fields will be displayed “-.-.-”, when the IP Address Configuration Method is set to DHCP or BOOTP and failed to get the figures from the DHCP server, the computer cannot be connected to the projector. If the projector fails to obtain IP address from BOOTP server, the existing IP address will be assigned.
IP Address .....	Set the IP address in the environment you wish to use. If “IP configuration Method” is set to “DHCP” or “BOOTP”, this setting is not needed.
Subnet Mask .....	Set the Subnet mask in the environment you wish to use. If “IP Configuration Method” is set to “DHCP” or “BOOTP”, this setting may become unnecessary depending on the settings of “DHCP Server” and “BOOTP Server”.
Gateway Address .....	Set the gateway address in the environment you wish to use. If “IP Configuration Method” is set to “DHCP” or “BOOTP”, this setting may become unnecessary depending on the settings of “DHCP Server” and “BOOTP Server”. If any segment beyond the router is not used, the gateway address can be remained “255.255.255.255”.
ARP+PING .....	Select “Enable” or “Disable” the IP address setup using “arp” and “ping” (Refer to page 96 for details.)
Domain .....	Enter the domain name where the projector belongs to (up to ASCII 254 characters).
DNS Server .....	Enter the address of the DNS server.
APPLY button .....	Click the APPLY button to update. The screen to restart the projector will be displayed.
REFRESH button .....	Update and show the adjusted data.
RESTORE Factory Default Settings button .....	Restore the settings to the values at the factory.

## Wireless Setting

Wireless related items can be configured on this screen.

This screen will not be displayed at Wired LAN setting.

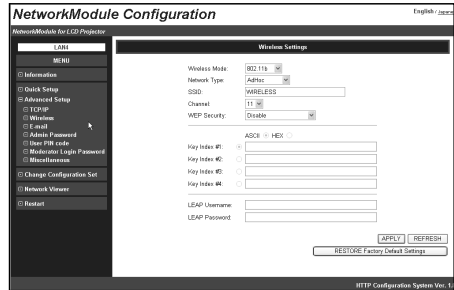

Parameter	Description
Wireless Mode .....	Select the Communication standard 802.11b or 802.11b.g
Network Type .....	Select either "Infrastructure" or "AdHoc".
SSID* .....	Set the SSID/ESSID. (up to ASCII 32 characters) SSID/ESSID is case-sensitive. Even though all characters on the Wireless information is uppercase, it is necessary to distinguish between upper case and lower case characters.
Channel.....	If you use the projector in 802.11AdHoc mode, select the channel, from 1 to 11.
WEP Security .....	Select "Enable" or "Disable" the WEP (Encryption). When using WEP, select any of following items corresponding to this WEP; "Enable 40-bit", "Enable 104-bit", "Enable 128-bit", and "Enable (802.1x"LEAP")." When enabling WEP (Encryption), the image transfer speed may become slower.
WEP Key#1–Key#4.....	Set WEP key in the hexadecimal notation (0 to F). 5 bytes are set for 40-bit WEP, 13 bytes are set for 104-bit, and 16 bytes are set for 128-bit WEP. Four WEP keys can be set, however, the only one with check on its radio button is in effect. Both of the number and value of the WEP key in effect must be same as those of your computer and the access point. Depending on computers and access points, you may be allowed to select only one WEP key. In this case, use WEP key 1.
LEAP Username/Password .....	When selecting 802.1 x "LEAP" in WEP security, enter the user name and the password. Enter with ASCII 64-byte capital characters and one-byte characters. Consult your system administrator about the user name and the password.
APPLY button .....	Click the APPLY button to update. The screen to restart the projector will be displayed.
REFRESH button .....	Update and show the adjusted data.
RESTORE Factory Default Settings button .....	Restore the settings to the values at the factory.

E-mail

The projector has a function to send e-mails to inform its operating condition to the administrators or users. This function can not be used for Wireless AdHoc mode. This function is available only for Wired or Wireless LAN infrastructure mode.



Parameter	Description
SMTP Server .....	Enter the address of SMTP server (up to ASCII254 characters).
Administrator Address .....	Enter the E-mail address of administrator (up to ASCII254 characters).
Mail Address .....	Enter E-mail addresses of users (up to ASCII254 characters).
Option.....	.When the checked item has occurred, the projector sends alert messages.
Time .....	Set the time of "Accumulated Lamp-use time reaches in ***hours".
Attached Message.....	Attach the message to the e-mail of "Accumulated Lamp-use time reaches in ***hours" (up to ASCII220 characters).
APPLY button.....	Click the APPLY button to update. The screen to restart the projector will be displayed.
REFRESH button .....	Update and show the adjusted data.
RESTORE Factory Default Settings button .....	Restore the settings to the values at the factory.



## Admin Password

Set the Admin Password to prevent unauthorized person from changing the settings of the projector. At the factory settings, the Admin Password is not set.

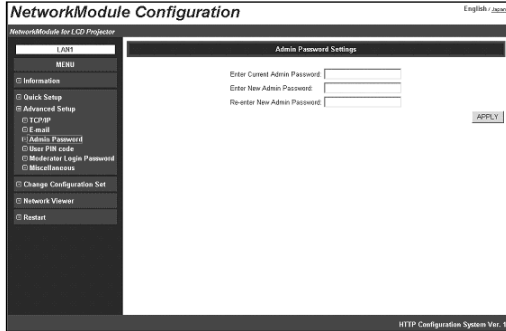

Parameter	Description
Enter Current Admin Password.....	Enter the currently set admin password. The password you have entered is displayed as "●●●●●●●●" (up to ASCII32 characters).
Enter New Admin Password .....	Enter a new admin password you wish to set. The password you have entered is displayed as "●●●●●●●●" (up to ASCII32 characters).
Re-enter New Admin Password.....	Re-enter the new admin password you wish to set. The password you have entered is displayed as "●●●●●●●●" (up to ASCII32 characters).
APPLY button .....	Click the APPLY button to update. The screen to restart the projector will be displayed.

If you set the admin password for the first time, do not enter any password in the "Enter Current Admin Password" field. Enter a password in "Enter New Admin Password" and "Re-enter New Admin Password" fields.

When you change the settings next time, the password will be required to enter. Leave the "User name" field blank and enter the password you set.

\* The password set here is also used as PJ link password.



### User PIN code

With this screen, you can set the User PIN code to transfer the image to the projector and to activate PJ Controller.

You can set different PIN code as you set for Admin Password (p.49).

When you reset the User PIN code, you do not need to enter the current PIN code.

At the factory setting, the User PIN code is not set.

If you do not need to set a PIN code, enter "0000".

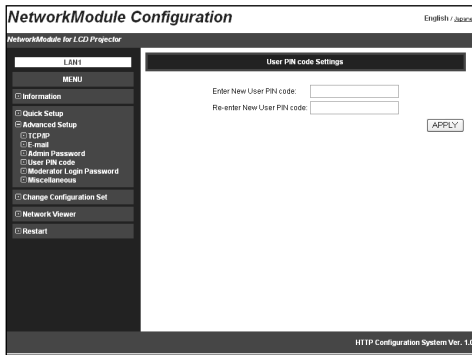

Parameter	Description
Enter New User PIN code .....	Enter a new PIN code you wish to set. The PIN code you have entered is displayed as "●●●●" (four-digit numbers).
Re-enter New User PIN code.....	Re-enter the new PIN code you wish to set. The PIN code you have entered is displayed as "●●●●" (four-digit numbers).
APPLY button.....	Click the APPLY button to update. The screen to restart the projector will be displayed.

## Moderator Login Password

To use the Moderator function, you need to set the Moderator Login password here. For operating the Moderator function, a Moderator Login password is required on this screen. When resetting the Moderator Login password, you do not need to enter the current Moderator Login password. Default setting is blank. If you do not want to set a password, leave here blank.

\* First, you need to set the admin password (p.49) or you cannot set the moderator login password.

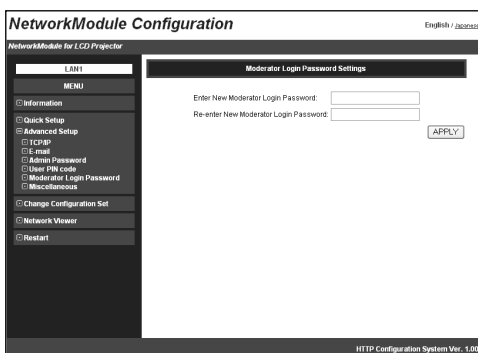

Parameter	Description
Enter new Moderator Login password.....	Enter new Moderator Login password. After inputting, the figure will be displayed as “●●●●”. The password consists of four -digit number.
Re-enter new Moderator Login password ...	Reenter new Moderator Login password. After inputting, the figure will be displayed as “●●●●”.
APPLY button .....	Click the APPLY button to update. The confirmation message about updating the Moderator Login password will be displayed.

Miscellaneous

You can set the name to the projector. The set name will be displayed on the Network Projector List of the application operating screen.

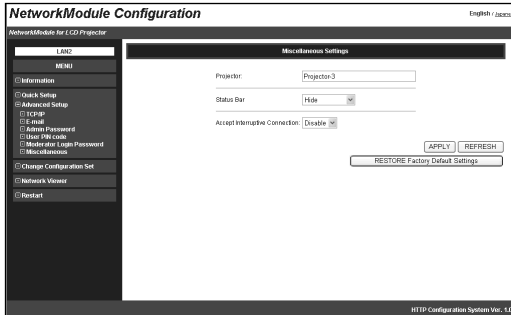

Parameter	Description
Projector .....	Name a projector to distinguish it from other projectors (up to 32 characters). The name set here will be displayed on the Network Projector List.
Status Bar .....	Select "Expand view" or "Hide" the Status bar on the network connection standby screen. When selecting "Hide", the Status bar on the network standby screen will be disappeared. Refer to "3. Names and Functions of the Operation Screen" → "Network Connection Standby Display" (p.20).
Accept Interruptive Connection .....	Enable or Disable the interruptive connection to the projector which is connected to other computer when you send images using projector. (See "7. Project the Image via the networks" (p.56) for further detail.)
APPLY button.....	Click the APPLY button to update. The screen to restart the projector will be displayed.
REFRESH button .....	Cancel the new settings.
RESTORE Factory Default Settings button .....	Restore the settings to the values at the factory.

## Change Configuration Set

Select a LAN settings from LAN1–LAN3, Off, LAN4, LAN5, and SIMPLE. With this screen, you can also confirm some settings (Projector name, IP Configuration Method, IP Address, Wireless Mode, Network Type, Channel, SSID, WEP Security). Depending on Wireless or Wired input, setting items will be varied.

### Wireless LAN set menu

The screenshot shows the 'Change Configuration Set' screen for a Wireless LAN configuration. The interface includes a left-hand menu with options like Information, Quick Setup, Data Setup, Advanced Setup, LAN, TCP/IP, Email, Admin Password, User PIN code, Administrator Login Password, and Miscellaneous. The main area displays the following settings:

Change Configuration Set			
	<input checked="" type="radio"/> LAN4	<input type="radio"/> LAN5	<input type="radio"/> Simple
Projector	Projector-1		
IP Configuration Method	Manual	DHCP	Manual
IP Address	192.248.100.100	172.21.95.209	169.254.53.0
Wireless Mode	802.11b	802.11b	802.11b
Network Type	AdHoc	Infrastructure	AdHoc
Channel	11	11	11
SSID	WIRELESS	ANY	WIRELESS
WEP Security	Disable	Disable	Disable

Buttons for 'APPLY' and 'REFRESH' are located at the bottom right of the configuration area. The footer indicates 'HTTP Configuration System Ver. 1.0'.

### Wired LAN set menu

The screenshot shows the 'Change Configuration Set' screen for a Wired LAN configuration. The interface is similar to the wireless version but with different options. The main area displays the following settings:

Change Configuration Set			
	<input checked="" type="radio"/> LAN1	<input type="radio"/> LAN2	<input type="radio"/> LAN3
Projector	Projector-1	Projector-1	
IP Configuration Method	Manual	DHCP	Manual
IP Address	172.21.95.202	172.21.95.202	192.168.100.100

Buttons for 'APPLY' and 'REFRESH' are located at the bottom right of the configuration area. The footer indicates 'HTTP Configuration System Ver. 1.0'.

Parameter	Description
LAN1–5,.SIMPLE*	Select a LAN setting from LAN1–3, LAN4, LAN5, and SIMPLE.
APPLY button	Click the APPLY button to update. The screen to restart the projector will be displayed.
REFRESH button	Cancel the new settings.

\* LAN4, LAN 5, and SIMPLE will be displayed when USB Wireless LAN Adapter is inserted.

# Restart

You can restart the projector on this screen.

To enable the new settings, the projector has to be restarted. Click "RESTART".

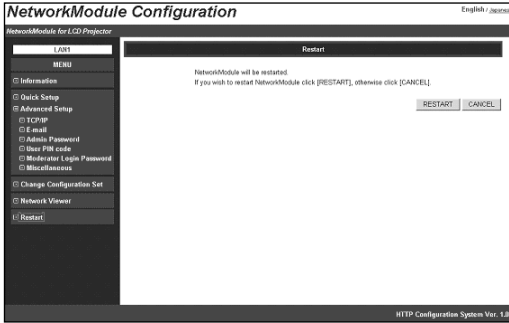

Parameter	Description
RESTART button .....	Click this button when you restart the projector after completing the settings.
CANCEL button .....	Cancel to restart the projector.

## **7. Project the Image via the Networks**

---

Project the image on the computer screen by operating the projector which is connected to the networks.

# 7. Project the Image via the Networks

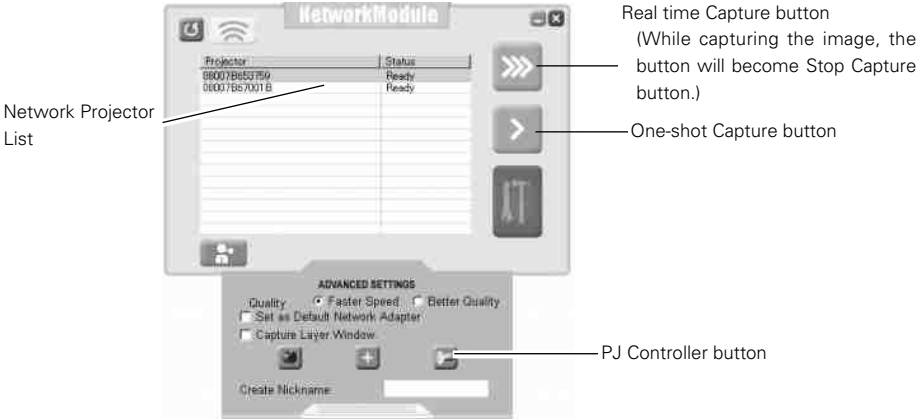

1. Activate NetworkModule Client (Participants) or NetworkModule Moderator (Moderator).
2. Adjust the projector input to the selected network (Wired or Wireless) with the PJ Controller. When operating multiple projectors, adjust each projector independently. Refer to “10. How to Use the PJ Controller” (pp.73–90).
3. Select a projector from the Network Projector List with a mouse cursor. When selecting multiple projectors at the same time, press the [Ctrl] key and select projectors with the mouse cursor. Selected projector will be blue. You can operate up to 5 projectors at the same time.
4. Click the Real time Capture button to project the computer image in real time.
  - \* If the projector has already been being used, “In-use” message will appear on the Network Projector List. When the “Accept Interruptive Connection” setting is “Enable”, you can use the projector even if it has “In-use” message. When the setting is “Disable”, you cannot use the projector. Refer to “6. Configurations with Browser” → “Advanced Setup” → “Miscellaneous” (p.52).

On the Real time Capture screen, the destination projector will be displayed in blue or black. When Real time capturing has been done, the Real time Capture button will become the Stop Capture button.

Click the One-shot Capture button to project a copied still picture of the computer screen. The quality or transmission speed of the projected picture can be set through Advanced settings. Click the Advanced settings button to display the menu. Select “Quick” or “Clear” with the check button.

When selecting “Quick”, the image transmission speed will be quicker but the image quality will be lower. When selecting “Clear”, the image quality will be better but the transmission speed will be slower.

When the User PIN code has been set, User PIN code screen will appear after clicking the Capture buttons. If multiple projectors have different PIN codes, you need to enter PIN codes for every projector. To set the User PIN code, refer to “4. Wired LAN setting” → “Set the User PIN code” (p.30), “6. Configurations with Browser” → “Advanced Setup” → “User PIN code” (p.50). The same procedure will be required when operating via Moderator screen (NetworkModule Moderator). While projecting the image in real time, the projector cannot be operated via PJ Controller or browser.

\* The projector cannot be connected to via the networks while using the viewer.



## **8. Use the Moderator Function**

---

With Moderator function, the moderator can project the participants' computer screen through the projector in meetings or in classes.

# 8. Use the Moderator Function

## Moderator Function

This function is useful for a moderator or a teacher to conduct a meeting or a class, where all the participants including the moderator (teacher) are assigned a computer, to project images from each participant's computer. A moderator (teacher) has the right to decide which computer image to project. One moderator (teacher) can conduct up to 50 computers.

This function enables you to project the participants' data directly in a short time and in real time without taking time to transfer the data to the computer connected to the projector.

The image data will not be limited by the computer's application because the data transfer of each computer adopts the screen capturing system.

Names and terms used in this chapter have following meanings.

- Moderator .....Moderator or teacher
- Client.....Participant of meetings or the classes
- NetworkModule Moderator .....The application which the moderator uses
- NetworkModule Client.....The application which the participants use
- NetworkModule .....The projector which is connected to the networks

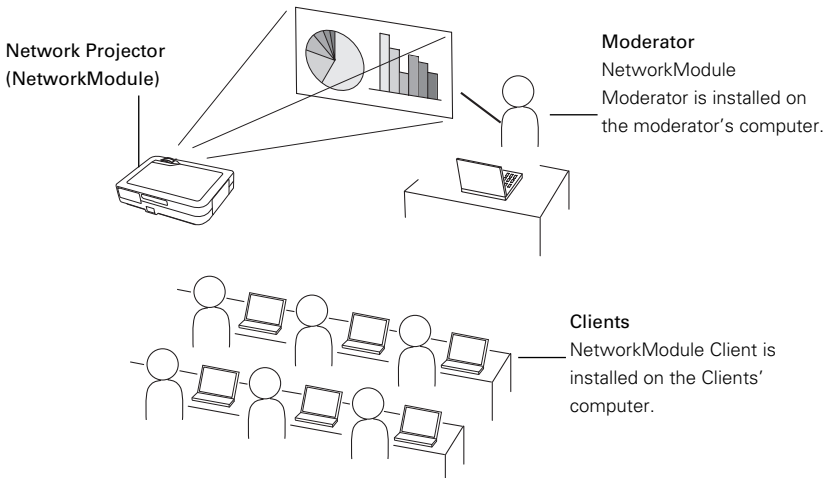

## Preparation for Using the Moderator Function

First, follow the procedure in “2. Setup Procedure” → “Step 1–3” (p.16) and confirm that the setting status is set as written below.

- Client application (NetworkModule Client) is installed on each client’s (except for the moderator) computer and each client’s computer image can be projected.
- Moderator application (NetworkModule Moderator) is installed on the moderator’s computer and moderator’s computer image can be projected.

## Preparation Procedure for Using the Moderator Function

1. Configure the Moderator Login password in the projector to put the projector under moderator’s control (p.51).
2. Register a moderator in the projector with the moderator screen. Set the Session password at this step. After the registration, only the moderator can control the projector and clients cannot operate.
3. Each client registers to join the moderator’s group.

Now, Moderator function is set. The moderator and the clients can start the meeting with Moderator function.

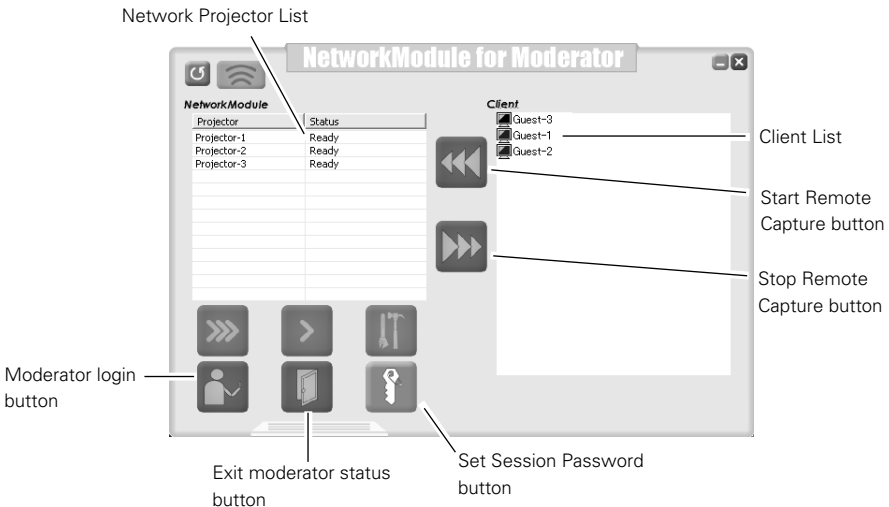

## Setting the Moderator Function

.....

\* See page 62 for Easy Settings.

1. Turn on the Moderator's computer and activate the moderator's application.  
Turn on the each client's computer and activate each of the applications.

### Registration of the Moderator

2. The moderator sets the Moderator Login password to the projector. When operating multiple projectors, set passwords to all the projectors. It is preferable to set the same password to all the projectors.  
Configure the setting with the browser. Refer to "6. Configurations with Browser" → "Advanced Setup" → "Moderator Login Password" (p.51).
3. Register the moderator to each projector through the moderator screen. Select the projector on the screen (The selected projector will be blue.) and click the Moderator login button.
4. "Set Session Password" screen will appear.  
Enter the same password (less than 17 one-byte characters) into the two input boxes and click "OK".



5. Moderator login password confirmation screen will appear.  
Enter the password set in step 2 and click "OK". The projector has been put under the moderator's control. The projector will be pink in the Network Projector List.  
Repeat step 3, 4, 5 and put each projector under the moderator's control. After completing the setting, the registered projector can only connect to the computers which belong to the session group.



## Registration of the Clients (Participants)

6. Select the projector (Selected projector will be blue.) in the group from the client screen. (Moderator's projector will be pink.) Click the Join the moderated session button.

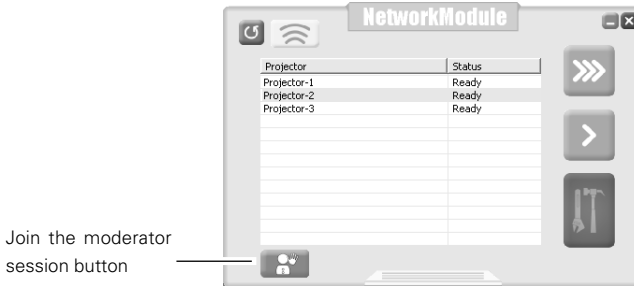

7. Set session password screen will appear. Enter the password registered by a moderator (Being registered at step 4)



8. Click "OK". The client screen will disappear and the projector icon will be displayed in the task tray of the computer. After the step, the client's (participant's) computer name will be put under the moderator's control. When joining the session, the client's computer (or the nickname) will be displayed in the moderator's client list screen.

To quit the session, right-click the projector icon on the computer task bar and select "Exit from the moderated session" from the menu. The client screen will appear and the client has left the group.

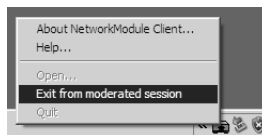

- \* Set session password screen will be displayed by clicking the Set session password button. Enter new password, then it will be a new password. If the password has changed while the session is in progress, the clients who are participating the session will not be excluded from the session.
- \* The projector displayed in red on the client's screen means it is for moderator. Operation cannot be done through the client screen.

All the preparation settings have been done for moderator function. Follow the instructions of "How to Use Moderator Function" on the next page for the operation.

## Unregister from Moderator Status

1. Select a projector which is registered as a moderator from the moderator screen.
2. Click the Exit moderator status button. Selected projector will be unregistered as a moderator.  
When there are multiple projectors to unregister, repeat the procedure for each projector.  
The moderator cannot unregister while an image is transferring to the projector. First, stop transferring the image and then unregister.  
After unregistering, client's name will be disappear from the client list on the moderator screen.
  - \* Even after the moderator is unregistered, the function will not finish automatically in the clients computers. Each client needs operation to quit the session.
  - \* After terminating the moderator's application, all the clients joined in the session will be unregistered.

## How to Use the Moderator Function

The moderator function is to project each client's (participant's) images on the computer with the moderator's operation. Clients themselves cannot operate to project the image directly.

### Project the Client's Images

1. Select the client to display its computer image from the client list with the computer mouse. (Selected client will be blue.)
2. Select the projector to project the image with the computer mouse. (Selected projector will be blue.) When projecting through multiple projectors, select the projectors with the computer mouse by holding the [Ctrl] key.
3. Click the Capture button. Selected client's image will be projected from the projector in real time.

### Stop Projecting the Client's Images

Select the client to stop being projected the image from the client list, and click the Stop Remote Capture button. The capturing will stop.

- \* The client whose image is projecting cannot exit from the session. Once its image stops being projected, the client can exit.
- \* If the moderator's image is projected by the One-shot Capture button or the Real time Capture button, the client's image which is being projected will be cancelled.

## Easy Settings for Moderator Function (Set the Moderator Login password)

You do not have to set each Moderator Login password for every equipment if following the instructions. The password is to control the projector and clients' computers thoroughly. By following procedures, you can omit inputting the password to use the moderator function more simply.

1. Skip step 2 of "Set the Moderator Function" (p.60). Do not set the password.
2. Enter the Session password in step 4.  
When the other group is not using the function, you can also skip the password. Click "OK" without inputting each box (without password). When the other group is using the function, enter the password here to prevent the session from interfering.
3. The confirmation screen in step 5 will not appear.
4. Each client (participants) will joins the session in step 6. Inputting the password will not be required.  
When setting the Moderator Login password in step 2, you need to enter the password here.

## 9. How to Use Network Viewer

---

Project images on a FTP server, which is on the same LAN with the projector, through the projector by operating a projector or a computer.

First, check if the projector and the computer are connected to the networks correctly with Wired or Wireless, to project the image properly.

# 9. How to Use Network Viewer

## The Mechanism of Network Viewer and the Flow of the Signal

Network Viewer is to project an image stored on a FTP server which is on the same LAN as a computer, through the projector by operating a computer or a projector. The flow of the signal for each communication mode is shown below.

### ■ Wireless LAN Infrastructure Communication Mode

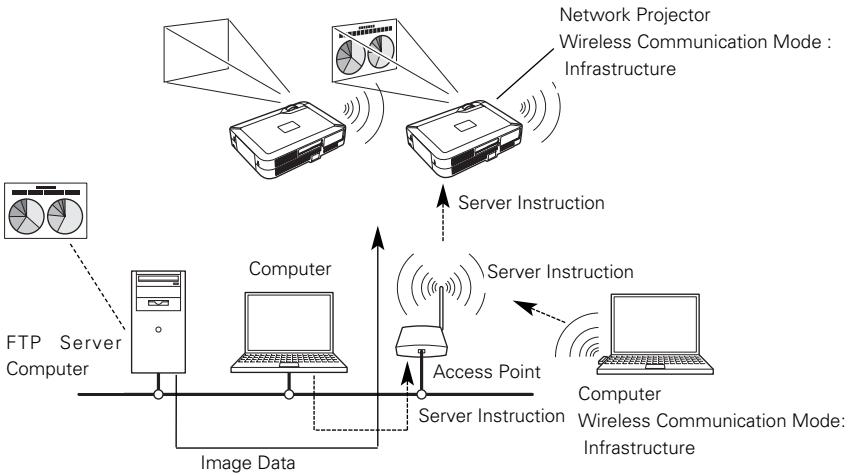

### ■ Wireless LAN AdHoc Communication Mode

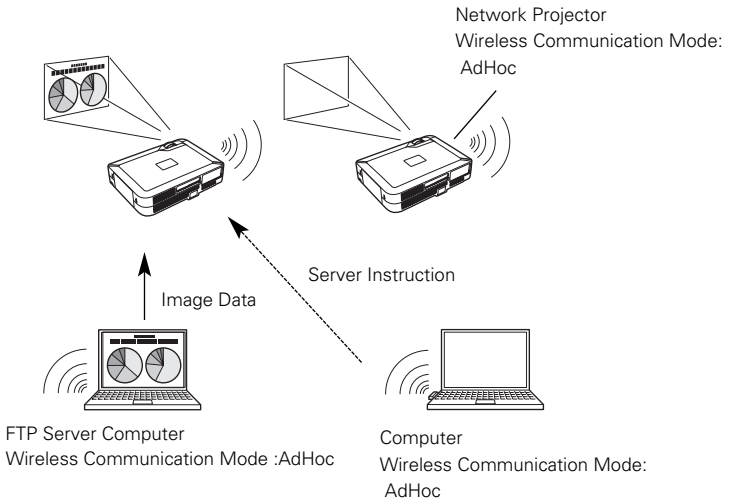



## ■ Wired LAN Communication Mode

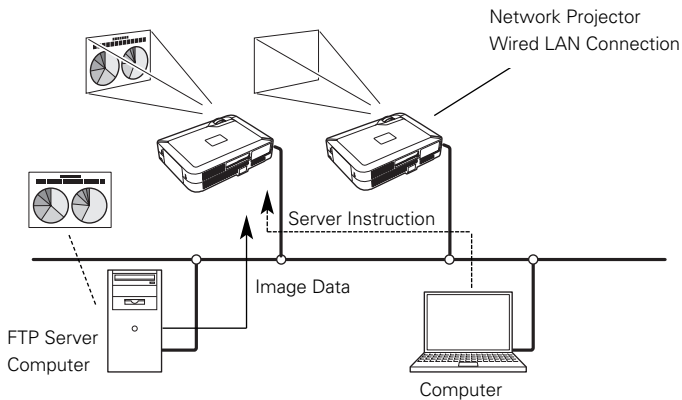

## Operation

Procedures for projecting the images on the FTP server are as follows.

1. Information about the FTP server, which provides images, is sent from the computer to the projector and the information will be held.
2. The computer issues an instruction to project the image, then the projector will follow the instruction and read the image data each time to project.  
The projector can also instruct to project images on FTP server. In this case, operation written in step 1 is required in advance.

## Functional Conditions of FTP Server Which Provides Images

- \* FTP Service can be available with Windows NT4.0, Windows2000 Professional, or Windows XP Professional.
- \* FTP Server has an account which has full account right or allows an anonymous account.

## Projecting the Image

Operation can be made with any of 1) PJ Controller, 2) Browser, or 3) Projector.

When operating with the projector, first, set the FTP server which provides images with 1) PJ Controller or 2) Browser.

Operate as follows.

### 1) Operating with the PJ Controller

1. Select the projector input (Wired/Wireless).

Select "Wireless" for Wireless LAN and "Wired" for Wired LAN for the input source of the projector. Activate "NetworkModule Client" or "NetworkModule Moderator".

Detected projector names and IP addresses will be displayed.

2. Specify the projector to display the image.

Only one projector can be selected.

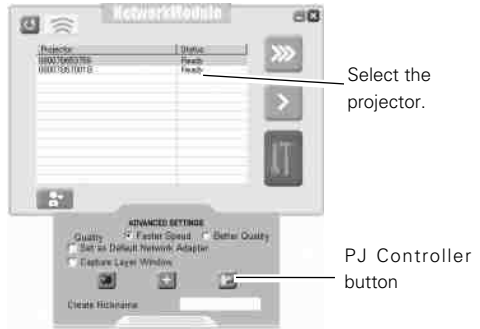

3. Click the PJ Controller button to display the PJ Controller screen. First, make "Initial Setting" from the main menu. Refer to "10. How to Use the PJ Controller" → "Initial Settings" (p.75).

4. Select Network Viewer from the Main Menu. Operation window (next page) will be displayed.

### [Network Viewer]



5. Specify the FTP server to provide image data
  - Host Name.... Enter IP address of the server.
  - Folder Path.... Specify the directory where image data are stored. When the image data is in the root directory, just "/" will be displayed. When the image data is in a specified directory, put slashes "/" between directories such as /test/data etc.
  - User ID .....Enter login ID access to the server.\*
  - Password .....Enter login password access to the server.\*
    - \*If both the User ID and password are anonymous, enter "anonymous".
  
6. Click Set button
  - Click Set button to set up the server information on the specified projector.
  - The configured server information can be stored even if you unplug the projector .
  
7. Select Play Mode and display the image
  - Play Mode .....Auto (Infinite Loop) (Keeps playing images repeatedly)
    - Auto (Plays or pauses all the images according to the Auto Play Setting mode)
    - Manual (Plays images manually)
  - Auto Play Settings..Sec. (Sets time of playing back a image.)
    - Times (Select number of times of play back images.)
  - Start.....Start playing back images.
  - Stop .....Stop playing back images.
  - Pause .....Suspend playing back images in Auto Play mode.
  - Return .....Return to the previous page manually in Manual mode
  - Next .....Go to next page manually in Manual mode.

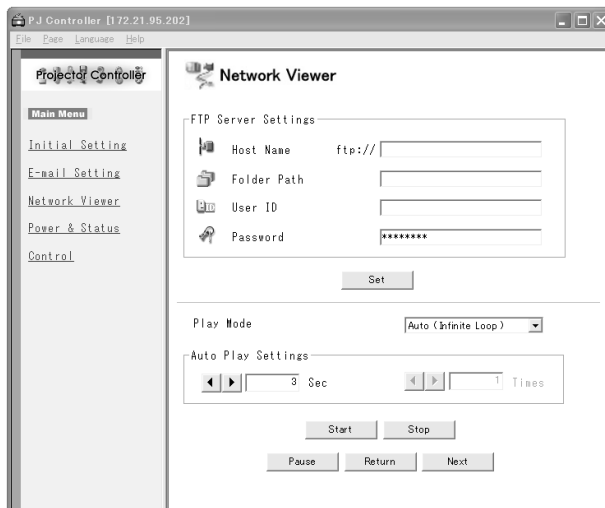

## 2) Operating with the Browser

1. Select “Wireless” for Wireless LAN and “Wired” for Wired LAN from the input menu of the projector.  
Activate “NetworkModule Client” or “NetworkModule Moderator”.  
Operating directly from the browser is also possible. In this case, enter the projector IP address directly into browser’s address bar.

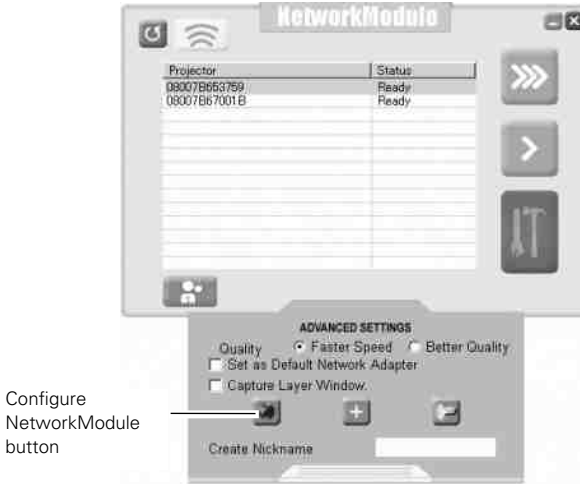

2. Specify the projector to display the image  
Only one projector can be selected.
3. Click “NetworkModule Setting” button (see page 39).  
The browser will start and projector setting screen will appear.  
Select Network Viewer from the MENU.  
Network viewer operation (next page) will appear.

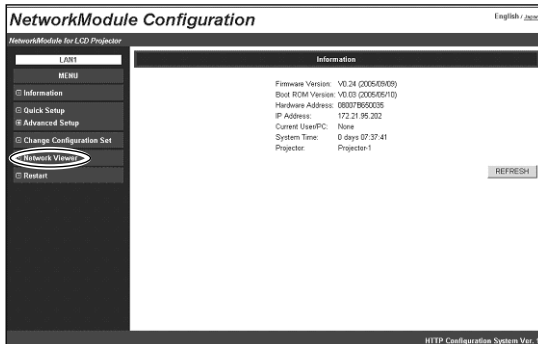

4. Specify the FTP server to provide image data
  - Host Name.....Enter the IP address of the server.
  - Folder Path.....Specify the directory where image data are stored. When the image data is in the root directory, just "/" is displayed. When the image data is in a specified directory, put slashes"/" between directories such as /test/data etc.
  - User ID .....Enter the login ID access to the server.\*
  - Password .....Enter the login password access to the server.\*

\*If both the User ID and password are anonymous, enter "anonymous".
  
5. Click APPLY button
  - Click APPLY button to set up the server information on the specified projector.
  - The configured server information can be stored even if you unplug the projector .
  
6. Select Play Mode and display the image
  - Play Mode .....Auto (Infinite Loop) (Keeps playing images repeatedly)
    - Auto (Plays or pauses all the images according to the Auto Play Setting mode)
    - Manual (Plays images manually)
  - Auto Play Setting...Sec. (Sets time of playing back a image.)
    - Times (Select number of times of play back images.)
  - Start.....Start playing back images.
  - Stop .....Stop playing back images.
  - Pause .....Suspend playing back images in Auto Play mode.
  - Return .....Return to the previous page manually in Manual mode.
  - Next .....Go to next page manually in Manual mode.
  - REFRESH .....Update and show the adjusted data.
  - RESTORE Factory Default Settings
    - .....Restore the factory default settings of Network Viewer.
    - (All the values will return to the factory default settings.)

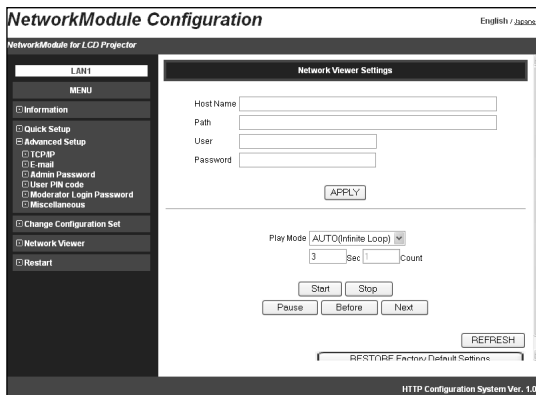

### 3) Operating with the projector

Before operating the Network Viewer from the projector, the FTP server needs to be configured by PJ Controller or browser in advance.

Regarding the configuration of the FTP server, refer to “1) Operating with the PJ Controller” (pp.66–67) or “2) Operating with the browser” (pp.68–69).

1. Configure the FTP server which provides image data, referring to “Operating with the PJ Controller” or “Operating with the browser.”
2. Select “Wireless” for Wireless LAN and “Wired” for Wired LAN for the input source of the projector.
3. Select “Wireless Viewer” when using Wireless LAN or “Wired Viewer” when using Wired LAN from the projector menu. The Viewer Setting screen will appear.

#### [Wired LAN]

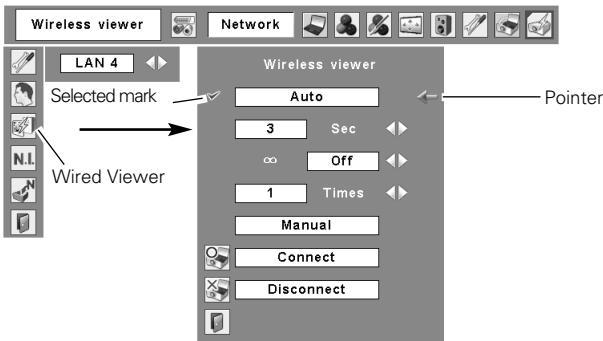

#### [Wireless LAN]

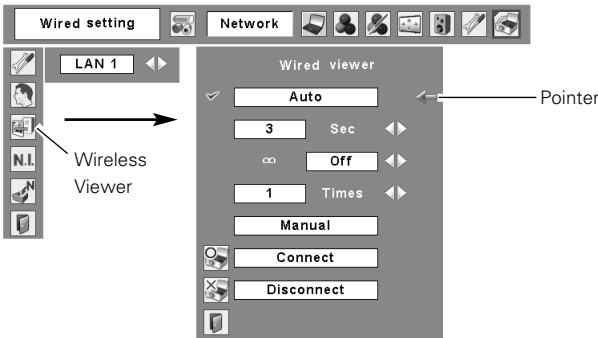

## 4. Select, execute, and stop the mode of image replay.

Move the red arrow pointer to the item you wish to choose.

Using Point buttons and SELECT button of the projector, configure or execute each item.

Auto .....Play images and stop playing according to following configurations.

Second .....Set timing to switch images in Auto play mode (3–240 sec.).

∞ .....Set "On" to make the projector keep playing images repeatedly.

Times .....Specify the number of repeating times of auto play (Maximum 255 times).

Manual .....Switch images manually.

Press the Point ▲ button on the projector (or the remote control) to show the next image and the Point ▼ button to show the previous image.

Connect to the FTP server

.....Move the red arrow pointer to "Connect" and press SELECT button on the projector (or the remote control) to connect the projector to the FTP server. Then the projector starts playing the images in the FTP server.

Disconnect from the FTP server

.....Move the red arrow pointer to "Disconnect" and press SELECT button on the projector (or the remote control) to disconnect the projector from the FTP server.





## 10. How to Use the PJ Controller

---

Control the projector operation on the network.

PJ Controller works for:

- Operating the projector
- Operating the Network viewer
- Controlling the projector
  - Monitor the operation status of the projector in real time.
  - Send an e-mail to the administrator about operation status of the projector.
- Operating multiple projectors simultaneously.  
(Multi Control)

# 10. How to Use the PJ Controller

## How to Operate

This operation requires that the projector is set correctly on the network and the image in the computer is properly displayed from the projector with "NetworkModule Client" or "NetworkModule Moderator" applications on the computer.

Activate the PJ Controller.

1. Activate the "NetworkModule Client" or " NetworkModule Moderator".
2. Select the Advanced settings screen.
3. Select a projector from the Network Projector List. (Selected Projector name will be blue.)  
You can select and operate one projector only. Multiple projectors cannot be operated. If you select and execute multiple projectors, another function screen (Multi Control Screen. See pages 89–90) will appear.
4. Click the PJ Controller button then the PJ Controller screen will appear.  
Left side of the screen is the Operation Item Selection Screen.  
Right side of the screen is the Screen for Adjustment.  
First, Initial Setting Menu will appear. Before using PJ Controller, set the items on this screen.
5. To terminate PJ Controller, select "Exit" from "File" in the tool menu.

\* The projector cannot be connected to via the networks while using the viewer.

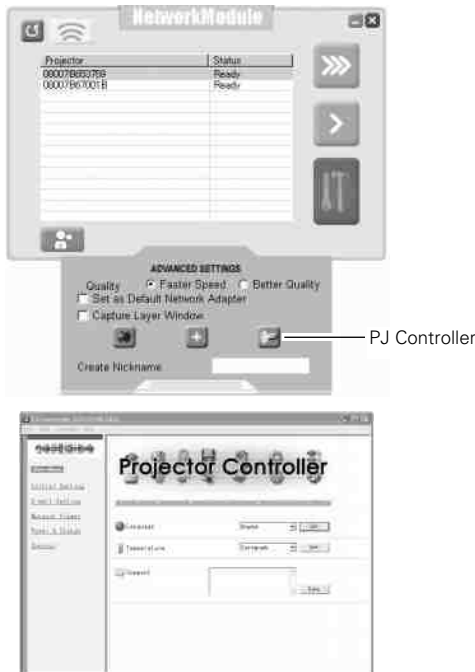

## Initial Settings

Before using the PJ Controller function, initial setting is required.

1. Select Initial Setting from the main menu and configure each item.



Parameter	Description
Language .....	Select a desired language from the pull-down menu, and click "Set".
Temperature .....	Set the unit of temperature displayed on the control screen of the projector. Select "Centigrade" or "Fahrenheit" from the pull-down menu and click "Set".
Comment .....	You can store any comments regarding the initial settings. To save the comments you entered, click "Save".

## E-mail Setting

The projector has a function to send an e-mail to inform its operating condition to the administrator or users. Select E-mail Setting from the main menu and configure each item as follows:



### 1. Registering E-mail Address

Parameter	Description
SMTP Server .....	Enter the address of SMTP server and click "Set".
Administrator Address .....	Enter the E-mail address of administrator and click "Set".
Mail Address .....	Enter E-mail addresses of users and click "Set". To delete the E-mail address, click "Delete".
Option.....	When the checked item has occurred, the projector sends alert messages.

\* The SMTP server is a server for sending E-mail. Please contact your network administrator to have this SMTP server address.

\* To use the E-mail function, the DNS address must be set correctly. (Refer to "6. Configurations with Browser" → "Advanced Setup" → "TCP/IP" (p.46).)

You cannot use this E-mail function if the SMTP server is not available in your network environment. If the SMTP server is located in your LAN (Local Area Network), the address set to SMTP server should be specified in SMTP server located in your LAN. The server located outside of your LAN may not be available for security reason. For further information, please contact your network administrator.

## 2. Check Option items

Check the conditions where you would choose the projector to send an alert message.  
Regarding the alert message, see samples below.

## 3. Enter the message to attach the E-mail.

The message typed here will be attached to the alert message.

## Samples of Alert Message

### \* When the internal temperature is too high

TITLE: Message from projector  
Projector Model Name: XX100  
TCP/IP: 192.168.0.111 Projector Name:

It sends you following message.

- \* The Projector lamp is turned off, because internal projector temperature is too high.  
Wait for the Temperature Warning Indicator to be turned off, and then turn the Projector on again.  
If the Indicator continues flashing, check the air filter for dust accumulation.

"A" 21.5degrees centigrade "B" -13.7degrees centigrade "C" 51.6 degrees centigrade  
Temperature of Sensor B is too high.  
Temperature of Sensor C is too high.

- \* The Network projector let users know the information which thermal sensor "A," "B," or "C" inside the projector detected the abnormal temperature risen and so the projector was turned off. Please refer to the item "Check the status of projector" for the location of the sensors "A," "B," and "C," and temperature (p.79). Also see the owner's manual of the projector for further details.

### \* When the internal power is failed

TITLE: Message from projector  
Projector Model Name: XX100  
TCP/IP: 192.168.0.111 Projector Name:

It sends you the following message.

- \* The Projector lamp is turned off, because projector power circuit is failed.  
Unplug this projector from AC outlet and ask for servicing to qualified service personnel.
- \* The Projector lamp was turned off, because the projector power is failed.  
Unplug the projector from AC outlet and ask servicing to a qualified service personnel

### \* When the life of the lamp has been expired

TITLE: Message from projector  
Projector Model Name: XX100  
TCP/IP: 192.168.0.111 Projector Name:

It sends you the following message:

- \* The life span of lamp is reached. Lamp replacement is required.

- \* Replace it with a new lamp immediately and reset the lamp counter. If the projector is used without resetting the lamp counter, the alert e-mail will be sent every time turning on the projector.

### \* When the time to clean filter comes

Warning mail will be sent when the time to clean filter comes. Time is set in the Filter counter.

## Power & Status

Click “Power & Status” on the main menu and configure each item.

### 1. Turning on/off the projector

Click Standby/ON buttons. When clicking the Standby button, the confirmation message will appear. Click OK to turn off the projector.

CAUTION: Projector cannot be turned on for approximately 90 seconds after it being turned off. When the display of “Power Status” changes from “On cooling down” to “On”, click ON to turn on the projector.

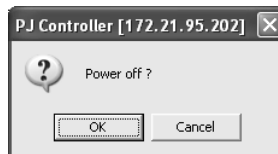
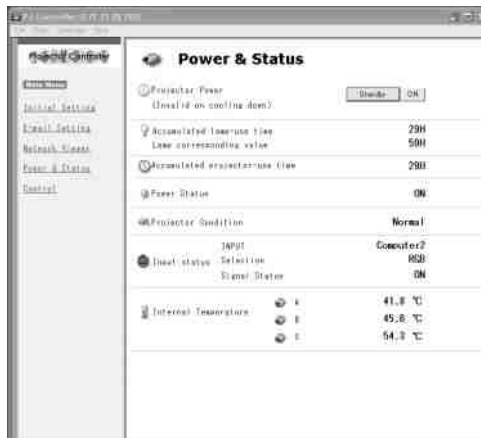

### Caution about turning on/off the projector via the networks

When you wish to turn on/off the projector via the networks, preset the projector as follows:

1. Select “Setting” from the Projector menu.
2. Select “Standby mode” from the Setting menu and set it as “Normal”.

If you set this function as Normal, the network part of the projector is constantly provided with power even if the projector is turned off. If you set this as Eco, then the network part will be turned off when you turn off the projector. Consequently, you cannot turn on/off the projector via the networks.

## 2. Check the status of the projector

The following items can be checked on the Power & Status screen.

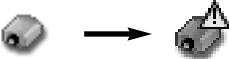
Parameter	Description
Accumulated lamp-use time.....	Display the accumulated time of lamp use in hour increment.
Accumulated projector-use time ....	Display the accumulated time of projector use in hour increment.
Power Status .....	Display the status of the projector's lamp as follows: "On", "Off", "Standby", "Power Saver Mode/On cooling down", "Temperature Error/On cooling down", "On starting up", "On power management operating", "Temperature Error/Standby".
Projector Condition.....	Display the projector's condition as follows: "Normal", "Temperature Error", "Power Failure".
Input Status .....	Display the following input status
Input.....	Display the selected input mode.
Selection .....	Display the selected input source mode.
Signal Status .....	Display the signal status.
Internal Temperature.....	Display the detected internal temperature of the projector. The icons A, B, and C stand for the thermal sensors inside the projector. If the internal temperature exceeds the certain point, each icon changes as below and let users know the error. Check the air filters and surrounding area of exhaust and intake vents of the projector.
	
	Icon A, B, and C are located as follows: A: Ambient temperature of the projector B: Ambient temperature of the panel C: Ambient temperature of the lamp
	* The ambient temperature of the projector may be shown a little higher than the actual temperature.

## Control

When you select Control from the main menu, Control Menu will appear at the bottom of the screen. Using this menu, you can adjust or configure the projector.

Note: Control items displayed on this screen are varied depending on the input source or product model of the projector. So the figures shown in this section may be different from the actual screen displayed on your computer. For further details, refer to the owner’s manual of your projector. This function is not available if the projector is turned off.

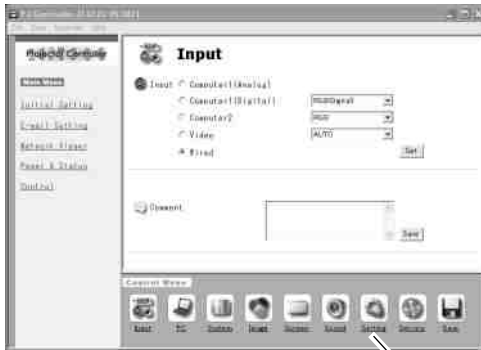

### Input

Control Menu

On this screen, you can select an input source of the projector. Check the input terminal and select the signal mode from the pull-down menu. Click Set button to switch the input. You can save a note in Comment field. Click Save button to save the note.

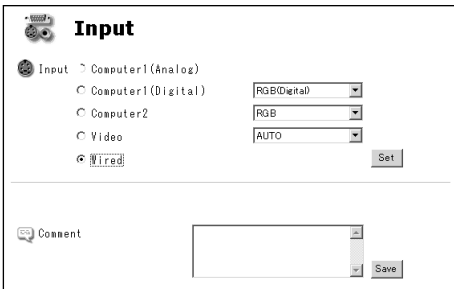

Parameter	Description
Wireless/Wired.....	Select this input when using the Screen Capture or the Network Viewer function.
Computer 1 (Analog).....	Select the computer analog input.
Computer 1 (Digital).....	Select the input source from "RGB(Digital)" or "RGB(AV HDCP)".
Computer 2.....	Select the input source from "RGB", "Component", and "RGB (Scart)".
Video.....	Select the input source from "AUTO", "VIDEO", and "S-VIDEO".





## PC adjustment

This feature optimizes the signal from the connected computer to display the screen.

\* PC adjustment screen is displayed only when Computer1 (Analog) or Computer 2 (RGB) is selected for the input source.

The screenshot shows the 'PC Adjustment' interface. At the top, it displays 'Current Mode' as 'XGA1'. Below this is an 'Auto PC adjustment' section with a 'Start' button. The main area contains several adjustable parameters, each with a numerical value, a small input field, and left/right arrow buttons, followed by a 'Set' button. These parameters are: 'Fine sync' (16), 'Total dots' (1344), 'H Position' (297), 'V Position' (35), 'Clamp' (1), 'Display Area H' (1024), and 'Display Area V' (768). There are also dropdown menus for 'Load Setting No.' and 'Save Setting No.', with a 'Mode free' button next to the latter. At the bottom, there is a 'Comment' text area with a 'Save' button.

Parameter	Description
Current Mode	.....Display computer mode
Auto PC adjustment	.....Executed by clicking Start button.
Fine sync	.....Click ◀▶ to adjust the value
Total dots	.....Click ◀▶ to adjust the number to fit your computer image.
H Position	.....Click ◀▶ to adjust the horizontal position.
V Position	.....Click ◀▶ to adjust the vertical position.
Clamp	.....Click ◀▶ to adjust the clamp level.
Display Area H	.....Click ◀▶ to decrease/increase the value to fit resolution of the image.
Display Area V	.....Click ◀▶ to decrease/increase the value to fit resolution of the image.
Load Setting No.	.....Load the preset settings (Mode 1–5)
Save Setting No.	.....You can save the settings of the PC adjustment. Select the mode number you wish to save and click "Set". * If you want to delete the content in the mode. Select the mode and click "Mode free".
Comment	.....You can save a note regarding the PC adjustment. Click "Save" to save the note.



## SYSTEM Adjustment

On this screen, you can select the color system and scan mode for the video signal. This screen is displayed only when Video (Video/Component) is selected for the input source of the projector. Depending on the signal, the screen is varied as follows.

### Component Input

**SYSTEM Adjustment**

SYSTEM Adjustment

AUTO       1080i       1035i  
 720p       575p       480p  
 575i       480i

Parameter	Description
System Adjustment .....	Select a scan mode of component signal.
AUTO .....	Automatically adjust to the scan mode of the input signal.

### VIDEO/S-VIDEO Input

**SYSTEM Adjustment**

Color System Adjustment

AUTO       PAL       SECAM  
 NTSC       NTSC4.43       PAL-M  
 PAL-N

Parameter	Description
Color System Adjustment .....	Select a color system of Video/S-Video signal.
AUTO .....	Automatically adjust to the color system of the input signal.

NOTE: Items in System Adjustment are displayed only for video input (video/Component).



## Image Adjustment

On this screen, you can adjust the image projected from the projector. Select an Image Adjustment Mode from the pull-down menu and click Set button. The items displayed on this screen is automatically changed according to the input signal. Click ◀▶ buttons to adjust the value. Every time you change the value, click Set button. If you click Reset button, all the adjusted values will be reset.

\* Some items may not be adjusted depending on the functions of your projector or input signal. In this case, “—” will be shown in the field of the item.

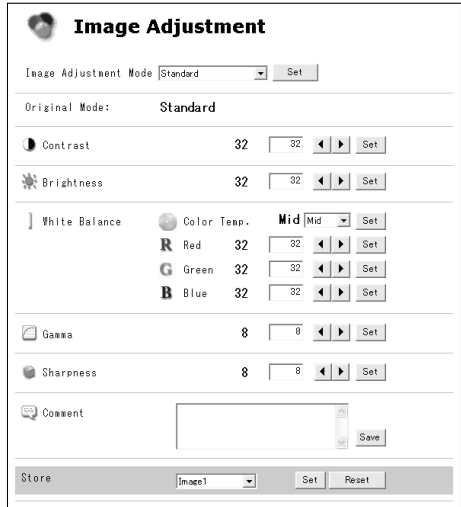

Parameter	Description
Image Adjustment Mode.....	Select from “Dynamic”, “Standard”, “Real*”, “Cinema**”, “Black Board”, “Image 1–4”, from the pull-down list. Image 1–4 can be set by users.
Original Mode .....	Displays the original mode.
Contrast .....	Click ◀▶ to adjust the image contrast.
Brightness .....	Click ◀▶ to adjust the image brightness.
Tint** .....	Click ◀▶ to obtain a proper image.***
Color** .....	Click ◀▶ to adjust the color intensity.
White Balance	
Color Temp. ....	Click ◀▶ to adjust the color temp level (XLow, Low, Mid, or High).
Red, Green, Blue .....	Click ◀▶ to adjust white balance of the image.
Gamma .....	Click ◀▶ to obtain a better balance of contrast.
Sharpness .....	Click ◀▶ to adjust the image sharpness.
Noise Reduction** .....	Set the Noise Reduction function.
Progressive** .....	Switch progressive mode: “Off”, “L1” (motion picture), “L2” (still picture), Film
Comment.....	You can save a note regarding Image Adjustment. Click “Save” to save the note.
Store .....	You can save the settings of the Image Adjustment. Select the mode number you wish to save and click Set button. If you click “Reset”, all the adjusted values will be reset.

\* Items only for computer input.

\*\* Items only for video input.

\*\*\* If the color system is PAL, SECAM, PAL-M, or PAL-N, tint cannot be adjusted.



## Screen

You can select a screen mode on this screen. The items displayed on this screen is automatically changed according to the input signal.



Parameter	Description
Aspect.....	Select "Normal", "True*", "Wide", "Full screen*", and "Custom".
Digital Zoom* ....	Click "+" or "-" button to enlarge or minimize the screen size. Click "OFF" to cancel this function.
* Items only for Wireless, Wired Computer1 (Analog) or Computer2 (RGB) input mode.	

\* If "1080i", "1035i", or "720p" scan mode is selected from "System Adjustment" (Y, Pb/Cb, Pr/Cr input only) setting in "SYSTEM" screen, you cannot configure "Screen" settings.



## Sound

On this screen, you can adjust the sound volume of the projector.

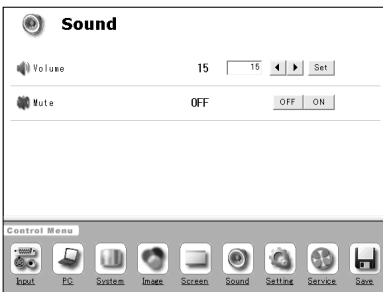

Parameter	Description
Volume .....	Click ◀▶ to adjust the volume.
Mute .....	Click "ON" to mute the sound and "OFF" to cancel this function.



## Setting

On this screen, you can configure the projector. Refer to the next page for each item and description.

The items displayed on this screen are varied according to the functions provided to the projector.

Setting	
Language	Japanese <input type="button" value="Set"/>
Auto Setup	
Auto PC Adjust	ON <input type="button" value="ON"/> <input type="button" value="Set"/>
Auto Keystone	Auto <input type="button" value="Auto"/> <input type="button" value="Set"/>
<input type="button" value="Start"/>	
Keystone	
	<input type="button" value="▲"/> <input type="button" value="OFF"/>
	<input type="button" value="▼"/> <input type="checkbox"/> High Speed
	Store <input type="button" value="Reset"/> <input type="button" value="Store"/>
Blue Back	ON <input type="button" value="OFF"/> <input type="button" value="ON"/>
Display	ON <input type="button" value="ON"/> <input type="button" value="Set"/>
Loop Select	Default <input type="button" value="Default"/> <input type="button" value="Set"/>
Capture:	Capture? <input type="button" value="Yes"/>
Gelling	OFF <input type="button" value="OFF"/> <input type="button" value="ON"/>
Rear	OFF <input type="button" value="OFF"/> <input type="button" value="ON"/>
Input Search	OFF <input type="button" value="OFF"/> <input type="button" value="ON1"/> <input type="button" value="ON2"/>
Standby Mode	Economy <input type="button" value="Normal"/> <input type="button" value="Eco"/>
No Show	OFF <input type="button" value="OFF"/> <input type="button" value="ON"/>
Freeze	OFF <input type="button" value="OFF"/> <input type="button" value="ON"/>
Power Management	Ready <input type="button" value="Ready"/> <input type="button" value="min."/> <input type="button" value="Set"/>
On Start	OFF <input type="button" value="OFF"/> <input type="button" value="ON"/>
Loop Control	Auto <input type="button" value="Auto"/> <input type="button" value="Set"/>
Pointer	Spotlight-M <input type="button" value="Spotlight-M"/> <input type="button" value="Set"/>
Remote Control	Code 1 <input type="button" value="Code1"/> <input type="button" value="Set"/>
Key Lock	None <input type="button" value="None"/> <input type="button" value="Set"/>
Fan	L-2 <input type="button" value="L-1"/> <input type="button" value="L-2"/>
Fan Control	Normal <input type="button" value="Normal"/> <input type="button" value="Max"/>
Loop Counter	Reset? <input type="button" value="Yes"/>
	26H
Filter Counter	Reset? <input type="button" value="Yes"/>
	13H

## 10. How to Use the PJ Controller

Parameter	Description
Language .....	Select the desired language from the pull-down menu.
Auto Setup .....	Automatically set PC adjustment and correct keystone distortion. Auto PC Adjust. ...Select "On" to automatically set the PC adjustment. Auto Keystone .....
	Select Auto to automatically correct keystone distortion, and select "Manual" to set keystone distortion when the Auto set button is clicked.
Keystone .....	Press the ▲▼ buttons to correct keystone distortion. Check the High Speed box if you wish to increase the variation. Click OFF if you do not need this function.
Blue Back.....	Select "ON" or "OFF" to display/hide blue background when no signal is detected.
Display .....	Select "ON", "OFF", or "Count Down Off" to display/hide the screen.
Logo Select.....	Select the image to show on the starting-up display from "User", "Default", or "OFF".
Capture .....	Click "YES" to capture the projected image. The captured image can be used for the starting-up display. (Select User for Logo.)
Ceiling .....	By clicking "ON", the image gets reversed vertically and horizontally to adjust to ceiling-mount projection.
Rear .....	By clicking "ON", the image gets reversed horizontally to adjust to rear projection.
Input Search.....	You can set automatic selection mode for Input Search.
Standby Mode .....	Click "Normal" or "Eco" to set the Standby Mode of the network.
No Show .....	By clicking "ON", the image will be temporarily hidden from view.
Freeze .....	By clicking "ON", the image will temporarily freeze.
Power Management .....	Select "Ready", "Shut Down", or "OFF" from the pull-down menu. Enter the count-down time by clicking ◀▶ buttons.
On Start .....	By clicking "ON", the projector will be automatically turned on when the power plug is connected to AC outlet.
Lamp Control .....	Select the Lamp Mode from "Auto", "High", "Normal", and "Eco".
Pointer .....	Select the shape of the Pointer from "Spotlight-S", "Spotlight-M", "Spotlight-L", "Pointer", "Finger", and "Laser".
Remote Control .....	Select Remote Control Code from Code1 to Code 8. If you change the code here, you have to change the code of the remote control product at the same time.
Key Lock .....	To lock the projector, select "Projector Keys" (Locks the top panel operation) or "Remote Control" (Locks the remote control operation). If you do not need to lock, select None.
Fan .....	Adjust the rotating speed of the cooling fans. "L1" is normal and "L2" is slower and quieter mode.
Fan Control .....	You can choose running speed of the cooling fan.
Lamp Counter .....	You can reset the lamp counter. Reset the lamp counter only when you change the lamp.
Filter Counter .....	You can set the length of time to use the filter. You can also reset the Filter Counter. Reset only when you clean filter or replace filter.
Factory Default .....	If you wish to reset all the values you set in the control menu, click "Yes".
P-TIMER .....	When you click "P-TIMER", the timer will appear on the projected screen. Click again and the elapsed time will appear. Click again and the timer will disappear.



## Service

Items on this screen are used for maintenance of the projector.



Parameter	Description
Video System	Display scanning system of video signals. "No items are shown in the current input mode" will be displayed in other signals.

\* If you select Wired, Wireless Computer1 (Analog/Digital) or Computer 2 (RGB) for the input source, these items are not shown.



## Save Actual Adjustment

On this screen, you can save and load the setting. The items you can save are as follows: Input, PC adjustment, System Adjustment, Image Adjustment, Screen and Setting.

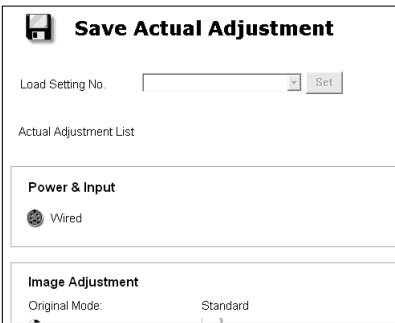

\* The figure shows only a part of the full screen.

### 1. Confirm the actual adjustment

When you click Save icon in the Control Menu, the "Save Actual Adjustment" screen will appear. Check each setting. (Go to the next page.)

## 2. Select Set Number and name the setting

Select the Set Number you wish to store the adjustment from the pull-down menu.  
Enter the name of the setting in the Memo field.

Store Adjustment

Save to: **Set 1** Memo:  **Save**

Set 1  
Set 2  
Set 3  
Set 4  
Set 5  
Set 6

Enter the name of the setting

## 3. Save the setting (Set)

Click Save button to save the adjustment.

## Loading the Set

Click the pull-down menu of Load Setting No. and select the set number you wish to load.  
Click Set button to display the value of the set.

**Save Actual Adjustment**

Load Setting No. **Set 1 (test-1)** **Set**

Actual Adjustment List

Set 1 (test-1)  
Set 2 (test-2)  
Set 3 (test-3)  
Set 4 (test-4)  
Set 5 (test-5)

**Power & Input**

Wired

Select the set number from the pull-down menu.



## Multi Control

With this function, multiple projectors can be operated simultaneously.

You can operate up to 64 projectors at the same time.

With this function, you can also operate the projector which is attached a MultiCard Imager and on the same network.

### Operation

1. Activate NetworkModule Client (or NetworkModule Moderator), and call up the Advanced Settings screen.
2. Select the projectors to operate by the mouse pointer with pressing the [Ctrl] key or the [Shift] key of the computer. The illustration of PJ Controller/Multi Control button will be changed from one projector into two projectors.
3. Click the PJ Controller/Multi Control button to display the Multi Control screen.

\* When selecting only one projector in step 2, the PJ Controller screen will appear in step 3.

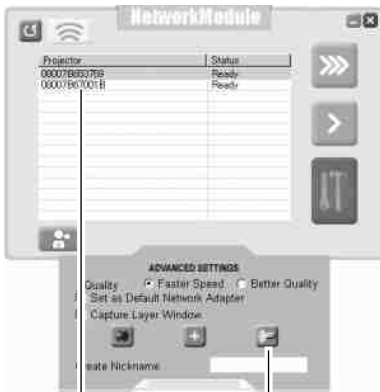

**Network Projector**  
Select multiple projectors.

**PJ Controller/  
Multi Control button**  
The illustration on the button will become two projectors.

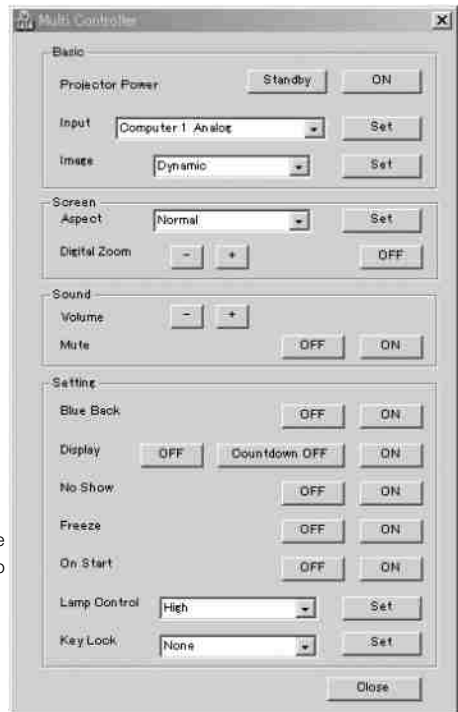

## 10. How to Use the PJ Controller

---

Parameter	Description
Projector Power .....	Turn on or off the projector. * When using the Multi Control function, set "Normal" from "Setting menu" → "Standby mode". If selecting "Eco", you cannot turn on the projector again after turning off.
Input.....	Select projector input.
Image.....	Select Image mode.
Aspect .....	Select aspect of the screen.
Digital Zoom.....	Zoom in or out the screen.
Volume.....	Adjust the volume of the speaker on the projector.
Mute .....	On or Off the Mute function.
Blue Back.....	Select "ON", to project blue screen when the input source is not detected.
Display .....	Select to display or not to display the On screen menu.
No Show .....	Select "ON" to display the blank screen.
Freeze .....	On or off the Freeze function.
On Start .....	Select to turn on or off the projector with the projector power source.
Lamp Control .....	Select the brightness of the screen.
Key Lock .....	Lock or Unlock the key operation of the projector and the remote control.
* Items with "SET" button requires to click "SET" to be effective.	
NOTE :Items to adjust differ depending on the projector. With some projectors these functions may not work properly.	

## 11. Appendix

---

- Troubleshooting
- Terminology
- Setting up IP Address with arp + ping Command

# 11. Appendix

---

## Troubleshooting

---

If you have any trouble in setup or operation of the projector, refer to the troubleshooting items and check the relevant matters described.

### ■ The computer cannot connect projectors.

#### Wired LAN

- Is the LAN cable connected to the projector properly?
- Are the Link lamp and Access lamp of the LAN terminal lighting properly?
  - Not lighting : The LAN setting of the projector is set "On"?
  - See "Wired LAN setting" in the projector menu.
  - The LAN cable is connected to the network HUB properly?

#### Wireless LAN

- Is the USB Wireless LAN Adapter attached to the USB terminal of the projector and USB lamp is blinking? If there are not any problems, confirm the LAN setting again.
- If the computer supports Wireless LAN, activate NetworkModule Client (or NetworkModule Moderator) and try to connect with the Easy setting button. Refer to "5. Wireless LAN configuration" → "Easy settings" (pp.36–37).

### ■ Wireless LAN Connection cannot be established.

#### AdHoc Mode:

When selecting LAN4(factory default setting)

Check each item in the Wireless Setting menu of the projector as follows:

- \*IP Address .....Is the address appropriate? Should not be same as the other IP address.
- \*Sub net .....Should be the factory default value, 255.255.0.0.
- \*Gateway .....Should be the factory default value, 255.255.255.255
- \*Network Type....Should be AdHoc mode
- \*ESSID/SSID/IBSSID  
.....Should be the same as the setting of computer  
->Check the setting for the computer
- \*Is the Wireless channel set as 11 both for the computer and the projector?  
->The factory default channel of the projector is 11.
- \*WEP (Wired Equivalent Privacy)  
.....Should be disabled.  
To enable the function, set the WEP by the browser after the connection is established.  
(Refer to "6. Configurations with Browser" on page 47.)

**Infrastructure Mode:**

When selecting LAN5 (factory default setting)

Check each item below in the Wireless Setting menu of the projector as follows:

- \* IP Address .....No setting is required.
- \* Sub net .....Should be same as the setting of the access point
- \* Gateway.....Should be same as the setting of the access point
- \* Network Type .....Should be the Infrastructure mode
- \* ESSID/SSID/IBSSID....Should be same as the setting of the access point

Check the settings for projector Client computer

- \* IP Address .....No setting is required. Automatically set as HDCP.
- \* Wireless Channel.....Should be 11
- \* ESSID/SSID/IBSSID....Is same as the setting of the access point?
- \* WEP.....Should be disabled.  
->To enable the function, set the WEP by the browser after the connection is established. (Refer to “6. Configurations with Browser” on page 47.)

\* When using LAN5, it is necessary DHCP/BOOTP server is under the environment enabling those servers communicate through networks. Some access points may have the DHCP function. For detail of the settings, refer to the owner’s manual for the devices or consult a system administrator of the network.

-----  
Is the segment where the projector is installed different from the computer?  
Specify IP Address directly on the optional setting. Refer to “4. Wired LAN Configurations” → “Confirming the Operation” (p28–29).

## ■ Connection between computer and the projector via Wired LAN cannot be established.

When selecting LAN1 (factory default setting)

Check IP address, Sub net and Gateway of the projector and computer. For further details of the configuration, contact your system administrator.

-----  
Is the segment where the projector is installed different from the projector?  
Specify IP Address directly on the optional setting. Refer to “4. Wired LAN Configurations” → “Confirming the Operation” (pp.28–29).

### About Settings for LAN Environment:

When setting LAN4 or LAN5, first, connect to the projector with easy settings and set with the browser. Or connect client computer to the projector in accordance with the factory default settings. Make detailed settings by the browser and then restore the computer for previous environment setting.

■ **Cannot start up the browser**

Is connection between PC and the projector with NetworkModule Client (or NetworkModule Moderator) established?

No.....Check settings for Wireless/Wired LAN.

Yes .....Check settings of the proxy setting at browser. Refer to “6. Browser Configuration” (p.40).

■ **Although connection between PC and the projector is established, images are not projected on the screen.**

Make sure Wireless/Wired is selected from the Input source menu of the projector.

■ **The projector/PJ Controller cannot be turned on/off.**

Make sure the settings of the projector are correct to use the projector with it.

Refer to “10. How to Use the PJ Controller” → “ Power & Status” (pp.78–79).

■ **Network Viewer does not work with the projector operation.**

Make sure the FTP server setting. You need to set the FTP server in advance.

Refer to “9. How to Use Network Viewer” → “3)Operating with the projector” (pp.70–71).

■ **Speed of playing back images are very slow.**

When connecting on AdHoc mode, check which Wireless channel you are using.

If the computer using the same channel as yours is existing closely, the networking speed may be diminished or the communication unstable. Change channel to resolve the problem.

The channels of the projector and projector Client computer must be the same. Or adjust the Quality selection in the Advanced settings.

Refer to “7. Project the Image via the Networks” (p.56).

■ **Wired/Wireless input cannot be changed.**

**NetworkModule Client (or NetworkModule Moderator) cannot be operated.**

After selecting “Setting menu” → “factory default” in the projector menu, all the projector and network settings you have made (such as password or projector name etc.) will go back to the factory default settings.

## Terminology

---

### DHCP server (Dynamic Host Configuration Protocol)

It is necessary to set an IP address for each computer or equivalent equipment when establishing a network by TCP/IP. If there exists DHCP server on the network, it will assign IP addresses to client computers every time they request it. If there exists equipment with DHCP server functions (such as a Windows 2000 server and a dial-up router) on the network, the DHCP server function may be automatically operating. Ask your system administrator whether the DHCP server is operating.

### ESSID (Extended Service Set Identifier)

ESSID is the ID that is set to computers on Wireless LAN or access point in order to prevent each computer from being crossed. The computers or access point to which the same ESSID is set can communicate with each other. If an ESSID is different, it is impossible to communicate. ESSID distinguishes between lowercase and uppercase characters, and allows you to use English one byte characters and half-size symbols up to 32 characters.

### WEP (Wired Equivalent Privacy)

WEP is a security protocol for Wireless LAN. It protects computers on Wireless LAN and access point from unauthorized access by setting a decryption code onto them. It is necessary to set the same decryption code for equipment.

### Wi-Fi (the Standard for Wireless Fidelity)

Wi-Fi is short for Wireless fidelity and a marketing brand name for IEEE 802.11b High-Rate. Only the products that have passed an inter-operation test carried by WECA is approved as Wi-Fi. Any products approved as Wi-Fi are certified as interoperable with each other by WECA. It is recommended to use the products approved by Wi-Fi when introducing network equipment such as local area network.

### Wireless Channel

It is necessary to divide frequency spectrums into some Wireless channels for Wireless communication, and to tune to the same channel between Wireless equipment. If you use the same channel on the same floor, and there are some Wireless LANs that have a different ESSID for each, the communication speed may become slow. In this case, using different channels for each Wireless LAN is effective, and lowers a possibility of mutual interference between Wireless LANs

### WECA (Wireless Ethernet Compatibility Alliance)

WECA is an organization promoting IEEE802.11b High -Range standard and assuring the compatibility of products that meet the standard.

### MAC address (Media Access Control Address)

MAC address is a physical address for every network interface. The MAC address consists of 6-byte hex number. The first 3 bytes are a Vendor ID controlled and assigned by IEEE. The last 3 bytes are controlled and assigned by the manufacturers of network interface (no duplication of MAC address). Therefore, MAC address is a unique physical address in the world. Ethernet sends and receives frames on the basis of MAC address.

## Setting up the IP address with "arp" + "ping" command

You can use "arp" and "ping" command from Command Prompt to assign an IP address to your projector.

1. Start up projector and configure the Wired or Wireless LAN to communicate with the computer.
2. From Windows "Start" menu, click "Run". In the field next to "Open:", enter "command" and click OK. When "MS-DOS prompt" (or command prompt) appears, type in "arp" command as follows:

(Example)

```
C:\> arp -s 169.254.1.100 00-c0-6f-05-1c-c2
```

—— Indicates an IP address you wish to assign to your projector.

----- Separates MAC address of your projector product every two characters by hyphen.

MAC address is indicated on a label attached to the bottom of each unit.

3. Next, enter "ping" command as follows:

(Example)

```
C:\> ping 169.254.1.100 (by executing ping command, the IP address will be set)
```

—— Indicates an IP address you wish to assign to your projector.

**Reply from 169.254.1.100:bytes=32 times=2ms TTL=255**

(if this message appears, the IP address was successfully assigned to projector)

Note: The assigned IP address is saved in the firmware of projector, thus it will remain set even when the power is off. You can use the same method to re-assign an IP address.

If "arp+ping" option ("6, Configurations with Browser" → "Advanced Setup" → "TCP/IP" (p.46)) is disabled in TCP/IP setting of the projector, you cannot assign an IP address using "arp" and "ping" commands. (In factory default state, "arp+ping" is set to "Enable").



## Configuring WEP security with the projector

Configure WEP security with the projector by following the steps below.

After configuring the network in “5. Wireless LAN Configurations” (pp.34–36), select “Next” in the LAN setting screen (see page 35). The WEP configuration screen appears. Refer to “6. Configurations with Browser” → “Wireless Setting” (p.47) as well.

**LAN 4** Wireless setting

IP address

Subnet

Gateway

Network type

SSID/ESSID/IBSSID

A	B	C	D	E	F	G	H	I	J	K	L	M	N	O	P
Q	R	S	T	U	V	W	X	Y	Z	a	b	c	d	e	f

1. Use the Point ▲▼ buttons to select the WEP security type. To disable WEP security, select “Disable.”

Although you can enable LEAP, you must enter the Key index code for LEAP with the browser.

Use the Point ◀▶ buttons move among the items; use the Point ▲▼ buttons to adjust settings.

WEP configuration screen

**LAN 4** Wireless setting

WEP security

Key Index

#1

#2

#3

#4

2. Select "Key index". Use the Point ▲▼ buttons choose the HEX or ASCII key. The four (#1-#4) kinds of WEP keys can be configured. Use the Point ◀▶ buttons to move to the right frame; use the Point ▲▼ buttons to select a WEP key number (#1-#4).
3. Use the Point ◀▶ buttons to select the Type field of the WEP key number that corresponds to the one you selected above and press the SELECT button. The WEP key entry screen appears. In the WEP key entry field, all characters are displayed in "\*". Use the Point ▲▼ buttons to select a character; use the Point ◀▶ buttons to select a character position. Enter all the character count displayed with "\*".

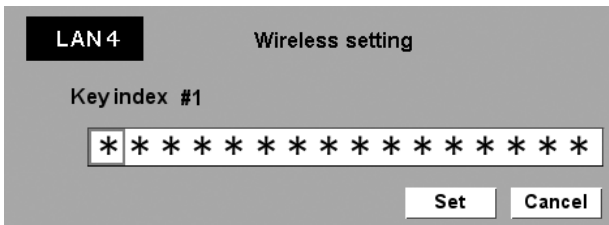

4. Use the Point ◀▶ buttons to select "Set" and press the SELECT button to return to the Wireless setting screen. Select "Set" in the Wireless setting screen to complete.

Notes when entering characters:

The "¥" symbol is displayed as "\" when using the ASCII key\*. The "\*" symbol is treated as a character by the ASCII key, but it is not interpreted as a character by the HEX key\*\*. In HEX, the "\*" symbol is displayed in red and setting is denied.

You can not set all the characters with the "\*" symbol. This will be considered as no operation and denied.

\*English characters generally used in computer keyboards.

\*\*HEX is in the range of 0-9 and a-f.

