

## Projector

# CP-X308

## User's Manual (detailed) Operating Guide

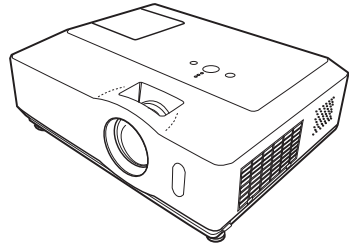

Thank you for purchasing this projector.

**⚠ WARNING** ▶ Before using this product, please read all manuals for this product. Be sure to read "Safety Guide" first. After reading them, store them in a safe place for future reference.

### About this manual

Various symbols are used in this manual. The meanings of these symbols are described below.

**⚠ WARNING** This symbol indicates information that, if ignored, could possibly result in personal injury or even death due to incorrect handling.

**⚠ CAUTION** This symbol indicates information that, if ignored, could possibly result in personal injury or physical damage due to incorrect handling.

 Please refer to the pages written following this symbol.

**NOTE** • The information in this manual is subject to change without notice.  
• The manufacturer assumes no responsibility for any errors that may appear in this manual.  
• The reproduction, transfer or copy of all or any part of this document is not permitted without express written consent.

### Trademark acknowledgment

- Mac is registered trademarks of Apple Computer, Inc.
- VESA and SVGA are trademarks of the Video Electronics Standard Association.
- Windows is a registered trademark of Microsoft Corporation.

All other trademarks are the properties of their respective owners.

Projector

# User's Manual - Safety Guide

---

Thank you for purchasing this projector.



**⚠ WARNING** • Before using, read these user's manuals of this projector to ensure correct usage through understanding. After reading, store them in a safe place for future reference. Incorrect handling of this product could possibly result in personal injury or physical damage. The manufacturer assumes no responsibility for any damage caused by mishandling that is beyond normal usage defined in these manuals of this projector.

**NOTE** • The information in this manual is subject to change without notice.

- The manufacturer assumes no responsibility for any errors that may appear in this manual.
- The reproduction, transmission or use of this document or contents is not permitted without express written authority.

## About The Symbols

Various symbols are used in this manual, the user's manual and on the product itself to ensure correct usage, to prevent danger to the user and others, and to prevent property damage. The meanings of these symbols are described below. It is important that you read these descriptions thoroughly and fully understand the contents.

 <b>WARNING</b>	This symbol indicates information that, if ignored, could possibly result in personal injury or even death due to incorrect handling.
 <b>CAUTION</b>	This symbol indicates information that, if ignored, could result possibly in personal injury or physical damage due to incorrect handling.

## Typical Symbols



This symbol indicates an additional warning (including cautions). An illustration is provided to clarify the contents.



This symbol indicates a prohibited action. The contents will be clearly indicated in an illustration or nearby (the symbol to the left indicates that disassembly is prohibited).



This symbol indicates a compulsory action. The contents will be clearly indicated in an illustration or nearby (the symbol to the left indicates that the power plug should be disconnected from the power outlet).

# Safety Precautions

## WARNING

### **Never use the projector if a problem should occur.**

Abnormal operations such as smoke, strange odor, no image, no sound, excessive sound, damaged casing or elements or cables, penetration of liquids or foreign matter, etc. can cause a fire or electrical shock.

In such case, immediately turn off the power switch and then disconnect the power plug from the power outlet. After making sure that the smoke or odor has stopped, contact your dealer. Never attempt to make repairs yourself because this could be dangerous.

- The power outlet should be close to the projector and easily accessible.

### **Use special caution for children and pets.**

Incorrect handling could result in fire, electrical shock, injury, burn or vision problem.

Use special caution in households where children and pets are present.

### **Do not insert liquids or foreign object.**

Penetration of liquids or foreign objects could result in fire or electrical shock.

Use special caution in households where children are present.

If liquids or foreign object should enter the projector, immediately turn off the power switch, disconnect the power plug from the power outlet and contact your dealer.

- Do not place the projector near water (ex. a bathroom, a beach, etc.).
- Do not expose the projector to rain or moisture. Do not place the projector outdoors.
- Do not place flower vases, pots, cups, cosmetics, liquids such as water, etc on or around the projector.
- Do not place metals, combustibles, etc on or around the projector.
- To avoid penetration of foreign objects, do not put the projector into a case or bag together with any thing except the accessories of the projector, signal cables and connectors.

### **Never disassemble and modify.**

The projector contains high voltage components. Modification and/or disassembly of the projector or accessories could result in fire or electrical shock.

- Never open the cabinet.
- Ask your dealer to repair and clean insides.

### **Do not give the projector any shock or impact.**

If the projector should be shocked and/or broken, it could result in an injury, and continued use could result in fire or electrical shock.

If the projector is shocked, immediately turn off the power switch, disconnect the power plug from the power outlet and contact your dealer.

### **Do not place the projector on an unstable surface.**

If the projector should be dropped and/or broken, it could result in an injury, and continued use could result in fire or electrical shock.

- Do not place the projector on an unstable, slant or vibrant surface such as a wobbly or inclined stand.
- Use the caster brakes placing the projector on a stand with casters.
- Do not place the projector in the side up position, the lens up position or the lens down position.
- In the case of a ceiling installation or the like, contact your dealer before installation.



Disconnect the plug from the power outlet.



Do not disassemble.



# Safety Precautions (continued)

## **WARNING**

### **Be cautious of High temperatures of the projector.**

High temperatures are generated when the lamp is lit. It could result in fire or burn. Use special caution in households where children are present.

Do not touch about the lens, air fans and ventilation openings during use or immediately after use, to prevent a burn. Take care of ventilation.

- Keep a space of 30 cm or more between the sides and other objects such as walls.
- Do not place the projector on a metallic table or anything weak in heat.
- Do not place anything about the lens, air fans and ventilation openings of the projector.
- Never block the air fan and ventilation openings.
- Do not cover the projector with a tablecloth, etc.
- Do not place the projector on a carpet or bedding.



### **Never look through the lens or openings when the lamp is on.**

The powerful light could adversely affect vision.

Use special caution in households where children are present.

### **Use only the correct power cord and the correct power outlet.**

Incorrect power supply could result in fire or electrical shock.

- Use only the correct power outlet depending on the indication on the projector and the safety standard.
- The enclosed power cord must be used depending on the power outlet to be used.



### **Be cautious of the power cord connection.**

Incorrect connection of the power cord could result in fire or electrical shock.

- Do not touch the power cord with a wet hand.
- Check that the connecting portion of the power cord is clean (with no dust), before using. Use a soft and dry cloth to clean the power plug.
- Insert the power plug into a power outlet firmly. Avoid using a loose, unsound outlet or contact failure.



### **Be sure to connect with ground wire.**

Connect the ground terminal of AC inlet of this unit with the ground terminal provided at the building using the correct power cord; otherwise, fire or electric shock can result.

- Don't take the core of power cord away.



Surely connect the ground wire.

# Safety Precautions (continued)

## **WARNING**

### **Be careful in handling the light source lamp.**

The projector uses a high-pressure mercury glass lamp made of glass. The lamp can break with a loud bang, or burn out. When the bulb bursts, it is possible for shards of glass to fly into the lamp housing, and for gas containing mercury to escape from the projector's vent holes.

**Please carefully read the section "Lamp".**

### **Be careful in handling the power cord and external connection cables.**

If you keep using a damaged the power cord or cables, it can cause a fire or electrical shock. Do not apply too much heat, pressure or tension to the power cord and cables.

If the power cord or cables is damaged (exposed or broken core wires, etc.), contact your dealer.

- Do not place the projector or heavy objects on the power cord and cables. Also, do not place a spread, cover, etc. over them because this could result in the inadvertent placing of heavy objects on the concealed power cord or cables.
- Do not pull the power cord and cables. When connecting and disconnecting the power cord or cables, do it with your hand holding the plug or connector.
- Do not place the cord near the heater.
- Avoid bending the power cord sharply.
- Do not attempt to work on the power cord.

### **Be careful in handling the battery of the remote control.**

Incorrect handling of the battery could result in fire or personal injury. The battery may explode if not handled properly.

- Keep the battery away from children and pets. If swallowed consult a physician immediately for emergency treatment.
- Do not allow the battery in a fire or water.
- Avoid fire or high-temperature environment.
- Do not hold the battery with the metallic tweezers.
- Keep the battery in a dark, cool and dry place.
- Do not short circuit the battery.
- Do not recharge, disassemble or solder the battery.
- Do not give the battery a physical impact.
- Use only the battery specified in the other manual of this projector.
- Make sure the plus and minus terminals are correctly aligned when loading the battery.
- If you observe a leakage of the battery, wipe out the flower and then replace the battery. If the flower adheres your body or clothes, rinse well with water.
- Obey the local laws on disposing the battery.



# Safety Precautions (continued)

## CAUTION

### **Be careful in moving the projector.**

Neglect could result in an injury or damage.

- Do not move the projector during use. Before moving, disconnect the power cord and all external connections, and close the slide lens door or attach the lens cap.
- Avoid any impact or shock to the projector.
- Do not drag the projector.
- For moving the projector, use the enclosed case or bag if provided.



### **Do not put anything on top of the projector.**

Placing anything on the projector could result in loss of balance or falling, and cause an injury or damage. Use special caution in households where children are present.



### **Do not attach anything other than specified things to the projector.**

Neglect could result in an injury or damage.

- Some projector has a screw thread in a lens part. Do not attach anything other than specified options (such as conversion lens) to the screw thread.



### **Avoid a smoky, humid or dusty place.**

Placing the projector in a smoke, a highly humid, dusty place, oily soot or corrosive gas could result in fire or electrical shock.

- Do not place the projector near a smoky, humid or dusty place (ex. a smoking space, a kitchen, a beach, etc.). Do not place the projector outdoors.
- Do not use a humidifier near the projector.



### **Take care of the air filter to normal ventilate.**

The air filter should be cleaned periodically. If the air filter becomes clogged by dust or the like, internal temperature rises and could cause malfunction. The projector may display the message such as "CHECK THE AIR FLOW" or turn off the projector, to prevent the internal heat level rising.

- When the indicators or a message prompts you to clean the air filter, clean the air filter as soon as possible.
- If the soiling will not come off the air filter, or it becomes damaged, replace the air filter.
- Use the air filter of the specified type only. Please order the air filter specified in the other manual of this projector to your dealer.
- When you replace the lamp, replace also the air filter. The air filter may be attached when you buy a replacement lamp for this projector.
- Do not turn on the projector without air filter.



### **Avoid a high temperature environment.**

The heat could have adverse influence on the cabinet of the projector and other parts. Do not place the projector, the remote control and other parts in direct sunlight or near a hot object such as heater, etc.



### **Avoid Magnetism.**

Manufacture strongly recommends to avoid any magnetic contact that is not shielded or protected on or near the projector itself. (ie., Magnetic Security Devices, or other projector accessory that contains magnetic material that has not been provided by the manufacture etc.) Magnetic objects may cause interruption of the projector's internal mechanical performance which may interfere with cooling fans speed or stopping, and may cause the projector to completely shut down.



# Safety Precautions (continued)

## CAUTION

### **Remove the power cord for complete separation.**

- For safety purposes, disconnect the power cord if the projector is not to be used for prolonged periods of time.
- Before cleaning, turn off and unplug the projector. Neglect could result in fire or electrical shock.

### **Ask your dealer to cleaning inside of the projector about every year.**

Accumulations of dust inside the projector cause result in fire or malfunction. Cleaning inside is more effective if performed before every humid periods such as rainy season.

- Do not clean inside yourself because it is dangerous.



Disconnect the plug from the power outlet.



## NOTE

### **Do not give the remote control any physical impact.**

A physical impact could cause damage or malfunction of the remote control.

- Take care not to drop the remote control.
- Do not place the projector or heavy objects on the remote control.

### **Take care of the lens.**

- Close the slide lens door or attach the lens cap to prevent the lens surface being scratched when the projector is not used.
- Do not touch the lens to prevent fog or dirt of the lens that cause deterioration of display quality.
- Use commercially available lens tissue to clean the lens (used to clean cameras, eyeglasses, etc.). Be careful not to scratch the lens with hard objects.

### **Take care of the cabinet and the remote control.**

Incorrect care could have adverse influence such as discoloration, peeling paint, etc.

- Use a soft cloth to clean the cabinet and control panel of the projector and the remote control. When excessively soiled dilute a neutral detergent in water, wet and wring out the soft cloth and afterward wipe with a dry soft cloth. Do not use undiluted detergent directly.
- Do not use an aerosol sprays, solvents, volatile substances or abrasive cleaner.
- Before using chemical wipes, be sure to read and observe the instructions.
- Do not allow long-term close contact with rubber or vinyl.

### **About bright spots or dark spots.**

Although bright spots or dark spots may appear on the screen, this is a unique characteristic of liquid crystal displays, and such do not constitute or imply a machine defect.

### **Be careful of printing of the LCD panel.**

If the projector continues projecting a still image, inactive images or 16:9 aspect images in case of 4:3 panel, etc., for long time, the LCD panel might possibly be printed.

# Safety Precautions (continued)

## NOTE

### **About consumables.**

Lamp, LCD panels, polarizers and other optical components, and air filter and cooling fans have a different lifetime in each. These parts may need to be replaced after a long usage time.

- This product isn't designed for continuous use of long time. In the case of continuous use for 6 hours or more, or use for 6 hours or more every day (even if it isn't continuous), or repetitious use, the lifetime may be shortened, and these parts may need to be replaced even if one year has not passed since the beginning of using.
- Any inclining use beyond the adjustment range explained in these user's manuals may shorten the lifetimes of the consumables.

### **Before turning on the power, make the projector cool down adequately.**

After turning the projector off, pushing the restart switch or interrupting of the power supply, make the projector cool down adequately. Operation in a high temperature state of the projector causes a damage of the electrode and un-lighting of the lamp.

### **Avoid strong rays.**

Any strong ray (such as direct rays of the sun or room lighting) onto the remote control sensors could invalidate the remote control.

### **Avoid radio interference.**

Any interfering radiation could cause disordered image or noises.

- Avoid radio generator such as a mobile telephone, transceiver, etc. around the projector.

### **About displaying characteristic.**

The display condition of the projector (such as color, contrast, etc.) depends on characteristic of the screen, because the projector uses a liquid crystal display panel. The display condition can differ from the display of CRT.

- Do not use a polarized screen. It can cause red image.

### **Turn the power on/off in right order.**

To prevent any trouble, turn on/off the projector in right order mentioned below unless specifying.

- Power on the projector before the computer or video tape recorder.
- Power off the projector after the computer or video tape recorder.

### **Take care not to fatigue your eyes.**

Rest the eyes periodically.

### **Set the sound volume at a suitable level to avoid bothering other people.**

- It is better to keep the volume level low and close the windows at night to protect the neighborhood environment.

### **Connecting with notebook computer**

When connecting with notebook computer, set to valid the RGB external image output (setting CRT display or simultaneous display of LCD and CRT).

Please read instruction manual of the notebook for more information.



# Lamp

## **WARNING**



HIGH VOLTAGE



HIGH TEMPERATURE



HIGH PRESSURE

The projector uses a high-pressure mercury glass lamp. The lamp can **break with a loud bang, or burn out**, if jolted or scratched, handled while hot, or worn over time. Note that each lamp has a different lifetime, and some may burst or burn out soon after you start using them. In addition, when the bulb bursts, it is possible for **shards of glass** to fly into the lamp housing, and for **gas containing mercury** to escape from the projector's vent holes.

**About disposal of a lamp** • This product contains a mercury lamp; do not put in trash. Dispose of in accord with environmental laws.

For lamp recycling, go to [www.lamprecycle.org](http://www.lamprecycle.org). (in USA)

For product disposal, contact your local government agency or [www.eiae.org](http://www.eiae.org) (in the US) or [www.epsc.ca](http://www.epsc.ca) (in Canada).

For more information, call your dealer.



Disconnect  
the plug from  
the power  
outlet

- If the lamp should break (it will make a loud bang when it does), unplug the power cord from the outlet, and make sure to request a replacement lamp from your local dealer. Note that shards of glass could damage the projector's internals, or cause injury during handling, so please do not try to clean the projector or replace the lamp yourself.
- If the lamp should break (it will make a loud bang when it does), ventilate the room well, and make sure not to breathe the gas that comes out of the projector vents, or get it in your eyes or mouth.
- Before replacing the lamp, make sure the power switch is off and the power cable is not plugged in, then wait at least 45 minutes for the lamp to cool sufficiently. Handling the lamp while hot can cause burns, as well as damaging the lamp.



- Do not open the lamp cover while the projector is suspended from above. This is dangerous, since if the lamp's bulb has broken, the shards will fall out when the cover is opened. In addition, working in high places is dangerous, so ask your local dealer to have the lamp replaced even if the bulb is not broken.
- Do not use the projector with the lamp cover removed. At the lamp replacing, make sure that the screws are screwed in firmly. Loose screws could result in damage or injury.



- Use the lamp of the specified type only.
- If the lamp breaks soon after the first time it is used, it is possible that there are electrical problems elsewhere besides the lamp. If this happens, contact your local dealer or a service representative.
- Handle with care: jolting or scratching could cause the lamp bulb to burst during use.
- Using the lamp for long periods of time, could cause it dark, not to light up or to burst. When the pictures appear dark, or when the color tone is poor, please replace the lamp as soon as possible. Do not use old (used) lamps; this is a cause of breakage.

# Regulatory Notices

## FCC Statement Warning

This device complies with part 15 of the FCC Rules. Operation is subject to the following two conditions: (1) This device may not cause harmful interference, and (2) this device must accept any interference received, including interference that may cause undesired operation.

**WARNING:** This equipment has been tested and found to comply with the limits for a Class B digital device, pursuant to Part 15 of the FCC Rules. These limits are designed to provide reasonable protection against harmful interference in a residential installation. This equipment generates, uses, and can radiate radio frequency energy and, if not installed and used in accordance with the instructions, may cause harmful interference to radio communications. However, there is no guarantee that interference will not occur in a particular installation. If this equipment does cause harmful interference to radio or television reception, which can be determined by turning the equipment off and on, the user is encouraged to try to correct the interference by one or more of the following measures:

- Reorient or relocate the receiving antenna.
- Increase the separation between the equipment and receiver.
- Connect the equipment into an outlet on a circuit different from that to which the receiver is connected.
- Consult the dealer or an experienced radio/TV technician for help.

**INSTRUCTIONS TO USERS:** This equipment complies with the requirements of FCC (Federal Communication Commission) equipment provided that the following conditions are met. Some cables have to be used with the core set. Use the accessory cable or a designated-type cable for the connection. For cables that have a core only at one end, connect the core to the projector.

**CAUTION:** Changes or modifications not expressly approved by the party responsible for compliance could void the user's authority to operate the equipment.

## For the Customers in CANADA

**NOTICE:** This Class B digital apparatus complies with Canadian ICES-003.

# Warranty And After-Service

Unless seen any abnormal operations (mentioned with the first paragraph of WARNING in this manual), when a problem occurs with the equipment, first refer to the "Troubleshooting" section of the "Operating Guide", and run through the suggested checks. If this does not resolve the problem contact your dealer or service company. They will tell you what warranty condition is applied.

Contents

			
<b>About this manual</b> . . . . .	<b>1</b>	<b>PICTURE menu</b> . . . . .	<b>27</b>
<b>Contents</b> . . . . .	<b>2</b>	BRIGHTNESS, CONTRAST, GAMMA, COLOR TEMP, COLOR, TINT, SHARPNESS, MY MEMORY	
<b>Projector features</b> . . . . .	<b>3</b>	<b>IMAGE menu</b> . . . . .	<b>30</b>
<b>Preparations</b> . . . . .	<b>3</b>	ASPECT, OVER SCAN, V POSITION, H POSITION, H PHASE, H SIZE, AUTO ADJUST EXECUTE	
Contents of package . . . . .	3	<b>INPUT menu</b> . . . . .	<b>32</b>
Fastening the lens cover . . . . .	3	PROGRESSIVE, VIDEO NR, COLOR SPACE, COMPONENT, VIDEO FORMAT, FRAME LOCK, COMPUTER IN, RESOLUTION	
<b>Part names</b> . . . . .	<b>4</b>	<b>SETUP menu</b> . . . . .	<b>35</b>
Projector . . . . .	4	AUTO KEYSTONE  EXECUTE, KEYSTONE  ,	
Control panel . . . . .	5	WHISPER, MIRROR, VOLUME, SPEAKER, AUDIO	
Rear panel . . . . .	5	<b>SCREEN menu</b> . . . . .	<b>38</b>
Remote control . . . . .	6	LANGUAGE, MENU POSITION, BLANK, START UP, MyScreen, MyScreen Lock, MESSAGE, SOURCE NAME	
<b>Setting up</b> . . . . .	<b>7</b>	<b>OPTION menu</b> . . . . .	<b>42</b>
Arrangement . . . . .	7	AUTO SEARCH, AUTO KEYSTONE  ,	
Connecting your devices . . . . .	9	AUTO ON, AUTO OFF, LAMP TIME, FILTER TIME, MY BUTTON, SERVICE, SECURITY	
Using a USB storage . . . . .	12	<b>MIU menu</b> . . . . .	<b>53</b>
Using an SD card . . . . .	12	LIVE MODE, LIVE MODE SETTING, PC-LESS PRESENTATION, SETUP, PROJECTOR NAME, e-SHOT, INFORMATION, SERVICE	
Connecting power supply . . . . .	13	<b>C.C. (closed caption) menu</b> . . . . .	<b>63</b>
Using the security bar and slot . . . . .	13	DISPLAY, MODE, CHANNEL	
<b>Remote control</b> . . . . .	<b>14</b>	<b>Maintenance</b> . . . . .	<b>64</b>
Putting batteries . . . . .	14	Replacing the lamp . . . . .	64
About the remote control signal . . . . .	14	Cleaning and replacing the air filter . . . . .	66
Changing the frequency of remote control signal . . . . .	15	Replacing the internal clock battery . . . . .	68
Using as a simple PC mouse & keyboard . . . . .	15	Other care . . . . .	69
<b>Power on/off</b> . . . . .	<b>16</b>	<b>Troubleshooting</b> . . . . .	<b>70</b>
Turning on the power . . . . .	16	Related messages . . . . .	70
Turning off the power . . . . .	16	Regarding the indicator lamps . . . . .	71
<b>Operating</b> . . . . .	<b>17</b>	Shutting the projector down . . . . .	72
Adjusting the volume . . . . .	17	Resetting all settings . . . . .	72
Temporarily muting the sound . . . . .	17	Phenomena that may be easy to be mistaken for machine defects . . . . .	73
Selecting an input signal . . . . .	17	<b>Specifications</b> . . . . .	<b>76</b>
Searching an input signal . . . . .	18		
Selecting an aspect ratio . . . . .	18		
Adjusting the projector's elevator . . . . .	19		
Adjusting the zoom and focus . . . . .	19		
Using the automatic adjustment feature . . . . .	20		
Adjusting the position . . . . .	20		
Correcting the keystone distortions . . . . .	21		
Using the magnify feature . . . . .	21		
Freezing the screen . . . . .	22		
Temporarily blanking the screen . . . . .	22		
Using the menu function . . . . .	23		
<b>EASY MENU</b> . . . . .	<b>25</b>		
ASPECT, AUTO KEYSTONE  EXECUTE, KEYSTONE  , PICTURE MODE, BRIGHTNESS, CONTRAST, COLOR, TINT, SHARPNESS, WHISPER, MIRROR, RESET, FILTER TIME, LANGUAGE, Go to Advanced Menu...			

## Projector features

This product realizes the large projection image of various image signals, even if in a small space. This product also can offer you convenience and various uses by the following features.

- ✓ It is possible to project the images from an SD memory card or USB memory by the PC-LESS Presentation function of this projector.
- ✓ This projector can be controlled and monitored via LAN connection.
- ✓ Using the designated wireless network card realizes wireless LAN connection.

## Preparations

### Contents of package

Please see the “Contents of package” section in the User’s Manual (concise) which is a book. Your projector should come with the items shown there. Contact immediately your dealer if anything is missing.

**NOTE** • Keep the original packing materials, for future reshipment. Be sure to use the original packing materials when moving the projector. Use special caution for the lens.

### Fastening the lens cover

To avoid losing the lens cover, please fasten the lens cover to the projector using the enclosed strap.

1. Fix the strap to the strap hole of the lens cover. Thread one end of the strap through the strap hole of the lens cover and make the loop at the end, and let the other end of the strap through the loop. Not have a knot in the strap at either end.
2. Fix the strap to the strap hole of the projector. Thread the other end of the strap through the strap hole of the projector and make the loop there. Let the lens cover with the one end of strap through the loop.

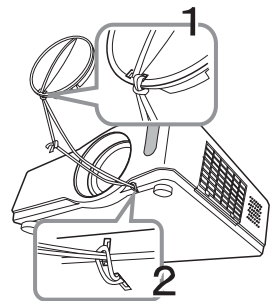

Part names

**Projector**

- (1) Lamp cover (📖64).  
The lamp unit is inside.
- (2) Focus ring (📖19)
- (3) Zoom ring (📖19)
- (4) Control panel (📖5)
- (5) Elevator buttons (x 2) (📖19)
- (6) Elevator feet (x 2) (📖19)
- (7) Remote sensor (📖14)
- (8) Lens (📖16, 69)
- (9) Lens cover (📖3)
- (10) Intake vents
- (11) Filter cover (📖66)  
The air filter and intake vent are inside.
- (12) Speaker (📖36)
- (13) Exhaust vent
- (14) AC inlet (📖13)
- (15) Power switch (📖16)
- (16) Rear panel (📖5)
- (17) Security bar (📖13)
- (18) Security slot (📖13)
- (19) SD card slot cover (📖68)  
The internal clock battery is inside.

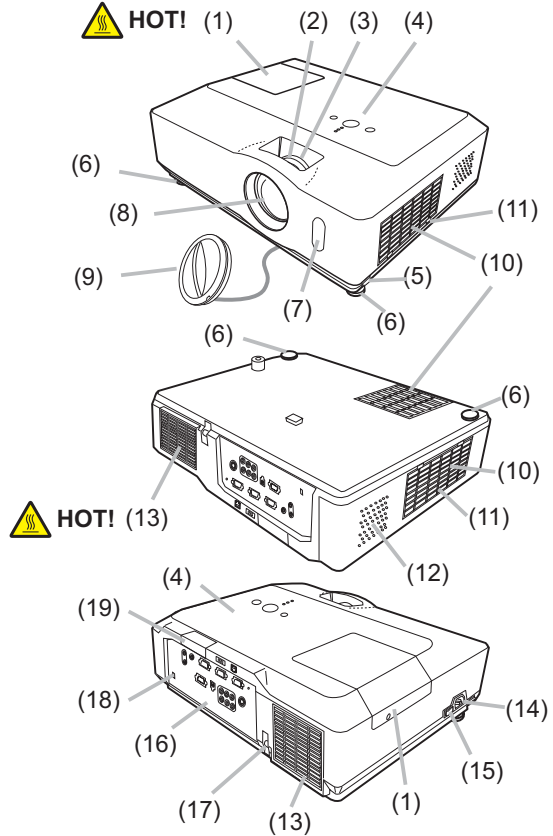

**⚠ WARNING ►HOT!** : Do not touch around the lamp cover and the exhaust vents during use or just after use, since it is too hot.

- Do not look into the lens or vents while the lamp is on, since the strong light is not good for your eyes.
- Do not handle the elevator buttons without holding the projector, since the projector may drop down.

**⚠ CAUTION** ► Maintain normal ventilation to prevent the projector from heating up. Do not cover, block or plug up the vents. Do not place anything that can stick or be sucked to the vents, around the intake vents. Clean the air filter periodically.

- Do not use the security bar and slot to prevent the projector from falling down, since it is not designed for it.

## Control panel

- (1) STANDBY/ON button (📖16)
- (2) INPUT button (📖17, 23)
- (3) MENU button (📖23)  
It consists of four cursor buttons.
- (4) POWER indicator (📖16, 71)
- (5) TEMP indicator (📖71)
- (6) LAMP indicator (📖71)

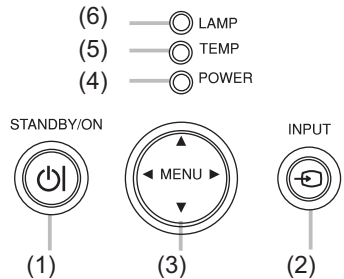

## Rear panel

- (1) AUDIO IN1 port (📖9)
- (2) AUDIO IN2 port (📖9)
- (3) AUDIO OUT port (📖9)
- (4) COMPUTER IN1 port (📖9)
- (5) COMPUTER IN2 port (📖9)
- (6) MONITOR OUT port (📖9)
- (7) Shutdown switch (📖72)
- (8) CONTROL port (📖9)
- (9) USB port (📖9)
- (10) COMPONENT (Y, Cb/Pb, Cr/Pr) ports (📖9)
- (11) VIDEO port (📖9)
- (12) S-VIDEO port (📖9)
- (13) AUDIO IN3 (L,R) ports (📖9)
- (14) LAN port (📖9)
- (15) USB STORAGE port (📖9)
- (16) SD card slot (📖9)

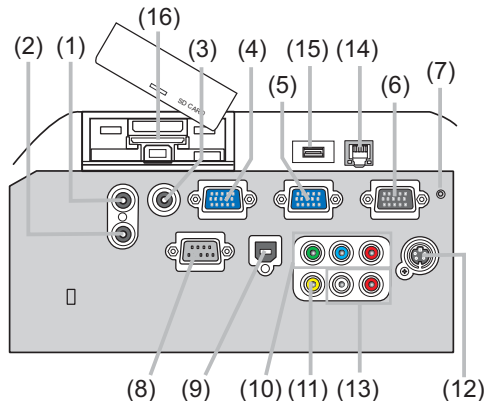

**⚠ CAUTION** ▶ Use the shutdown switch only when the projector is not turned off by normal procedure, since pushing this switch stops operation of the projector without cooling it down.

## Remote control

- (1) VIDEO button (📖18)
- (2) COMPUTER button (📖17)
- (3) SEARCH button (📖18)
- (4) STANDBY/ON button (📖16)
- (5) ASPECT button (📖18)
- (6) AUTO button (📖20)
- (7) BLANK button (📖22)
- (8) MAGNIFY - ON button (📖21)
- (9) MAGNIFY - OFF button (📖15, 21)
- (10) HOME button (📖15)
- (11) END button (📖15)
- (12) PAGE UP button (📖15)
- (13) PAGE DOWN button (📖15)
- (14) VOLUME button (📖17)
- (15) MUTE button (📖15, 17)
- (16) FREEZE button (📖22)
- (17) MY BUTTON - 1 button (📖44)
- (18) MY BUTTON - 2 button (📖44)
- (19) KEYSTONE button (📖21)
- (20) POSITION button (📖20, 23)
- (21) MENU button (📖23)
- (22) ▲/▼/◀/▶ cursor buttons (📖15, 23, 24)
- (23) ENTER button (📖15, 23, 24)
- (24) ESC button (📖15, 23)
- (25) RESET button (📖15, 23, 24)
- (26) Battery cover (📖14)

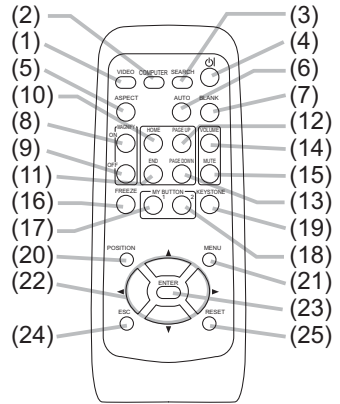

Back of  
the remote control

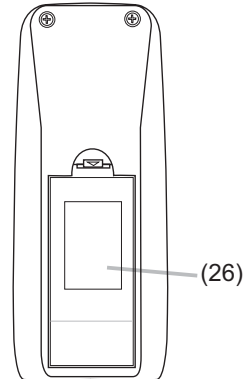

## Setting up

Install the projector according to the environment and manner the projector will be used in.

### Arrangement

Refer to the illustrations and tables below to determine screen size and projection distance.

The values shown in the table are calculated for a full size screen: 1024×768

- Ⓐ Screen size (diagonal)
- Ⓑ Projection distance (±10%)
- Ⓒ<sub>1</sub>, Ⓒ<sub>2</sub> Screen height (±10%)

#### On a horizontal surface

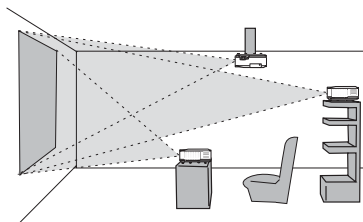
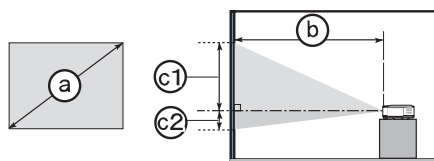

#### Suspended from the ceiling

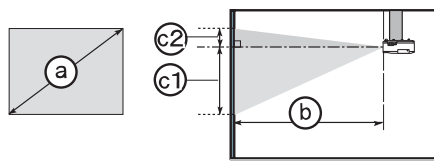

- Keep a space of 30 cm or more between the sides of the projector and other objects such as walls.
- Consult with your dealer before a special installation such as suspending from a ceiling.

Ⓐ Screen size (diagonal)		4 : 3 screen								16 : 9 screen							
		Ⓑ Projection distance				Ⓒ <sub>1</sub> Screen height		Ⓒ <sub>2</sub> Screen height		Ⓑ Projection distance				Ⓒ <sub>1</sub> Screen height		Ⓒ <sub>2</sub> Screen height	
		min.		max.						min.		max.					
inch	m	m	inch	m	inch	cm	inch	cm	inch	m	inch	m	inch	cm	inch	cm	inch
30	0.8	0.9	35	1.1	43	41	16	5	2	1.0	39	1.2	47	39	15	-1	0
40	1.0	1.2	47	1.4	57	55	22	6	2	1.3	52	1.6	62	51	20	-2	-1
50	1.3	1.5	59	1.8	71	69	27	8	3	1.6	65	2.0	78	64	25	-2	-1
60	1.5	1.8	71	2.2	86	82	32	9	4	2.0	78	2.4	94	77	30	-2	-1
70	1.8	2.1	83	2.5	100	96	38	11	4	2.3	91	2.8	109	90	35	-3	-1
80	2.0	2.4	95	2.9	115	110	43	12	5	2.6	104	3.2	125	103	41	-3	-1
90	2.3	2.7	107	3.3	129	123	49	14	5	3.0	117	3.6	141	116	46	-4	-1
100	2.5	3.0	119	3.6	144	137	54	15	6	3.3	130	4.0	156	129	51	-4	-2
120	3.0	3.6	143	4.4	172	165	65	18	7	4.0	156	4.8	188	154	61	-5	-2
150	3.8	4.6	179	5.5	216	206	81	23	9	4.9	195	6.0	235	193	76	-6	-2
200	5.1	6.1	239	7.3	288	274	108	30	12	6.6	261	8.0	314	257	101	-8	-3
250	6.4	7.6	299	9.1	360	343	135	38	15	8.3	326	10.0	392	322	127	-10	-4
300	7.6	9.1	359	11.0	432	411	162	46	18	9.9	391	12.0	471	386	152	-12	-5



**Arrangement (continued)**

**⚠ WARNING** ► Place the projector in a stable horizontal position. If the projector falls or is knocked over it could cause injury and/or damage to the projector. Using a damaged projector could then result in fire and/or electric shock.

- Do not place the projector on an unstable, slanted or vibrational surface such as a wobbly or inclined stand.
- Do not place the projector on its side, front or rear position.
- Consult with your dealer before a special installation such as suspending from a ceiling.

► Place the projector in a cool place, and ensure that there is sufficient ventilation. The high temperature of the projector could cause fire, burns and/or malfunction of the projector.

- Do not stop-up, block or otherwise cover the projector's vents.
- Keep a space of 30 cm or more between the sides of the projector and other objects such as walls.
- Do not place the projector on metallic thing or anything weak in heat.
- Do not place the projector on carpet, cushions or bedding.
- Do not place the projector in direct sunlight or near hot objects such as heaters.
- Do not anything near the projector lens or vents, or on top of the projector.
- Do not place anything that may be sucked into or stick to the vents on the bottom of the projector. This projector has some intake vents also on the bottom.
- Do not place the projector anyplace where it may get wet. Getting the projector wet or inserting liquid into the projector could cause fire, electric shock and/or malfunction of the projector.
- Do not place the projector in a bathroom or the outdoors.
- Do not place anything containing liquid near the projector.

**⚠ CAUTION** ► Avoid placing the projector in smoky, humid or dusty place. Placing the projector in such places could cause fire, electric shock and/or malfunction of the projector.

- Do not place the projector near humidifiers, smoking spaces or a kitchen.
- Position the projector to prevent light from directly hitting the projector's remote sensor.

## Connecting your devices

Be sure to read the manuals for devices before connecting them to the projector. Make sure that all the devices are suitable to be connected with this product, and prepare the cables required to connect. Please refer to the following illustrations to connect them.

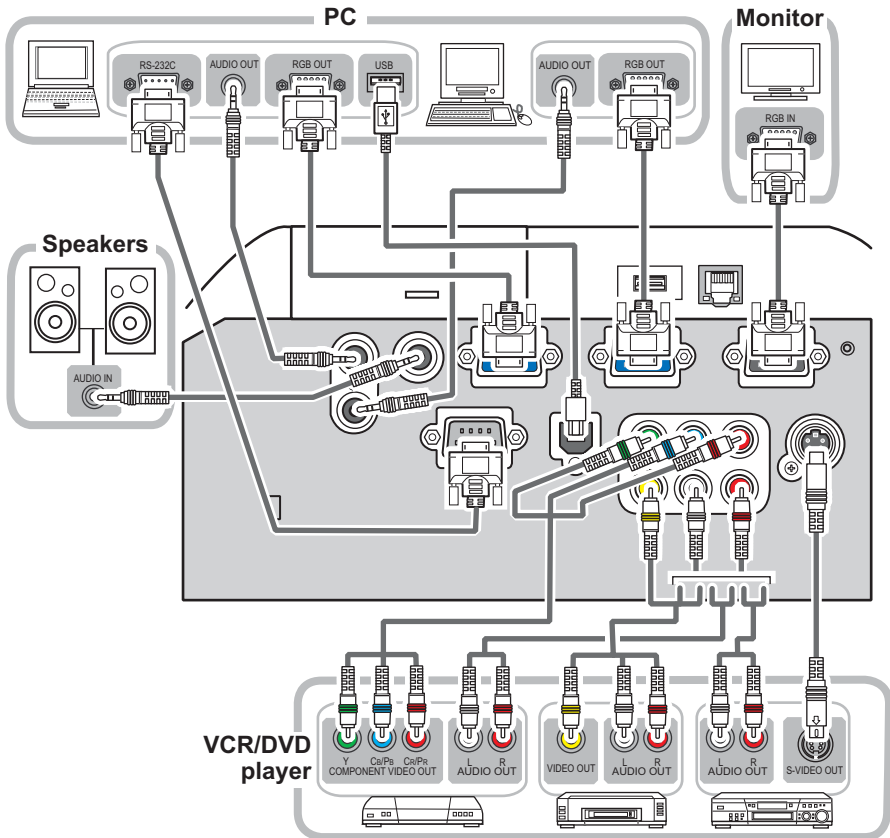

(continued on next page)

## Connecting your devices (continued)

To use MIU (Multi Information processing Unit) function, please connect at least one of the devices drawn in the following illustration to the projector.

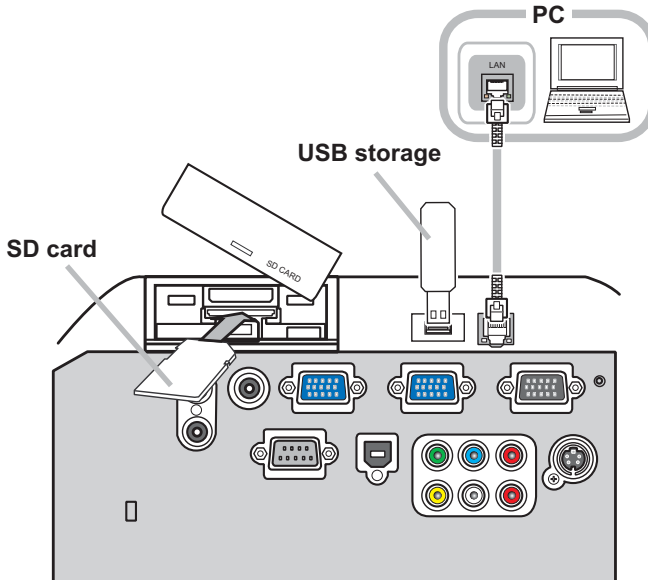

**⚠ WARNING** ▶ Do not disassemble or modify the projector and accessories.

▶ Be careful not to damage the cables, and do not use damaged cables.

**⚠ CAUTION** ▶ Turn off all devices and unplug their power cords prior to connecting them to projector. Connecting a live device to the projector may generate extremely loud noises or other abnormalities that may result in malfunction or damage to the device and the projector.

▶ Use appropriate accessory or designated cables. Ask your dealer about non-accessory cables which may be required a specific length or a ferrite core by the regulations. For cables with a core only at one end, connect the end with the core to the projector.

▶ Make sure that devices are connected to the correct ports. An incorrect connection may result in malfunction or damage to the device and the projector.

(continued on next page)

## Connecting your devices (continued)

**NOTE** • Be sure to read the manuals for devices before connecting them to the projector, and make sure that all the devices are suitable to be connected with this product. Before connecting to a PC, check the signal level, the signal timing, and the resolution.

- Be sure to consult to the administrator of the network. Do not connect LAN port to any network that might have the excessive voltage.
- Some signal may need an adapter to input this projector.
- Some PCs have multiple screen display modes that may include some signals which are not supported by this projector.
- Although the projector can display signals with resolution up to UXGA (1600X1200), the signal will be converted to the projector's panel resolution before being displayed. The best display performance will be achieved if the resolutions of the input signal and the projector panel are identical.
- While connecting, make sure that the shape of the cable's connector fits the port to connect with. And be sure to tighten the screws on connectors with screws.
- When connecting a laptop PC to the projector, be sure to activate the PC's external RGB output. (Set the laptop PC to CRT display or to simultaneous LCD and CRT display.) For details on how this is done, please refer to the instruction manual of the corresponding laptop PC.
- When the picture resolution is changed on a PC depending on an input, automatic adjustment function may take some time and may not be completed. In this case, you may not be able to see a check box to select "Yes/No" for the new resolution on Windows. Then the resolution will go back to the original. It might be recommended to use other CRT or LCD monitors to change the resolution.
- In some cases, this projector may not display a proper picture or display any picture on screen. For example, automatic adjustment may not function correctly with some input signals. An input signal of composite sync or sync on G may confuse this projector, so the projector may not display a proper picture.

### About Plug-and-Play capability

Plug-and-Play is a system composed of a PC, its operating system and peripheral equipment (i.e. display devices). This projector is VESA DDC 2B compatible. Plug-and-Play can be used by connecting this projector to a PC that is VESA DDC (display data channel) compatible.

- Take advantage of this feature by connecting an RGB cable to the COMPUTER IN1 port (DDC 2B compatible). Plug-and-Play may not work properly if any other type of connection is attempted.
- Please use the standard drivers in your PC as this projector is a Plug-and-Play monitor.

## Connecting your devices (continued)

### Using a USB storage

In order to view images stored in a USB storage, such as a USB memory, insert the device into the USB STORAGE slot.

Before removing the USB storage, be sure to perform the REMOVE MEDIA procedure using the PC-LESS PRESENTATION menu under the MIU menu.

### Using an SD card

In order to view images stored in an SD storage, such as an SD memory card, insert the device into the SD card slot. Or, in order to use the wireless network function, load the internal clock battery (☒ 68) and insert the designated wireless network card into the SD card slot.

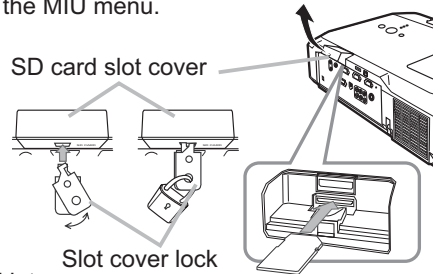

#### Inserting the SD card

1. Make sure that the power code is not plugged into the projector for the wireless network card only.
2. Remove the SD card slot cover. To remove it, it might be recommended to hook the edge of its side face upward.
3. Slowly insert the SD card completely into the SD card slot. Make sure that the angled corner of the SD card is placed into the right side of the SD card slot, while inserting.
4. Replace the SD card slot cover. It is recommended that the cover is slid sideways to the projector.

#### Using the slot cover lock for security

Using the enclosed slot cover lock can prevent the SD card slot cover from being opened.

1. Open the two plates of the slot cover lock to put the tips of two plates together, and then insert the tips to the lock hole of the SD card slot cover.
2. Put the body of the two plates together. Then, hook a padlock or combination lock to the hole of the slot cover lock.

#### Removing the SD card

1. Perform the REMOVE MEDIA procedure using the PC-LESS PRESENTATION menu under the MIU menu for SD Storage card only.
2. Turn the projector off and unplug the power code from the projector for the wireless network card only.
3. Remove the SD card slot cover. After taking the SD card away, replace the SD card slot cover.

**⚠ WARNING** ▶ Do not disassemble or modify the projector and accessories.  
▶ Do not touch the SD card while being accessed.

**⚠ CAUTION** ▶ The designated wireless network card is required to use the wireless network function of this projector.

▶ The wireless network card is not permitted to be sold or used in some countries and regions. Use the card only in the country or region where you buy it. For more information, contact to your dealer.

**NOTE** • When using the projector with a wired LAN, please remove the wireless network card.

## Connecting power supply

At first, make sure that the power switch of the projector is set to OFF position (marked "O").

1. Put the connector of the power cord into the AC inlet of the projector.
2. Firmly plug the power cord's plug into the outlet.

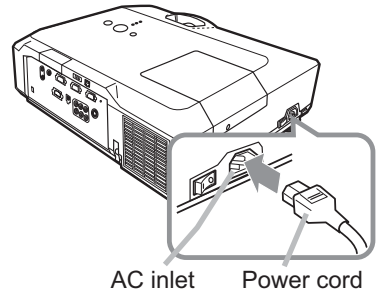

**⚠ WARNING** ▶ Please use extra caution when connecting the power cord, as incorrect or faulty connections may result in fire and/or electrical shock.

- Only use the power cord that came with the projector. If it is damaged, contact your dealer to newly get correct one.
- Only plug the power cord into an outlet whose voltage is matched to the power cord. The power outlet should be close to the projector and easily accessible. Remove the power cord for complete separation.
- Never modify the power cord.

## Using the security bar and slot

A commercial anti-theft chain or wire up to 10 mm in diameter can be attached to the security bar on the projector.

Also this product has the security slot for the Kensington lock.

For details, see the manual of the security tool.

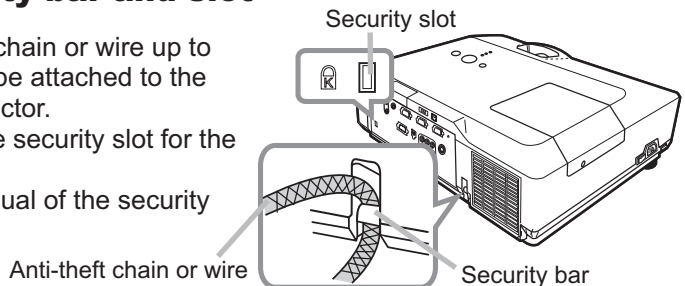

**⚠ WARNING** ▶ Do not use the security bar and slot to prevent the projector from falling down, since it is not designed for it.

**⚠ CAUTION** ▶ Do not place anti-theft chain or wire near the exhaust vents. It may become too hot.

**NOTE** • The security bar and slot is not comprehensive theft prevention measures. It is intended to be used as supplemental theft prevention measure.

## Remote control

**Putting batteries**

Please set the batteries to the remote control before using it. If the remote control starts to malfunction, try to replace the batteries. If you will not use the remote control for long period, remove the batteries from the remote control and store them in a safe place.

1. Holding the hook part of the battery cover, remove it.
2. Align and insert the two AA batteries (**HITACHI MAXELL, Part No. LR6 or R6P**) according to their plus and minus terminals as indicated in the remote control.
3. Replace the battery cover in the direction of the arrow and snap it back into place.

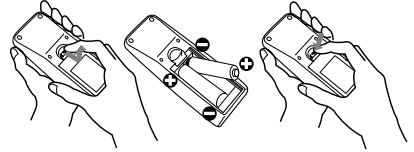

**⚠ WARNING** ▶ Always handle the batteries with care and use them only as directed. Improper use may result in battery explosion, cracking or leakage, which could result in fire, injury and/or pollution of the surrounding environment.

- Be sure to use only the batteries specified. Do not use batteries of different types at the same time. Do not mix a new battery with used one.
- Make sure the plus and minus terminals are correctly aligned when loading a battery.
- Keep a battery away from children and pets.
- Do not recharge, short circuit, solder or disassemble a battery.
- Do not allow a battery in a fire or water. Keep batteries in a dark, cool and dry place.
- If you observe battery leakage, wipe out the leakage and then replace a battery. If the leakage adheres to your body or clothes, rinse well with water immediately.
- Obey the local laws on disposing the battery.

**About the remote control signal**

The remote control works with the projector's remote sensor. This projector has a remote sensor on the front. The sensor senses the signal within the following range when the sensor is active:

60 degrees (30 degrees to the left and right of the sensor) within 3 meters about.

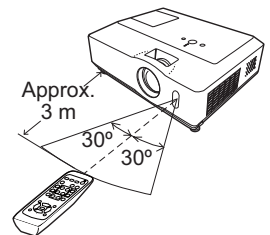

**NOTE** • The remote control signal reflected in the screen or the like may be available. If it is difficult to send the signal to the sensor directly, attempt to make the signal reflect.

- The remote control uses infrared light to send signals to the projector (Class 1 LED), so be sure to use the remote control in an area free from obstacles that could block the remote control's signal to the projector.
- The remote control may not work correctly if strong light (such as direct sun light) or light from an extremely close range (such as from an inverter fluorescent lamp) shines on the remote sensor of the projector. Adjust the position of projector avoiding those lights.

## Changing the frequency of remote control signal

The accessory remote control has the two choices on signal frequency Mode 1:NORMAL and Mode 2:HIGH. If the remote control does not function properly, attempt to change the signal frequency. In order to set the Mode, please keep pressing the combination of two buttons listed below simultaneously for about 3 seconds.

- (1) Set to Mode 1:NORMAL... MUTE and RESET buttons
- (2) Set to Mode 2:HIGH... MAGNIFY OFF and ESC buttons

Please remember that the REMOTE FREQ. in the SERVICE item of the OPTION menu (46) of the projector to be controlled should be set to the same mode as the remote control.

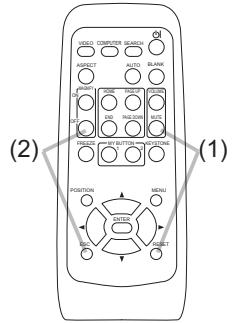

## Using as a simple PC mouse & keyboard

The accessory remote control works as a simple mouse and keyboard of the PC, when the projector's USB port (B type) connects with the PC's USB port (A type) port via a mouse cable.

- (1) **HOME key:** Press HOME button.
- (2) **END key:** Press END button.
- (3) **PAGE UP key:** Press PAGE UP button.
- (4) **PAGE DOWN key:** Press PAGE DOWN button.
- (5) **Mouse left button:** Press ENTER button.
- (6) **Move pointer:** Use the cursor buttons ▲, ▼, ◀ and ▶.
- (7) **ESC key:** Press ESC button.
- (8) **Mouse right button:** Press RESET button.

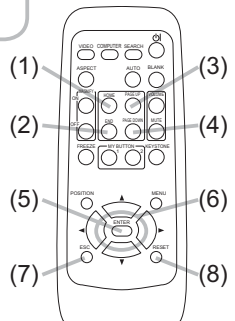
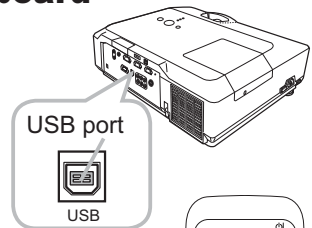

**⚠ WARNING** ▶ Improper use of the simple mouse & keyboard function could damage your equipment. While using this function, please connect this product only to a PC. Be sure to check your PC's manuals before connecting this product to the PC.

- NOTE** • When the simple mouse & keyboard function of this product does not work correctly, please check the following.
- When a USB cable connects this projector with a PC having a built-in pointing device (e.g. track ball) like a notebook PC, open BIOS setup menu, then select the external mouse and disable the built-in pointing device, because the built-in pointing device may have priority to this function.
  - Windows 95 OSR 2.1 or higher is required for this function. And also this function may not work depending on the PC's configurations and mouse drivers.
  - You cannot do things like press two buttons at once (for instance, pressing two buttons at the same time to move the mouse pointer diagonally).
  - This function is activated only when the projector is working properly. This function is not available while the lamp is warming up (the POWER indicator blinks green), and while adjusting the volume and display, correcting for keystone, zooming in on the screen, using the BLANK function, or displaying the menu screen.



## Power on/off

## Turning on the power

1. Make sure that the power cord is firmly and correctly connected to the projector and the outlet.
2. Remove the lens cover, and set the power switch to ON position (marked "I").  
The POWER indicator will light up in steady orange (📖71). Then wait several seconds because the buttons may not function for these several seconds.
3. Press STANDBY/ON button on the projector or the remote control.  
The projection lamp will light up and POWER indicator will begin blinking in green. When the power is completely on, the indicator will stop blinking and light in steady green (📖71).

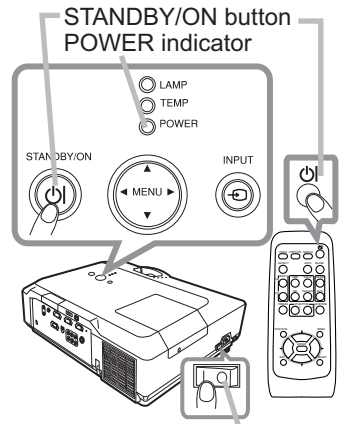

To display the picture, select an input signal according to the section "Selecting an input signal" (📖17).

## Turning off the power

1. Press the STANDBY/ON button on the projector or the remote control. The message "Power off?" will appear on the screen for about 5 seconds.
2. Press the STANDBY/ON button again while the message appears.  
The projector lamp will go off, and the POWER indicator will begin blinking in orange. Then POWER indicator will stop blinking and light in steady orange when the lamp cooling is complete (📖71).
3. Make sure that POWER indicator lights in steady orange, and set the power switch to OFF position (marked "O").  
POWER indicator will go off. Attach the lens cover.

Do not turn the projector on for about 10 minutes or more after turning it off. Turning the projector on again too soon could shorten the lifetime of some consumable parts of the projector.



Power switch

**⚠ WARNING** ▶ A strong light is emitted when the projector's power is on. Do not look into the lens of the projector or look inside of the projector through any of the projector's openings.  
▶ Do not touch around the lamp cover and the exhaust vents during use or just after use, since it is too hot.

**NOTE** • Turn the power on/off in right order. Please power on the projector prior to the connected devices.  
• When the AUTO ON of the OPTION menu is set to the TURN ON, and the power was turned off by the power switch last time, turning the power switch on makes the projection lamp light on without pushing the STANDBY/ON button (📖42).  
• Use the shutdown switch (📖72) only when the projector is not turned off by normal procedure.

Operating

### Adjusting the volume

1. Press VOLUME button on the remote control.  
A dialog will appear on the screen to aid you in adjusting the volume.
2. Use the ▲/▼ cursor buttons to adjust the volume.  
To close the dialog and complete the operation, press the VOLUME button again. Even if you do not do anything, the dialog will automatically disappear after a few seconds.
  - When  $\times$  is selected for current picture input port, the volume adjustment is disable. Please see AUDIO item of SETUP menu ( [63](#) ).

VOLUME button

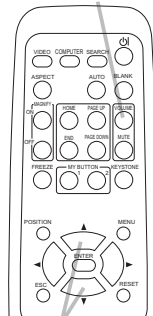

▲/▼ button

### Temporarily muting the sound

1. Press MUTE button on the remote control.  
A dialog will appear on the screen indicating that you have muted the sound. To restore the sound, press the MUTE or VOLUME button. Even if you do not do anything, the dialog will automatically disappear after a few seconds.
  - When  $\times$  is selected for current picture input port, the sound is always muted. Please see AUDIO item of SETUP menu ( [63](#) ).
  - When  $\times$  is selected to VIDEO or S-VIDEO port, the C.C. (Closed Caption) is automatically activated if the C.C. is set to AUTO in the DISPLAY of the C.C. menu and the input signal from the port supports the C.C. feature ( [63](#) ).

MUTE button

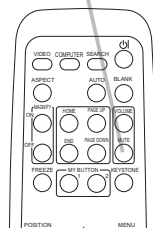

### Selecting an input signal

1. Press INPUT button on the projector.  
Each time you press the button, the projector switches its input port from the current port as below.



- While TURN ON is selected for AUTO SEARCH item in OPTION menu ( [42](#) ), the projector will keep checking the ports in above order repeatedly till an input signal is detected.

1. Press COMPUTER button on the remote control.  
Each time you press the button, the projector switches its input port from the current port as below.



- While TURN ON is selected for AUTO SEARCH item in OPTION menu, the projector will keep checking every port sequentially till an input signal is detected ( [42](#) ). If COMPUTER button is pushed when VIDEO, S-VIDEO or COMPONENT port is selected, the projector will check COMPUTER IN1 port first.

INPUT button

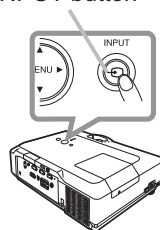

COMPUTER button

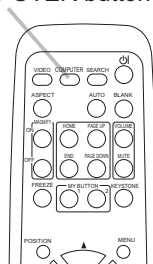

(continued on next page)

### Selecting an input signal (continued)

VIDEO button

1. Press VIDEO button on the remote control.
  - Each time you press the button, the projector switches its input port from the current port as below.

COMPONENT (Y, Cb/Pb, Cr/Pr) → S-VIDEO → VIDEO



- While TURN ON is selected for AUTO SEARCH item in OPTION menu, the projector will keep checking every port sequentially till an input signal is detected (42). If VIDEO button is pushed when COMPUTER IN1, COMPUTER IN2 or MIU port is selected, the projector will check COMPONENT port first.

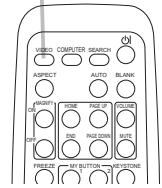

### Searching an input signal

SEARCH button

1. Press SEARCH button on the remote control.
  - The projector will start to check its input ports as below in order to find any input signals.

When an input is found, the projector will stop searching and display the image. If no signal is found, the projector will return to the state selected before the operation.



- While TURN ON is selected for AUTO SEARCH item in OPTION menu (42), the projector will keep checking the ports in above order repeatedly till an input signal is detected.
- The MIU input is skipped, as long as no image is sent from PC on the “Live Mode” of MIU (53).

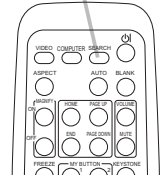

### Selecting an aspect ratio

ASPECT button

1. Press ASPECT button on the remote control.
  - Each time you press the button, the projector switches the mode for aspect ratio in turn.

- For a computer signal or MIU signal

NORMAL → 4:3 → 16:9 → SMALL



- For a video signal, s-video signal or component video signal

4:3 → 16:9 → 14:9 → SMALL



- For no signal

4:3 (fixed)

- ASPECT button does not work when no proper signal is inputted.
- NORMAL mode keeps the original aspect ratio setting.

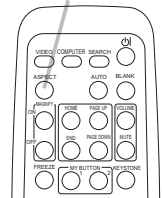

## Adjusting the projector's elevator

When the place to put the projector is slightly uneven to the left or right, use the elevator feet to place the projector horizontally.

Using the feet can also tilt the projector in order to project at a suitable angle to the screen, elevating the front side of the projector within 10 degrees.

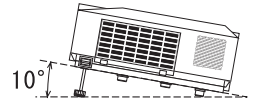

This projector has 2 elevator feet and 2 elevator buttons. An elevator foot is adjustable while pushing the elevator button on the same side as it.

1. Holding the projector, push the elevator buttons to loose the elevator feet.
2. Position the front side of the projector to the desired height.
3. Release the elevator buttons in order to lock the elevator feet.
4. After making sure that the elevator feet are locked, put the projector gently.
5. If necessary, the elevator feet can be manually twisted to make more precise adjustments. Hold the projector when twisting the feet.

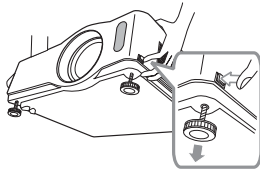

To loose an elevator foot, push the elevator button on the same side as it.

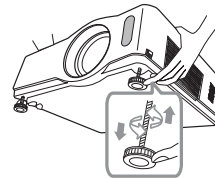

To finely adjust, twist the foot.

**⚠ CAUTION** ► Do not handle the elevator buttons without holding the projector, since the projector may drop down.

► Do not tilt the projector other than elevating its front within 10 degrees using the adjuster feet. A tilt of the projector exceeding the restriction could cause malfunction or shortening the lifetime of consumables, or the projector itself.

## Adjusting the zoom and focus

1. Use the zoom ring to adjust the screen size.
2. Use the focus ring to focus the picture.

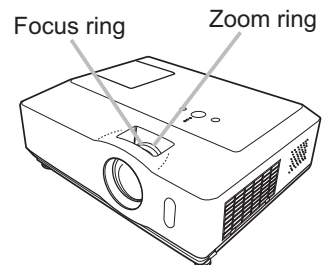

## Using the automatic adjustment feature

1. Press AUTO button on the remote control.  
Pressing this button performs the following.

AUTO button

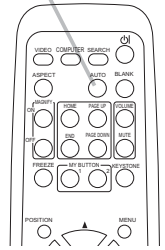

- **For a computer signal or MIU signal**

The vertical position, the horizontal position and the horizontal phase will be automatically adjusted. Make sure that the application window is set to its maximum size prior to attempting to use this feature. A dark picture may still be incorrectly adjusted. Use a bright picture when adjusting.

- **For a video signal and s-video signal**

The video format best suited for the respective input signal will be selected automatically. This function is available only when the AUTO is selected for the VIDEO FORMAT item in the INPUT menu (☞ 33). The vertical position and horizontal position will be automatically set to the default.

- **For a component video signal**

The vertical position, horizontal position and horizontal phase will be automatically set to the default.

- The automatic adjustment operation requires approx. 10 seconds. Also please note that it may not function correctly with some input. When this function is performed for a video signal, a certain extra such as a line may appear outside a picture.
- The items adjusted by this function may vary when the FINE or DISABLE is selected for the AUTO ADJUST item of the SERVICE item in the OPTION menu (☞ 45).

## Adjusting the position

1. Press POSITION button on the remote control when no menu is indicated.  
The "POSITION" indication will appear on the screen.

2. Use the ▲/▼/◀/▶ cursor buttons to adjust the picture position.

When you want to reset the operation, press RESET button on the remote control during the operation. To complete this operation, press POSITION button again. Even if you do not do anything, the dialog will automatically disappear after a few seconds.

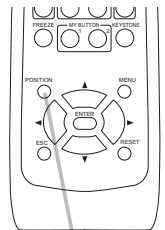

POSITION button

- When this function is performed on a video signal, s-video signal or component video signal, some image such as an extra-line may appear at outside of the picture.
- If POSITION button is pressed when a menu is indicated on screen, the displayed picture does not move its position but the menu does.

## Correcting the keystone distortions

KEYSTONE button

1. Press KEYSTONE button on the remote control. A dialog will appear on the screen to aid you in correcting the distortion.
2. Use the ▲/▼ cursor buttons to select AUTO or MANUAL operation, and press the ► button to perform the following.

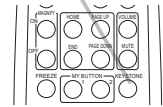
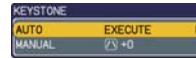

- (1) AUTO executes automatic vertical keystone correction.
- (2) MANUAL displays a dialog for keystone correction.  
Use the ▲/▼ buttons for adjustment.



To close the dialog and complete this operation, press KEYSTONE button again. Even if you do not do anything, the dialog will automatically disappear after a few seconds.

- The adjustable range of this correction will vary among inputs. For some input, this function may not work well.
- When V:INVERT or H&V:INVERT is selected to the MIRROR item in the SETUP menu, if the projector screen is inclined or angled downward, this function may not work correctly.
- When the zoom adjustment is set to the TELE (telephoto focus), the automatic keystone distortion correction may be excessive. This function should be used when the zoom adjustment is set to the full WIDE (wide-angle focus) whenever possible.
- When the projector is placed on the level (about  $\pm 3^\circ$ ), the automatic keystone distortion correction may not work.
- When the projector is inclined to near  $\pm 30$  degree or over, this function may not work well.
- This function will be unavailable when Transition Detector is on (M51).

## Using the magnify feature

MAGNIFY ON/OFF button

1. Press the ON button of MAGNIFY on the remote control. The "MAGNIFY" indication will appear on the screen and the projector will go into the MAGNIFY mode. When the ON button of MAGNIFY is pressed first after the projector is started, the picture will be zoomed twice. The indication will disappear in several seconds with no operation.
2. Use the ▲/▼ cursor buttons to adjust the zoom level. The picture of video, s-video or component video signal can be zoomed in up to 2 times, and the one of computer signal can be zoomed in up to 4 times. To move the zoom area, press the POSITION button in the MAGNIFY mode, then use the ▲/▼/◀/▶ cursor buttons to move the area. And to finalize the zoom area, press the POSITION button again.  
To exit from the MAGNIFY mode and restore the screen to normal, press the OFF button of MAGNIFY on the remote control.

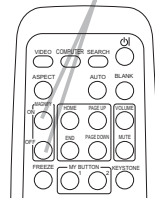

- The projector automatically exits from the MAGNIFY mode when the input signal is changed or when the display condition is changed.
- In the MAGNIFY mode, the keystone distortion condition may vary, it will be restored when the projector exits from the MAGNIFY mode.

**NOTE** • The zoom level can be finely adjusted. Closely watch the screen to find the level you want.

## Freezing the screen

1. Press the FREEZE button on the remote control.  
 The "FREEZE" indication will appear on the screen (however, the indication will not appear when the TURN OFF is selected for the MESSAGE item in the SCREEN menu (☞41)), and the projector will go into the FREEZE mode, which the picture is frozen.  
 To exit the FREEZE mode and restore the screen to normal, press the FREEZE button again.

FREEZE button

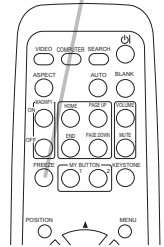

- The projector automatically exits from the FREEZE mode when one of the projector's buttons or remote control buttons of STANDBY/ON, SEARCH, COMPUTER, VIDEO, BLANK, AUTO, VOLUME, MUTE, KEYSTONE, MENU, MAGNIFY and MY BUTTON1/2 (except MY MEMORY or PICTURE MODE is assigned to) (☞44) is pressed.
- If the projector continues projecting a still image for a long time, the LCD panel might possibly be burned in. Do not leave the projector in the FREEZE mode for too long.

## Temporarily blanking the screen

1. Press BLANK button on the remote control.  
 The BLANK screen will be displayed instead of the screen of input signal. Please refer to BLANK item in SCREEN menu (☞38).  
 To exit from the BLANK screen and return to the input signal screen, press BLANK button again.

BLANK button

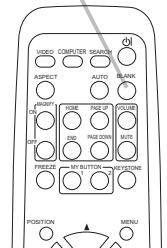

- The projector automatically returns to the input signal screen when one of the projector's buttons or the remote control buttons (except ASPECT, POSITION, MAGNIFY or FREEZE button, also except MY BUTTON1/2 if AUTO KEYSTONE ☞ or MY MEMORY or PICTURE MODE is assigned to (☞44)) is pressed.

**NOTE** • The sound is not connected with the BLANK screen function.  
 If necessary, set the volume or mute first.

## Using the menu function

This projector has the following menus:

PICTURE, IMAGE, INPUT, SETUP, SCREEN, OPTION, MIU, C.C. and EASY MENU.

EASY MENU consists of functions often used, and the other menus are classified into each purpose and brought together as the Advanced Menu.

Each of these menus is operated using the same methods. The basic operations of these menus are as follows.

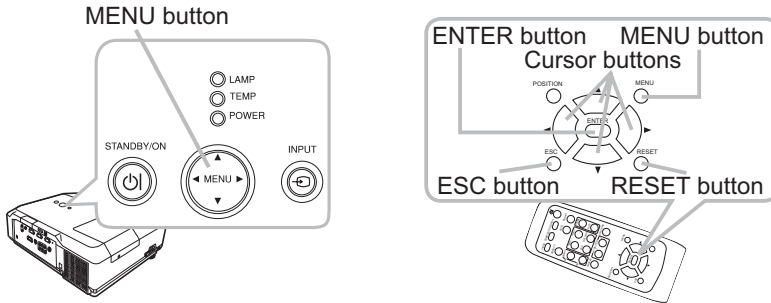

1. Press the MENU button on the remote control or the projector.  
The Advanced Menu or EASY MENU, which has priority just after powered on will appear.  
If you want to move the menu position, use the cursor buttons after pressing the POSITION button. While the projector is displaying any menu, the MENU button on the projector works as the cursor buttons.

### In the EASY MENU

2. If you want to change it to the Advanced Menu, select the Go to Advanced Menu...
3. Use the ▲/▼ cursor buttons to select an item to operate.
4. Use the ◀/▶ cursor buttons to operate the item.



EASY MENU

(continued on next page)



## Using the menu function (continued)

### In the Advanced Menu

2. Use the ▲/▼ cursor buttons to select a menu. If you want to change it to the EASY MENU, select EASY MENU. Then press the ► cursor button, or ENTER button to select an item. The lower layer menu of the selected item will appear.



Advanced Menu

3. Use the ▲/▼ cursor buttons to select an item to operate. Then press the ► cursor button, or ENTER button to progress. The operation menu of the selected item will appear.
4. Use the ▲/▼ cursor buttons to operate the item.
  - Some functions cannot be performed when a certain input port is selected, or when a certain input signal is displayed.
  - When you want to reset the operation, press RESET button on the remote control during the operation. Note that some items (ex. LANGUAGE, H PHASE, VOLUME) cannot be reset.
  - In the Advanced Menu, when you want to return to the previous display, press the ◀ cursor button or ESC button on the remote control.
5. Press MENU button on the remote control again to close the menu and complete this operation. Even if you do not do anything, the dialog will automatically disappear after about 10 seconds.

## EASY MENU

From the EASY MENU, items shown in the table below can be performed.

Select an item using the ▲/▼ cursor buttons. Then perform it according to the following table.



Item	Description																								
<b>ASPECT</b>	Using the ◀/▶ buttons switches the mode for aspect ratio. See the ASPECT item in IMAGE menu (📖30).																								
<b>AUTO KEYSTONE EXECUTE</b> [↵]	Using the ▶ button executes the auto keystone function. See AUTO KEYSTONE [↵] EXECUTE item in SETUP menu (📖35).																								
<b>KEYSTONE</b> [↵]	Using the ◀/▶ buttons corrects the vertical keystone distortion. See KEYSTONE [↵] item in SETUP menu (📖35).																								
<b>PICTURE MODE</b>	<p>Using the ◀/▶ buttons switches the picture mode. The picture modes are combinations of GAMMA and COLOR TEMP settings. Choose a suitable mode according to the projected source.</p> <p>           ↻ → NORMAL ↔ CINEMA ↔ DYNAMIC ↔ BOARD(BLACK) ↻            ↻ → DAYTIME ↔ WHITEBOARD ↔ BOARD(GREEN) ↻         </p> <table border="1"> <thead> <tr> <th></th> <th>COLOR TEMP</th> <th>GAMMA</th> </tr> </thead> <tbody> <tr> <td>NORMAL</td> <td>#2 MID DEFAULT</td> <td>#1 DEFAULT</td> </tr> <tr> <td>CINEMA</td> <td>#3 LOW DEFAULT</td> <td>#2 DEFAULT</td> </tr> <tr> <td>DYNAMIC</td> <td>#1 HIGH DEFAULT</td> <td>#3 DEFAULT</td> </tr> <tr> <td>BOARD(BLACK)</td> <td>#4 Hi-BRIGHT-1 DEFAULT</td> <td>#4 DEFAULT</td> </tr> <tr> <td>BOARD(GREEN)</td> <td>#5 Hi-BRIGHT-2 DEFAULT</td> <td>#4 DEFAULT</td> </tr> <tr> <td>WHITEBOARD</td> <td>#2 MID DEFAULT</td> <td>#5 DEFAULT</td> </tr> <tr> <td>DAYTIME</td> <td>#6 Hi-BRIGHT-3 DEFAULT</td> <td>#6 DEFAULT</td> </tr> </tbody> </table> <ul style="list-style-type: none"> <li>• When the combination of GAMMA and COLOR TEMP differs from pre-assigned modes above, the display on the menu for the PICTURE MODE is “CUSTOM”. Please refer to GAMMA (📖27) and COLOR TEMP (📖28) items in PICTURE menu.</li> <li>• When this function is performed, a certain extra such as a line may appear.</li> </ul>		COLOR TEMP	GAMMA	NORMAL	#2 MID DEFAULT	#1 DEFAULT	CINEMA	#3 LOW DEFAULT	#2 DEFAULT	DYNAMIC	#1 HIGH DEFAULT	#3 DEFAULT	BOARD(BLACK)	#4 Hi-BRIGHT-1 DEFAULT	#4 DEFAULT	BOARD(GREEN)	#5 Hi-BRIGHT-2 DEFAULT	#4 DEFAULT	WHITEBOARD	#2 MID DEFAULT	#5 DEFAULT	DAYTIME	#6 Hi-BRIGHT-3 DEFAULT	#6 DEFAULT
	COLOR TEMP	GAMMA																							
NORMAL	#2 MID DEFAULT	#1 DEFAULT																							
CINEMA	#3 LOW DEFAULT	#2 DEFAULT																							
DYNAMIC	#1 HIGH DEFAULT	#3 DEFAULT																							
BOARD(BLACK)	#4 Hi-BRIGHT-1 DEFAULT	#4 DEFAULT																							
BOARD(GREEN)	#5 Hi-BRIGHT-2 DEFAULT	#4 DEFAULT																							
WHITEBOARD	#2 MID DEFAULT	#5 DEFAULT																							
DAYTIME	#6 Hi-BRIGHT-3 DEFAULT	#6 DEFAULT																							

(continued on next page)

**EASY MENU (continued)**

Item	Description
<b>BRIGHTNESS</b>	Using the ◀/▶ buttons adjusts the brightness. See BRIGHTNESS item in PICTURE menu (📖27).
<b>CONTRAST</b>	Using the ◀/▶ buttons adjusts the contrast. See CONTRAST item in PICTURE menu (📖27).
<b>COLOR</b>	Using the ◀/▶ buttons adjusts the strength of whole color. See COLOR item in PICTURE menu (📖28).
<b>TINT</b>	Using the ◀/▶ buttons adjusts the tint. See TINT item in PICTURE menu (📖28).
<b>SHARPNESS</b>	Using the ◀/▶ buttons adjusts the sharpness. See SHARPNESS item in PICTURE menu (📖29).
<b>WHISPER</b>	Using the ◀/▶ buttons turns off/on the whisper mode. See WHISPER item in SETUP menu (📖36).
<b>MIRROR</b>	Using the ◀/▶ buttons switches the mode for mirror status. See MIRROR item in SETUP menu (📖36).
<b>RESET</b>	Performing this item resets all of EASY MENU items except FILTER TIME and LANGUAGE. A dialog is displayed for confirmation. Selecting RESET using the ▲ button performs resetting.
<b>FILTER TIME</b>	The usage time of the air filter is shown in the menu. Performing this item resets the filter time which counts usage time of the air filter. A dialog is displayed for confirmation. Selecting RESET using the ▲ button performs resetting. See FILTER TIME item in OPTION menu (📖43).
<b>LANGUAGE</b>	Using the ◀/▶ buttons changes the display language. See LANGUAGE item in SCREEN menu (📖38).
<b>Go to Advanced Menu...</b>	Select Go to Advanced Menu... on the menu, and press the ▶ or ENTER button to use the menu of PICTURE, IMAGE, INPUT, SETUP, SCREEN, OPTION, MIU or C.C..

PICTURE menu

From the PICTURE menu, items shown in the table below can be performed.

Select an item using the ▲/▼ cursor buttons, and press the ► cursor button or ENTER button to execute the item. Then perform it according to the following table.

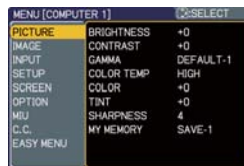

Item	Description
<b>BRIGHTNESS</b>	Using the ▲/▼ buttons adjusts the brightness. Light ⇔ Dark
<b>CONTRAST</b>	Using the ▲/▼ buttons adjusts the contrast. Strong ⇔ Weak
<b>GAMMA</b>	<p>Using the ▲/▼ buttons switches the gamma mode.</p> <p>#1 DEFAULT ⇔ #1 CUSTOM ⇔ #2 DEFAULT ⇔ #2 CUSTOM                      ⇕                      #6 CUSTOM #3 DEFAULT                      ⇕                      #6 DEFAULT #3 CUSTOM                      ⇕                      #5 CUSTOM ⇔ #5 DEFAULT ⇔ #4 CUSTOM ⇔ #4 DEFAULT</p> <p><b>To adjust CUSTOM</b></p> <p>Selecting a mode whose name includes CUSTOM and then pressing the ► button or the ENTER button displays a dialog to aid you in adjusting the mode. This function is useful when you want to change the brightness of particular tones.</p>  <p>Choose an item using the ◀/▶ buttons, and adjust the level using the ▲/▼ buttons.</p> <p>You can display a test pattern for checking the effect of your adjustment by pressing the ENTER button. Each time you press the ENTER button, the pattern changes as below.</p> <p>No pattern ⇔ Gray scale of 9 steps ⇐                      ⇑ ⇐ Ramp ⇔ Gray scale of 15 steps</p> <p>The eight equalizing bars correspond to eight tone levels of the test pattern (Gray scale of 9 steps), except the darkest in the left end. If you want to adjust the 2nd tone from left end on the test pattern use the equalizing adjustment bar "1". The darkest tone at the left end of the test pattern cannot be controlled with any of equalizing adjustment bar.</p> <ul style="list-style-type: none"> <li>• When this function is performed, lines or other distortion may appear.</li> </ul>

(continued on next page)

PICTURE menu (continued)

Item	Description
<p><b>COLOR TEMP</b></p>	<p>Using the ▲/▼ buttons switches the color temperature mode.</p> <p>#1 HIGH DEFAULT ⇔ #1 HIGH CUSTOM ⇔ #2 MID DEFAULT            ⇕ ⇕            #6 HI-BRIGHT-3 CUSTOM #2 MID CUSTOM            ⇕ ⇕            #6 HI-BRIGHT-3 DEFAULT #3 LOW DEFAULT            ⇕ ⇕            #5 HI-BRIGHT-2 CUSTOM #3 LOW CUSTOM            ⇕ ⇕            #5 HI-BRIGHT-2 DEFAULT ⇔ #4 HI-BRIGHT-1 CUSTOM ⇔ #4 HI-BRIGHT-1 DEFAULT</p> <p><b>To adjust CUSTOM</b></p> <p>Selecting a mode whose name includes CUSTOM and then pressing the ► button or the ENTER button displays a dialog to aid you in adjusting the OFFSET and GAIN of the selected mode.</p>  <p>OFFSET adjustments change the color intensity on the whole tones of the test pattern.</p> <p>GAIN adjustments mainly affect color intensity on the brighter tones of the test pattern.</p> <p>Choose an item using the ◀/▶ buttons, and adjust the level using the ▲/▼ buttons.</p> <p>You can display a test pattern for checking the effect of your adjustment by pressing the ENTER button. Each time you press the ENTER button, the pattern changes as below.</p> <p>No pattern ⇔ Gray scale of 9 steps ⇐↵            ⇐↵ Ramp ⇔ Gray scale of 15 steps</p> <ul style="list-style-type: none"> <li>• When this function is performed, lines or other distortion may appear.</li> </ul>
<p><b>COLOR</b></p>	<p>Using the ▲/▼ buttons adjusts the strength of whole color.</p> <p>Strong ⇔ Weak</p> <ul style="list-style-type: none"> <li>• This item can be selected only for a video signal, s-video or component video signal.</li> </ul>
<p><b>TINT</b></p>	<p>Using the ▲/▼ buttons adjusts the tint.</p> <p>Greenish ⇔ Reddish</p> <ul style="list-style-type: none"> <li>• This item can be selected only for a video signal, s-video or component video signal.</li> </ul>

(continued on next page)

**PICTURE menu (continued)**

Item	Description
<p><b>SHARPNESS</b></p>	<p>Using the ▲/▼ buttons adjusts the sharpness.                      Strong ⇔ Weak</p> <ul style="list-style-type: none"> <li>• There may be some noise and/or the screen may flicker for a moment when an adjustment is made. This is not a malfunction.</li> </ul>
<p><b>MY MEMORY</b></p>	<p>This projector has 4 memories for adjustment data (for all the items of PICTURE menu).                      Selecting a function using the ▲/▼ buttons and pressing the ► or ENTER button performs each function.</p> <div style="text-align: center;"> <p>LOAD-1 ⇔ LOAD-2 ⇔ LOAD-3 ⇔ LOAD-4 ⇔                      SAVE-4 ⇔ SAVE-3 ⇔ SAVE-2 ⇔ SAVE-1</p> </div> <p><b><u>LOAD-1, LOAD-2, LOAD-3, LOAD-4</u></b></p> <p>Performing a LOAD function loads the data from the memory linked in the number included in the function's name, and adjusts the picture automatically depending on the data.</p> <ul style="list-style-type: none"> <li>• The LOAD functions whose linked memory has no data are skipped.</li> <li>• Remember that the current adjusted condition will be lost by loading data. If you want to keep the current adjustment, please save it before performing a LOAD function.</li> <li>• There may be some noise and the screen may flicker for a moment when loading data. This is not malfunction.</li> <li>• You can perform the LOAD function using MY BUTTONs. Please see MY BUTTON item in OPTION menu (44).</li> </ul> <p><b><u>SAVE-1, SAVE-2, SAVE-3, SAVE-4</u></b></p> <p>Performing a SAVE function saves the current adjustment data into the memory linked in the number included in the function's name.</p> <ul style="list-style-type: none"> <li>• Remember that the current data being stored of a memory will be lost by saving a new data into the memory.</li> </ul>



**IMAGE menu (continued)**

Item	Description
<b>H POSITION</b>	<p>Using the ▲/▼ buttons adjusts the horizontal position. Left ⇔ Right</p> <ul style="list-style-type: none"> <li>Over-adjusting the horizontal position may cause noise to appear on the screen. If this occurs please reset the horizontal position to the default setting. Pressing RESET button when H POSITION is selected will reset H POSITION to the default setting.</li> <li>When this function is performed on a video signal, s-video signal, or component video signal, of 525i (480i) or 625i (576i) input from the COMPONENT port, the range of this adjustment depends on OVER SCAN ( <a href="#">☐</a>above) setting. It is not possible to adjust when OVER SCAN is set to 10.</li> </ul>
<b>H PHASE</b>	<p>Using the ▲/▼ buttons adjusts the horizontal phase to eliminate flicker. Right ⇔ Left</p> <ul style="list-style-type: none"> <li>This item can be selected only for a computer signal, a MIU signal or component video signal. (except 525 (480i), 625i (576i), SCART RGB input from the COMPONENT port.)</li> </ul>
<b>H SIZE</b>	<p>Using the ▲/▼ buttons adjusts the horizontal size. Large ⇔ Small</p> <ul style="list-style-type: none"> <li>This item can be selected only for a computer signal or an MIU signal.</li> <li>When this adjustment is excessive, the picture may not be displayed correctly. In such a case, please reset the adjustment by pressing the RESET button during this operation.</li> </ul>
<b>AUTO ADJUST EXECUTE</b>	<p>Executing this item performs the automatic adjustment feature.</p> <p><b>For a computer signal or MIU signal</b> The vertical position, the horizontal position and the horizontal phase ( <a href="#">☐</a>45) will be automatically adjusted. Make sure that the application window is set to its maximum size prior to attempting to use this feature. A dark picture may still be incorrectly adjusted. Use a bright picture when adjusting.</p> <p><b>For a video signal and s-video signal</b> The video format best suited for the respective input signal will be selected automatically. This function is available only when the AUTO is selected for the VIDEO FORMAT item in the INPUT menu ( <a href="#">☐</a>33). The vertical position and horizontal position will be automatically set to the default.</p> <p><b>For a component video signal</b> The vertical position, horizontal position and horizontal phase will be automatically set to the default.</p> <ul style="list-style-type: none"> <li>The automatic adjustment operation requires approx. 10 seconds. Also please note that it may not function correctly with some input. When this function is performed for a video signal, a certain extra such as a line may appear outside a picture.</li> <li>The items adjusted by this function may vary when the FINE or DISABLE is selected for the AUTO ADJUST item of the SERVICE item in the OPTION menu ( <a href="#">☐</a>45).</li> </ul>



## INPUT menu

From the INPUT menu, items shown in the table below can be performed.

Select an item using the ▲/▼ cursor buttons, and press the ► cursor button or ENTER button to execute the item. Then perform it according to the following table.



Item	Description
<b>PROGRESSIVE</b>	<p>Using the ▲/▼ buttons switches the progress mode.            TV ⇄ FILM ⇄ TURN OFF            ↑</p> <ul style="list-style-type: none"> <li>• This function is performed only for an interlaced signal at the VIDEO or S-VIDEO input, and for 525i (480i), 625i (576i) or 1125i (1080i) signal at the COMPONENT VIDEO.</li> <li>• When TV or FILM is selected, the screen image will be sharp. FILM adapts to the 2-3 Pull-Down conversion system. But these may cause a certain defect (for example, jagged line) of the picture for a quick moving object. In such a case, please select TURN OFF, even though the screen image may lose the sharpness.</li> </ul>
<b>VIDEO NR</b>	<p>Using the ▲/▼ buttons switches the noise reduction mode.            HIGH ⇄ MID ⇄ LOW            ↑</p> <ul style="list-style-type: none"> <li>• This function is performed only for the VIDEO or S-VIDEO input, and for 525i (480i), 625i (576i) or 1125i (1080i) signal at the COMPONENT VIDEO.</li> <li>• When this function is excessive, it may cause a certain degradation of the picture.</li> </ul>
<b>COLOR SPACE</b>	<p>Using the ▲/▼ buttons switches the mode for color space.            AUTO ⇄ RGB ⇄ SMPTE240 ⇄ REC709 ⇄ REC601            ↑</p> <ul style="list-style-type: none"> <li>• This item can be selected only for a computer signal or component video signal except SCART RGB signal.</li> <li>• The AUTO mode automatically selects the optimum mode.</li> <li>• The AUTO operation may not work well at some signals. In such a case, it might be good to select a suitable mode except AUTO.</li> </ul>
<b>COMPONENT</b>	<p>Using the ▲/▼ buttons switches the function of the COMPONENT (Y, Cb/Pb, Cr/Pr) port.            COMPONENT ⇄ SCART RGB</p> <p>When the SCART RGB is selected, COMPONENT (Y, Cb/Pb, Cr/Pr) and VIDEO ports will function as a SCART RGB port. A SCART cable is required for a SCART RGB input to the projector. For your reference, see the TECHNICAL part.</p>

(continued on next page)

## INPUT menu (continued)

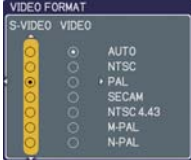
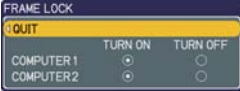
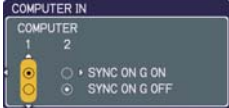
Item	Description
<b>VIDEO FORMAT</b>	<p>The video format for S-VIDEO port and VIDEO port can be set.</p> <p>(1) Use the ◀/▶ buttons to select the input port.</p> <p>(2) Using the ▲/▼ buttons switches the mode for video format.</p> <p>AUTO ⇄ NTSC ⇄ PAL ⇄ SECAM        ↳ N-PAL ⇄ M-PAL ⇄ NTSC4.43 ⬅</p> <ul style="list-style-type: none"> <li>• This item is performed only for a video signal from VIDEO port or S-VIDEO port.</li> <li>• The AUTO mode automatically selects the optimum mode.</li> <li>• The AUTO operation may not work well for some signals. If the picture becomes unstable (e.g. an irregular picture, lack of color), please select the mode according to the input signal.</li> </ul> 
<b>FRAME LOCK</b>	<p>Set the frame lock function on/off for each port.</p> <p>(1) Using the ▲/▼ buttons to select one of following ports.</p> <p>COMPUTER(IN)1 ⇄ COMPUTER(IN)2</p> <p>(2) Using the ◀/▶ buttons to turns the frame lock function on/off.</p> <p>TURN ON ⇄ TURN OFF</p> <ul style="list-style-type: none"> <li>• This item can be performed only on a signal with a vertical frequency of 50 to 60 Hz.</li> <li>• When the TURN ON is selected, a moving pictures are displayed more smoothly.</li> <li>• This function may cause a certain degradation of the picture. In such a case, please select TURN OFF.</li> </ul> 
<b>COMPUTER IN</b>	<p>The computer input signal type for COMPUTER IN1 and IN2 ports can be set.</p> <p>(1) Use the ◀/▶ buttons to select the input port to be set.</p> <p>COMPUTER (IN)1 ⇄ COMPUTER (IN)2</p> <p>(2) Use the ▲/▼ buttons to select the computer input signal type.</p> <p>SYNC ON G ON ⇄ SYNC ON G OFF</p> <p>Selecting SYNC ON G ON allows reception of sync on G signal.</p> <ul style="list-style-type: none"> <li>• When SYNC ON G ON is selected, the picture may be distorted with certain input signals. In such a case, remove the signal connector first and select SYNC ON G OFF on the menu, and then reconnect the signal.</li> </ul> 

(continued on next page)

INPUT menu (continued)

Item	Description
<p><b>RESOLUTION</b></p>	<p>The resolution for the COMPUTER IN1 and IN2 input signals can be set on this projector.</p> <p>(1) In the INPUT menu select the RESOLUTION using the ▲/▼ buttons and press the ► button. The RESOLUTION menu will be displayed.</p> <p>(2) In the RESOLUTION menu, select the resolution you wish to display using the ▲/▼ buttons. Selecting AUTO will set a resolution appropriate to the input signal.</p> <p>(3) STANDARD Pressing the ► or ENTER button when selecting a STANDARD resolution will automatically adjust the horizontal and vertical positions, clock phase and horizontal size and automatically select an aspect ratio.</p> <p>(3) CUSTOM (3)-1 To set a custom resolution use the ▲/▼ buttons to select the CUSTOM and the CUSTOM RESOLUTION box will be displayed. Set the horizontal (HORZ) and vertical (VERT) resolutions using the ▲/▼ /◀/► buttons. It is not guaranteed to work this function properly on any resolutions.</p> <p>(3)-2 To save the setting place the cursor on the right-most digit and press the ► button. The horizontal and vertical positions, clock phase and horizontal size will be automatically adjusted.</p> <p>(3)-3 To revert back to the previous resolution without saving changes place the cursor on the left-most digit and press the ◀ button. The screen will then return to the RESOLUTION menu displaying the previous resolution.</p> <ul style="list-style-type: none"> <li>• For some pictures, this function may not work well.</li> </ul>

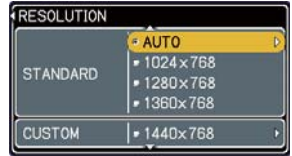

STANDARD



CUSTOM







## SETUP menu

From the SETUP menu, items shown in the table below can be performed.



Select an item using the ▲/▼ cursor buttons, and press the ► cursor button or the ENTER button to execute the item. Then perform it according to the following table.



Item	Description
<p><b>AUTO KEYSTONE EXECUTE</b> </p>	<p>Selecting this item performs the automatic keystone distortion correction. Projector automatically corrects vertical keystone distortion due to the (forward/backward) setup angle by itself. This function will be executed only once when selected in the menu. When the slant of the projector is changed, execute this function again.</p> <ul style="list-style-type: none"> <li>• The adjustable range for correction will vary among inputs. For some input, this function may not work well.</li> <li>• When V:INVERT or H&amp;V:INVERT is selected to the MIRROR item in the SETUP menu, if the projector screen is inclined or angled downward, this function may not work correctly.</li> <li>• When the zoom adjustment is set to the TELE (telephoto focus), this function may be excessive. This function should be used when the zoom adjustment is set to the full WIDE (wide-angle focus) whenever possible.</li> <li>• When the projector is placed on the level (about <math>\pm 3^\circ</math>), this function may not work.</li> <li>• When the projector is inclined to near <math>\pm 30</math> degree or over, this function may not work well.</li> <li>• This function will be unavailable when the Transition Detector is on (51).</li> </ul>
<p><b>KEYSTONE</b> </p>	<p>Using the ▲/▼ buttons corrects the vertical keystone distortion. Shrink the top of the image ⇔ Shrink the bottom of the image</p> <ul style="list-style-type: none"> <li>• The adjustable range of this function will vary with the type of input signal. For some input, this function may not work well.</li> <li>• This function will be unavailable when the Transition Detector is on (51).</li> </ul>

(continued on next page)

**SETUP menu (continued)**

Item	Description
<b>WHISPER</b>	Using the ▲/▼ buttons turns off/on the whisper mode. NORMAL ⇔ WHISPER • When WHISPER is selected, acoustic noise and screen brightness are reduced.
<b>MIRROR</b>	Using the ▲/▼ buttons switches the mode for mirror status.  NORMAL ⇔ H:INVERT ⇔ V:INVERT ⇔ H&V:INVERT  If the Transition Detector is TURN ON and MIRROR status is changed, Transition Detector Alarm (🔊51) will be displayed when projector is restarted after the power switch is turned off.
<b>VOLUME</b>	Using the ▲/▼ buttons adjusts the volume. High ⇔ Low
<b>SPEAKER</b>	Using the ▲/▼ buttons turns on/off the built-in speaker. TURN ON ⇔ TURN OFF When TURN OFF is selected, the built-in speaker does not work.

(continued on next page)

SETUP menu (continued)

Item	Description
<p><b>AUDIO</b></p>	<p>Allocates the audio ports.                      (1) Choose a picture input port using the ▲/▼ buttons.                      ⇩QUIT ⇔ COMPUTER (IN)1 ⇔ COMPUTER (IN)2 ⇩                      VIDEO ⇔ S-VIDEO ⇔ COMPONENT ⇔ MIU                      (2) Select the audio port to be interlocked with the input port using the ◀/▶ buttons.                      [COMPUTER1, COMPUTER2, COMPONENT, S-VIDEO, VIDEO]                      1 ⇔ 2 ⇔ 3 ⇔ ✕                      [MIU]                      1 ⇔ 2 ⇔ 3 ⇔ ✕ ⇔ H</p>  <ul style="list-style-type: none"> <li>• “M” is abbreviations of MIU.</li> <li>• M can be selected for MIU port only. When M is selected, the audio signal to MIU port will be output if MIU is chosen as a display source.</li> <li>• When ✕ is selected for an input, the audio will not be output if the input is chosen as a display source.</li> <li>• When ✕ is selected to VIDEO or S-VIDEO port, the C.C.(Closed Caption) is automatically activated, if the C.C. is set to AUTO in the DISPLAY menu of the C.C. menu and the signal from the input port supports the C.C. feature. (63)</li> </ul>

## SCREEN menu

From the SCREEN menu, items shown in the table below can be performed.

Select an item using the ▲/▼ cursor buttons, and press the ► cursor button or ENTER button to execute the item. Then perform it according to the following table.



Item	Description								
<b>LANGUAGE</b>	<p>Using the ▲/▼ buttons switches the OSD (On Screen Display) language.</p> <p>ENGLISH ⇄ FRANÇAIS ⇄ DEUTSCH ⇄ ESPAÑOL ⇄ ITALIANO                      ⇄                      TÜRKÇE                      ⇄                      POLSKI                      ⇄                      SUOMI                      ⇄                      РУССКИЙ ⇄ SVENSKA ⇄ 한글 ⇄ 繁體中文 ⇄ 简体中文 ⇄ 日本語</p>								
<b>MENU POSITION</b>	<p>Using the ▲/▼/◀/▶ buttons adjusts the menu position.                      To quit the operation, press MENU button on the remote control or keep no operation for about 10 seconds.</p>								
<b>BLANK</b>	<p>Using the ▲/▼ buttons switches the mode for the BLANK screen. The BLANK screen is a screen for the temporarily blanking feature (📺22). It is displayed by pressing BLANK button.</p> <p>MyScreen ⇄ ORIGINAL ⇄ BLUE ⇄ WHITE ⇄ BLACK</p> <p style="text-align: center;">↑—————↑</p> <table border="1" style="width: 100%;"> <thead> <tr> <th></th> <th>Feature</th> </tr> </thead> <tbody> <tr> <td>MyScreen</td> <td>Screen can be registered by the MyScreen item (📺40).</td> </tr> <tr> <td>ORIGINAL</td> <td>Screen preset as the standard screen.</td> </tr> <tr> <td>BLUE, WHITE, BLACK</td> <td>Plain screens in each color.</td> </tr> </tbody> </table> <p>• To avoid remaining as an afterimage, the MyScreen or ORIGINAL screen will change to the plain black screen after several minutes.</p>		Feature	MyScreen	Screen can be registered by the MyScreen item (📺40).	ORIGINAL	Screen preset as the standard screen.	BLUE, WHITE, BLACK	Plain screens in each color.
	Feature								
MyScreen	Screen can be registered by the MyScreen item (📺40).								
ORIGINAL	Screen preset as the standard screen.								
BLUE, WHITE, BLACK	Plain screens in each color.								

(continued on next page)

## SCREEN menu (continued)

Item	Description								
<b>START UP</b>	Using the ▲/▼ buttons switches the mode for the start-up screen. The start-up screen is a screen displayed when no signal or an unsuitable signal is detected.								
	MyScreen ⇄ ORIGINAL ⇄ TURN OFF 								
	<table border="1" style="width: 100%; border-collapse: collapse;"> <thead> <tr> <th style="width: 50%;"></th> <th style="width: 50%;">Feature</th> </tr> </thead> <tbody> <tr> <td data-bbox="319 414 535 470">MyScreen</td> <td data-bbox="535 414 1013 470">Screen can be registered by the MyScreen item (M40).</td> </tr> <tr> <td data-bbox="319 470 535 502">ORIGINAL</td> <td data-bbox="535 470 1013 502">Screen preset as the standard screen.</td> </tr> <tr> <td data-bbox="319 502 535 526">TURN OFF</td> <td data-bbox="535 502 1013 526">Plain black screen.</td> </tr> </tbody> </table>		Feature	MyScreen	Screen can be registered by the MyScreen item (M40).	ORIGINAL	Screen preset as the standard screen.	TURN OFF	Plain black screen.
		Feature							
	MyScreen	Screen can be registered by the MyScreen item (M40).							
ORIGINAL	Screen preset as the standard screen.								
TURN OFF	Plain black screen.								
<table border="1" style="width: 100%; border-collapse: collapse;"> <thead> <tr> <th style="width: 50%;"></th> <th style="width: 50%;">Feature</th> </tr> </thead> <tbody> <tr> <td data-bbox="319 414 535 470">MyScreen</td> <td data-bbox="535 414 1013 470">Screen can be registered by the MyScreen item (M40).</td> </tr> <tr> <td data-bbox="319 470 535 502">ORIGINAL</td> <td data-bbox="535 470 1013 502">Screen preset as the standard screen.</td> </tr> <tr> <td data-bbox="319 502 535 526">TURN OFF</td> <td data-bbox="535 502 1013 526">Plain black screen.</td> </tr> </tbody> </table>		Feature	MyScreen	Screen can be registered by the MyScreen item (M40).	ORIGINAL	Screen preset as the standard screen.	TURN OFF	Plain black screen.	
	Feature								
MyScreen	Screen can be registered by the MyScreen item (M40).								
ORIGINAL	Screen preset as the standard screen.								
TURN OFF	Plain black screen.								
<table border="1" style="width: 100%; border-collapse: collapse;"> <thead> <tr> <th style="width: 50%;"></th> <th style="width: 50%;">Feature</th> </tr> </thead> <tbody> <tr> <td data-bbox="319 414 535 470">MyScreen</td> <td data-bbox="535 414 1013 470">Screen can be registered by the MyScreen item (M40).</td> </tr> <tr> <td data-bbox="319 470 535 502">ORIGINAL</td> <td data-bbox="535 470 1013 502">Screen preset as the standard screen.</td> </tr> <tr> <td data-bbox="319 502 535 526">TURN OFF</td> <td data-bbox="535 502 1013 526">Plain black screen.</td> </tr> </tbody> </table>		Feature	MyScreen	Screen can be registered by the MyScreen item (M40).	ORIGINAL	Screen preset as the standard screen.	TURN OFF	Plain black screen.	
	Feature								
MyScreen	Screen can be registered by the MyScreen item (M40).								
ORIGINAL	Screen preset as the standard screen.								
TURN OFF	Plain black screen.								
<ul style="list-style-type: none"> <li>• To avoid remaining as an afterimage, the MyScreen or ORIGINAL screen will change to the BLANK screen (M38) after several minutes. If also the BLANK screen is the MyScreen or ORIGINAL, the plain black screen is instead used.</li> <li>• When the TURN ON is selected to the MyScreen PASSWORD of SECURITY item in OPTION menu (M48), the START UP is fixed to MyScreen.</li> </ul>									

(continued on next page)

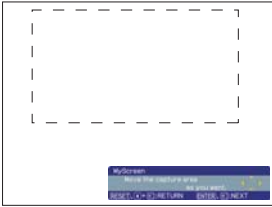

SCREEN menu (continued)

Item	Description
<p><b>MyScreen</b></p>	<p>This item allows you to capture an image for use as a MyScreen image which can be used as the BLANK screen and START UP screen. Display the image you want to capture before executing the following procedure.</p> <ol style="list-style-type: none"> <li>1. Selecting this item displays a dialog titled “MyScreen”. It will ask you if you start capturing an image from the current screen.                      <p>Please wait for the target image to be displayed, and press the ENTER button when the image is displayed. The image will freeze and the frame for capturing will appear. To stop performing, press the RESET or ESC button.</p> </li> <li>2. Using the ▲/▼/◀/▶ buttons adjusts the frame position.                      <p>Please move the frame to the position of the image which you want to use. The frame may not be able to be moved for some input signals. To start registration, press the ENTER button. To restore the screen and return to the previous dialog, press the RESET or ESC button. Registration takes several minutes. When the registration is completed, the registered screen and the following message are displayed for several seconds: <b>“MyScreen registration is finished.”</b> If the registration failed, the following message is displayed: <b>“A capturing error has occurred. Please try again.”</b></p> <ul style="list-style-type: none"> <li>• This function cannot be selected when the TURN ON is selected to the MyScreen Lock item (<a href="#">📄 below</a>).</li> <li>• This function cannot be selected when TURN ON is selected to the MyScreen PASSWORD of SECURITY item in OPTION menu (<a href="#">📄 48</a>).</li> </ul> </li> </ol>
<p><b>MyScreen Lock</b></p>	<p>Using the ▲/▼ buttons turns on/off the MyScreen lock function.</p> <p>TURN ON ⇔ TURN OFF</p> <p>When the TURN ON is selected, the MyScreen item is locked. Use this function for protecting the current MyScreen.</p> <ul style="list-style-type: none"> <li>• This function cannot be selected when TURN ON is selected to the MyScreen PASSWORD of SECURITY item in OPTION menu (<a href="#">📄 48</a>).</li> </ul>

(continued on next page)

## SCREEN menu (continued)



Item	Description
MESSAGE	<p>Using the ▲/▼ buttons turns on/off the message function. TURN ON ⇔ TURN OFF</p> <p>When the TURN ON is selected, the following message function works. “AUTO IN PROGRESS” while automatically adjusting “NO INPUT IS DETECTED” “SYNC IS OUT OF RANGE” “Searching...” while searching for the input “Detecting...” while an input signal is detected The indication of the input signal displayed by changing The indication of the aspect ratio displayed by changing The indication of the PICTURE MODE displayed by changing The indication of the MY MEMORY displayed by changing The indication of “FREEZE” and “I” while the projector is in the FREEZE mode.</p> <ul style="list-style-type: none"> <li>• If the projector goes into the FREEZE mode while the TURN OFF is selected, the picture on screen is frozen without any messages, which is not a malfunction. (  22 )</li> </ul>
SOURCE NAME	<p>Each input port for this projector can have a name applied to it.</p> <p>(1) Use the ▲/▼ buttons on the SCREEN menu to select SOURCE NAME and press the ► button. The SOURCE NAME menu will be displayed.</p> <p>(2) Use the ▲/▼ buttons on the SOURCE NAME menu to select the port to be named and press the ► button. Right side of the menu is blank until a name is specified. The SOURCE NAME dialog will be displayed.</p> <p>(3) The current name will be displayed on the first line. Use the ▲/▼/◀/▶ buttons and the ENTER or INPUT button to select and enter characters. The RESET button can be used to erase 1 character at a time. Also if you move the cursor to DELETE or ALL CLEAR on screen and push the ENTER or INPUT button, 1 character or all characters will be erased. The name can be a maximum of 16 characters.</p> <p>(4) To change an already inserted character, press the (▲) button to move the cursor to the first line, and use the ◀/▶ buttons to move the cursor on the character to be changed. After pressing the ENTER or INPUT button, the character is selected. Then, follow the same procedure as described at the item (3) above.</p> <p>(5) To finish entering text, move the cursor to the SAVE on screen and press the ENTER or INPUT button. To revert to the previous name without saving changes, move the cursor to the CANCEL on screen and press the ENTER or INPUT button.</p> <div data-bbox="800 746 1019 869"> </div> <div data-bbox="789 885 1036 1013"> </div> <div data-bbox="789 1029 1036 1157"> </div> <div data-bbox="789 1189 1036 1316"> </div>

OPTION menu

From the OPTION menu, items shown in the table below can be performed.

Select an item using the ▲/▼ cursor buttons, and press the ► cursor button or ENTER button to execute the item, except for the items LAMP TIME and FILTER TIME. Then perform it according to the following table.



Item	Description
<b>AUTO SEARCH</b>	<p>Using the ▲/▼ buttons turns on/off the automatic signal search function. TURN ON ⇔ TURN OFF</p> <p>When the TURN ON is selected, detecting no signal automatically cycles through input ports in the following order. The search is started from the current port. Then when an input is found, the projector will stop searching and display the image.</p> <pre>     graph LR       A[COMPUTER IN1] --&gt; B[COMPUTER IN2]       B --&gt; C[MIU]       C --&gt; D[COMPONENT]       D --&gt; E[S-VIDEO]       E --&gt; F[VIDEO]       F --&gt; A     </pre>
<b>AUTO KEYSTONE</b> 	<p>Using the ▲/▼ buttons turns on/off the automatic keystone function. TURN ON ⇔ TURN OFF</p> <p>TURN ON : Automatic keystone distortion correction will be executed whenever changing the slant of the projector. TURN OFF : This function is disabled. Please execute the AUTO KEYSTONE  EXECUTE in the SETUP Menu for automatic keystone distortion correction.</p> <ul style="list-style-type: none"> <li>• When the projector is suspended from the ceiling this feature will not function properly so select the TURN OFF.</li> <li>• This function will be unavailable when the Transition Detector is on (<a href="#">p.51</a>).</li> </ul>
<b>AUTO ON</b>	<p>Using the ▲/▼ buttons turns on/off the AUTO ON function. TURN ON ⇔ TURN OFF</p> <p>When set to the TURN ON, the lamp in projector will be automatically turned on without the usual procedure (<a href="#">p.16</a>), only when the projector is supplied with the power after the power was cut while the lamp was on.</p> <ul style="list-style-type: none"> <li>• This function does not work as long as the power has been supplied to the projector while the lamp is off.</li> <li>• After turning the lamp on by the AUTO ON function, if neither input nor operation is detected for about 30 minutes, the projector is turned off, even though the AUTO OFF function (<a href="#">p.43</a>) is disabled.</li> </ul>

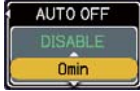

(continued on next page)

## OPTION menu (continued)

Item	Description
<b>AUTO OFF</b>	<p>Using the ▲/▼ buttons adjusts the time to count down to automatically turn the projector off.            Long (max. 99 minutes) ⇔ Short (min. 0 minute = DISABLE)</p> <div style="display: flex; justify-content: space-around; align-items: center;">   </div> <p>When the time is set to 0, the projector is not turned off automatically. When the time is set to 1 to 99, and when the passed time with no-signal or an unsuitable signal reaches at the set time, the projector lamp will be turned off.</p> <p>If one of the projector's buttons or the remote control buttons is pressed or one of the commands (except get commands) is transmitted to the CONTROL port during the corresponding time, projector will not be turned off.</p> <p>Please refer to the section "Turning off the power" (16).</p>
<b>LAMP TIME</b>	<p>The lamp time is the usage time of the lamp, counted after the last resetting. It is shown in the OPTION menu.</p> <p>Pressing RESET button or the ► button displays a dialog.</p> <p>To reset the lamp time, select RESET using the ▲ button.</p> <p>RESET ⇔ CANCEL</p> <ul style="list-style-type: none"> <li>• Please reset the lamp time only when you have replaced the lamp, for a suitable indication about the lamp.</li> <li>• For the lamp replacement, see the section "Lamp" (64).</li> </ul>
<b>FILTER TIME</b>	<p>The filter time is the usage time of the air filter, counted after the last resetting. It is shown in the OPTION menu.</p> <p>Pressing the RESET button or the ► button displays a dialog.</p> <p>To reset the filter time, select the RESET using the ▲ button.</p> <p>RESET ⇔ CANCEL</p> <ul style="list-style-type: none"> <li>• Please reset the filter time only when you have cleaned or replaced the air filter, for a suitable indication about the air filter.</li> <li>• For the air filter cleaning, see the section "Air filter" (66).</li> </ul>

(continued on next page)

OPTION menu (continued)

Item	Description
<p><b>MY BUTTON</b></p>	<p>This item is to assign one of the following functions to MY BUTTON 1 and 2 on the remote control (46).            Choose 1 or 2 on the MY BUTTON menu using the ◀/▶ button first. Then using the ▲/▼ buttons sets one of the following functions to the chosen button.</p> <ul style="list-style-type: none"> <li>• COMPUTER1: Sets port to COMPUTER IN1.</li> <li>• COMPUTER2: Sets port to COMPUTER IN2.</li> <li>• MIU: Sets port to MIU.</li> <li>• COMPONENT: Sets port to COMPONENT(Y, Cb/Pb, Cr/Pr)</li> <li>• S-VIDEO: Sets port to S-VIDEO.</li> <li>• VIDEO: Sets port to VIDEO.</li> <li>• INFORMATION: Displays the INPUT-INFORMATION- (46) or MIU-INFORMATION- (62) or nothing.</li> </ul> <p>The displayed dialog is switched as below every time the MY BUTTON is pushed.</p> <p>When an input signal is found:            INPUT -INFORMATION- → MIU -INFORMATION- → OFF</p>  <p>When an input signal is not found:            MIU -INFORMATION- ⇔ OFF</p> <ul style="list-style-type: none"> <li>• AUTO KEYSTONE (7) :            Performs automatic keystone distortion correction (35).</li> <li>• MY MEMORY: Loads one of adjustment data stored (29).            When more than one data are saved, the adjustment changes every time the MY BUTTON is pushed.            When no data is saved in memory, the dialog "No saved data" appears.            When the current adjustment is not saved to memory, the dialog as shown in the right appears.</li> </ul>  <p>If you want to keep the current adjustment, please press the ◀ button to quit. Otherwise loading a data will lose the current adjusted condition.</p> <ul style="list-style-type: none"> <li>• PICTURE MODE: Changes the PICTURE MODE (25).</li> <li>• FILTER RESET: Displays the filter time reset confirmation dialogue (43).</li> <li>• VOLUME+: Set the volume up.</li> <li>• VOLUME-: Set the volume down.</li> <li>• e-SHOT: Displays the e-SHOT menu (61).</li> <li>• LIVE MODE : Sets port to MIU and display an image on the LIVE MODE.            While using the LIVE MODE, the LIVE MODE SETTING menu is displayed.</li> <li>• THUMBNAIL : Sets port to MIU and displays the THUMBNAIL screen.</li> <li>• SLIDE SHOW : Sets port to MIU and starts the SLIDE SHOW display.</li> <li>• DIRECTORY : Sets port to MIU and displays the DIRECTORY screen.</li> <li>• REMOVE MEDIA : Displays the REMOVE MEDIA menu.</li> </ul>
<p><b>SERVICE</b></p>	<p>Selecting this item displays the SERVICE menu.            Select an item using the ▲/▼ buttons, and press the ▶ button or the ENTER button to execute the item.</p> <p>FAN SPEED ⇔ AUTO ADJUST ⇔ GHOST ⇔ FILTER MESSAGE ⇔ KEY LOCK</p> 

(continued on next page)

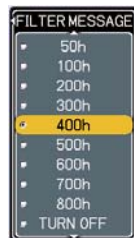

## OPTION menu (continued)

Item	Description
SERVICE (continued)	<p><b>FAN SPEED</b> Using the ▲/▼ buttons the rotation speed of the cooling fans. The HIGH is the mode for use at highlands etc. Note that the projector is noisier when the HIGH is selected. HIGH ⇄ NORMAL</p>
	<p><b>AUTO ADJUST</b> Using the ▲/▼ buttons to select one of the mode. When the DISABLE is selected, the automatic adjustment feature is disabled. FINE ⇄ FAST ⇄ DISABLE</p> <p style="text-align: center;">↑—————↑</p> <p>FINE: Finer tuning including H.SIZE adjustment. FAST: Faster tuning, setting H.SIZE to prearranged data for the input signal.</p> <ul style="list-style-type: none"> <li>Depending on conditions, such as input image, signal cable to the projector, environment around the projector, etc., the automatic adjustment may not work correctly. In such a case, please choose DISABLE to disable the automatic adjustment, and make adjustment manually.</li> </ul>
	<p><b>GHOST</b> 1. Select a color element of ghost using the ◀/▶ buttons. 2. Adjust the selected element using the ▲/▼ buttons to disappear ghost.</p>
	<p><b>FILTER MESSAGE</b> Use the ▲/▼ button to set the timer for the interval to show the message for cleaning up the air filter. 50h ⇄ 100h ⇄ 200h ⇄ 300h ⇄ 400h ⇄ 500h TURN OFF ⇄ 800h ⇄ 700h ⇄ 600h ↶</p> <p>After choosing an item except TURN OFF, the message "REMINDER *** HRS PASSED AFTER THE LAST FILTER CHECK" will appear after the timer reaches the interval time set by this feature (70). When the TURN OFF is chosen, the message will not appear. Utilize this feature to keep the air filter clean, setting the suitable time according to your environment of this projector.</p> <ul style="list-style-type: none"> <li>Please check and clean the air filter periodically, even if there is no message. If the air filter becomes to be blocked by dust or others, the internal temperature will rise, which could cause malfunction, or reduce the lifetime of the projector.</li> <li>Please be careful with the operating environment of the projector and the condition of the air filter.</li> </ul>





(continued on next page)

OPTION menu (continued)

Item	Description
<p><b>SERVICE</b> (continued)</p>	<p><b>KEY LOCK</b> Using the ▲/▼ buttons turns on/off the key lock feature. When TURN ON is selected, the buttons on the projector except the STANDBY/ON button are locked. TURN ON ⇔ TURN OFF</p> <ul style="list-style-type: none"> <li>• Please use to avoid a mischief and touching accidentally. This function does not have any effect on the remote control.</li> </ul>
	<p><b>REMOTE FREQ.</b> Use the ▲/▼ button to change the projector's remote sensor setting. 1:NORMAL ⇔ 2:HIGH</p> <p>Items with a checkmark are on. The factory default setting is for both 1:NORMAL and 2: HIGH to be on. If the remote control does not function correctly set this to either only 1 or only 2 (▲15).</p> <p>Neither can be turned off at the same time.</p> 
	<p><b>INFORMATION</b> Selecting this item displays a dialog titled "INPUT -INFORMATION-". It shows the information about the current input.</p>  <ul style="list-style-type: none"> <li>• The "FRAME LOCK" message on the dialog means the frame lock function is working (▲33).</li> <li>• This item can't be selected for no signal and sync out.</li> </ul>
	<p><b>FACTORY RESET</b> Selecting RESET using the button ▲ performs this function. By this function, all the items in all of menus will collectively return to the initial setting. Note that the items LAMP TIME, FILTER TIME, LANGUAGE, SECURITY and MIU settings are not reset. RESET ⇔ CANCEL</p>

(continued on next page)

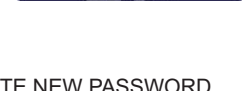

OPTION menu (continued)

Item	Description
<p style="text-align: center;"><b>SECURITY</b></p>	<p>This projector is equipped with security functions. User registration is required before using the security functions. Please contact your local dealer.</p>
	<p><b>1. Using Security Features</b></p>
	<p><b>1.1 Inputting the PASSWORD</b></p>
	<p>1.1-1 Use the ▲/▼ buttons on the OPTION menu to select SECURITY and press the ► button. The ENTER PASSWORD box will be displayed.</p> <p>The factory default PASSWORD is <b>8471</b>. This PASSWORD can be changed (1.2 Changing the PASSWORD (below)).</p> <ul style="list-style-type: none"> <li>It is strongly recommended the factory default PASSWORD to be changed as soon as possible.</li> </ul> <p>1.1-2 Use the ▲/▼/◀/▶ buttons to enter the registered PASSWORD. Move the cursor to the right side of the ENTER PASSWORD box and press the ► button to display the SECURITY menu.</p> <p>If an incorrect PASSWORD is input the ENTER PASSWORD box will be displayed again. If incorrect PASSWORD is input 3 times the projector will turn off. Afterwards the projector will turn off every time an incorrect PASSWORD is input.</p>
<p><b>1.2 Changing the PASSWORD</b></p>	
<p>1.2-1 Use the ▲/▼ buttons on the SECURITY menu to select SECURITY PASSWORD CHANGE and press the ► button to display the ENTER NEW PASSWORD box.</p>	
<p>1.2-2 Use the ▲/▼/◀/▶ buttons to enter the new PASSWORD.</p>	
<p>1.2-3 Move the cursor to the right side of the ENTER NEW PASSWORD box and press the ► button to display the NEW PASSWORD AGAIN box, enter the same PASSWORD again.</p>	
<p>1.2-4 Move the cursor to the right side of the NEW PASSWORD AGAIN box and press the ► button and the NOTE NEW PASSWORD box will be displayed for about 20 seconds, please make note of the PASSWORD during this time.</p> <p>Pressing the ENTER button will close the NOTE NEW PASSWORD box.</p> <ul style="list-style-type: none"> <li>Please do not forget your PASSWORD.</li> </ul>	

(continued on next page)



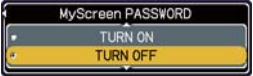

OPTION menu (continued)

Item	Description
<p><b>SECURITY</b> (continued)</p>	<p><b>1.3 If you have forgotten your PASSWORD</b></p> <p>1.3-1 Follow the procedure in 1.1-1 to display the ENTER PASSWORD box.</p> <p>1.3-2 While the ENTER PASSWORD box is displayed, press and hold the RESET button for about 3 seconds or press and hold the INPUT and ► buttons on the projector for about 3 seconds. The 10-digit Inquiring Code will be displayed.</p> <ul style="list-style-type: none"> <li>• If there is no key input for about 55 seconds while the Inquiring Code is displayed the menu will close. If necessary repeat the process from 1.3-1.</li> </ul> <p>1.3-3 Contact your dealer with the 10-digit Inquiring Code. Your PASSWORD will be sent after your user registration information is confirmed.</p>
	<p><b>2. Using the MyScreen PASSWORD Function</b></p> <p>The MyScreen PASSWORD function can be used to prohibit access to the MyScreen function and prevent the currently registered MyScreen image from being overwritten.</p> <p><b>2.1 Turning on the MyScreen PASSWORD Function</b></p> <p>2.1-1 Use the ▲/▼ buttons on the SECURITY menu to select MyScreen PASSWORD and press the ► button to display the MyScreen PASSWORD on/off menu.</p>  <p><b>2.2 Setting the PASSWORD</b></p> <p>2.2-1 Display the MyScreen PASSWORD on/off menu using the procedure in 2.1-1.</p> <p>2.2-2 Use the ▲/▼ buttons on the MyScreen PASSWORD on/off menu to select TURN ON. The ENTER PASSWORD box (small) will be displayed.</p>  <p>2.2-3 Use the ▲/▼/◀/▶ buttons to enter the PASSWORD. Move the cursor to the right side of the ENTER PASSWORD box (small) and press the ► button to display the PASSWORD AGAIN box, enter the same PASSWORD again.</p> 

(continued on next page)

OPTION menu (continued)

Item	Description
<p><b>SECURITY</b> (continued)</p>	<p>2.2-4 Move the cursor to the right side of the PASSWORD AGAIN box and press the ► button to display the PASSWORD for about 20 seconds, please make note of the PASSWORD during this time.</p>  <p>Pressing the ENTER button will return to MyScreen PASSWORD on/off menu.</p> <p>When a PASSWORD is set for MyScreen:</p> <ul style="list-style-type: none"> <li>• The MyScreen registration function (and menu) will be unavailable.</li> <li>• The MyScreen Lock menu will be unavailable.</li> <li>• The START UP setting will be locked on MyScreen (and the menu will be unavailable).</li> </ul> <p>Turning the MyScreen PASSWORD off will allow normal operation of these functions.</p> <ul style="list-style-type: none"> <li>• Please do not forget your MyScreen PASSWORD.</li> </ul> <p><b>2.3 Turning the PASSWORD off</b></p> <p>2.3-1 Follow the procedure in 2.1-1 to display the MyScreen PASSWORD on/off menu.</p> <p>2.3-2 Select TURN OFF to display the ENTER PASSWORD box (large). Enter the registered PASSWORD and the screen will return to the MyScreen on/off menu.</p> <p>If an incorrect PASSWORD is input the menu will close. If necessary repeat the process from 2.3-1.</p> <p><b>2.4 If you have forgotten your PASSWORD</b></p> <p>2.4-1 Follow the procedure in 2.1-1 to display the MyScreen PASSWORD on/off menu.</p> <p>2.4-2 Select TURN OFF to display the ENTER PASSWORD box (large). The 10-digit Inquiring Code will be displayed inside the box.</p>  <p>2.4-3 Contact your dealer with the 10-digit Inquiring Code. Your PASSWORD will be sent after your user registration information is confirmed.</p>
	<p><b>3. Using the PIN LOCK Function</b></p> <p>PIN LOCK is a function which prevents the projector from being used unless a registered Code is input.</p> <p><b>3.1 Registering the PIN Code</b></p> <p>3.1-1 Use the ▲/▼ buttons on the SECURITY menu to select PIN LOCK and press the ► button or the ENTER button to display the PIN LOCK on/off menu.</p> 

(continued on next page)

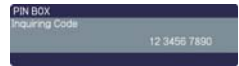
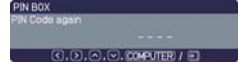

**OPTION menu (continued)**

Item	Description
<p><b>SECURITY</b> (continued)</p>	<p>3.1-2 Use the ▲/▼ buttons on the PIN LOCK on/off menu to select TURN ON and the PIN BOX will be displayed.</p> <p>3.1-3 Input a 4 part PIN Code using the ▲, ▼, ◀, ▶, COMPUTER and INPUT buttons. A PIN Code again box will appear. Reenter the same PIN Code. This will complete the PIN Code registration.</p> <ul style="list-style-type: none"> <li>• If there is no key input for about 55 seconds while the PIN BOX or the PIN Code again box are displayed the menu will close. If necessary repeat the process from 3.1-1.</li> </ul> <p>Afterwards, anytime the projector is restarted after AC power is turned off the PIN BOX will be displayed. Enter the registered PIN Code. The projector can be used after entering the registered PIN Code. If an incorrect PIN Code is input the PIN BOX will be displayed again. If an incorrect PIN Code is input 3 times the projector will turn off. Afterwards the projector will turn off every time an incorrect PIN Code is input. The projector will also turn off if there is no key input for about 5 minutes while the PIN BOX is displayed. This function will activate only when the projector is started after AC power is turned off.</p> <ul style="list-style-type: none"> <li>• Please do not forget your PIN Code.</li> </ul>
	<p><b>3.2 Turning Off the PIN LOCK Function</b></p> <p>3.2-1 Follow the procedure in 3.1-1 to display the PIN LOCK on/off menu. Use the ▲/▼ buttons to select TURN OFF and the PIN BOX will be displayed. Enter the registered PIN Code to turn the PIN LOCK function off. If an incorrect PASSWORD is input 3 times, the menu will close.</p>
	<p><b>3.3 If you have forgotten your PIN Code</b></p> <p>3.3-1 While the PIN BOX is displayed, press and hold the RESET button for 3 seconds or press and hold the INPUT and ▶ buttons for 3 seconds. The 10-digit Inquiring Code will be displayed.</p> <ul style="list-style-type: none"> <li>• If it passes for about 5 minutes after the PIN BOX is displayed the projector will turn off.</li> </ul> <p>3.3-2 Contact your dealer with the 10-digit Inquiring Code. Your PASSWORD will be sent after your user registration information is confirmed.</p>

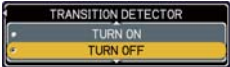
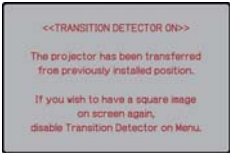

(continued on next page)

OPTION menu (continued)

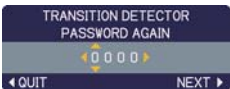
Item	Description
<p><b>SECURITY</b> (continued)</p>	<p><b>4. Using the Transition Detector Function</b></p> <p>While the Transition Detector function is ON, when power switch is started to supply to the projector, it might react as below.</p> <ul style="list-style-type: none"> <li>• Transition Detector alarm shown below might appear on screen, if the projector has been moved or re-installed.</li> <li>• Transition Detector alarm might appear on screen, if the MIRROR setting has been changed.</li> <li>• Keystone adjustment feature has been prohibited as long as the Transition Detector function is ON.</li> </ul> <p><b>4.1 Turning On the Transition Detector Function</b></p> <p>4.1-1 Use the ▲/▼ buttons on the SECURITY menu to select TRANSITION DETECTOR and press the ► or the ENTER button to display the TRANSITION DETECTOR on/off menu. Select TURN ON and the current angle and mirror setting will be recorded.</p>  <ul style="list-style-type: none"> <li>• This feature may not function properly if the projector is not in a stable position when TURN ON is selected.</li> </ul> <p>4.1-2 If this function is set to TURN ON when the vertical angle of the projector or mirror setting at which the projector is turned on is different than the previously recorded the Transition Detector alarm will be displayed and the projector will not display the input signal.</p>  <p>Set the Transition Detector off in the SECURITY menu to display the input signal.</p> <p>If the Transition Detector alarm is displayed for about 5 minutes the lamp will turn off. This function will activate only when the projector is started after turning off the AC power.</p> <p><b>4.2 Setting the Transition Detector PASSWORD</b></p> <p>4.2-1 Use the ▲/▼ buttons on the SECURITY menu to select TRANSITION DETECTOR and press the ► or the ENTER button to display the TRANSITION DETECTOR on/off menu.</p> <p>4.2-2 Use the ▲/▼ buttons on the TRANSITION DETECTOR on/off menu to select TURN ON. The ENTER PASSWORD box (small) will be displayed.</p>  <p>4.2-3 Use the ▲/▼/◀/▶ buttons to enter a PASSWORD. Move the cursor to the right side of the ENTER PASSWORD box (small) and press the ► button to display the PASSWORD AGAIN box, enter the same PASSWORD again.</p> 

(continued on next page)

**OPTION menu (continued)**

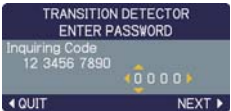
Item	Description
<p><b>SECURITY</b> (continued)</p>	<p>4.2-4 Move the cursor to the right side of the PASSWORD AGAIN box and press the ► button to display the PASSWORD for about 20 seconds, please make note of the PASSWORD during this time.</p> <p>Pressing the ENTER button will return to the TRANSITION DETECTOR on/off menu.</p> <ul style="list-style-type: none"> <li>• Please do not forget your Transition Detector PASSWORD.</li> </ul>
	<p><b>4.3 Setting the Transition Detector off</b></p>
	<p>4.3-1 Follow the procedure in 4.1-1 to display the TRANSITION DETECTOR on/off menu.</p>
	<p>4.3-2 Select TURN OFF to display the ENTER PASSWORD box (large). Enter the registered PASSWORD and the screen will return to the TRANSITION DETECTOR on/off menu. If an incorrect PASSWORD is input the menu will close. If necessary repeat the process from 4.3-1.</p>
	<p><b>4.4 If you have forgotten your PASSWORD</b></p>
<p>4.4-1 Follow the procedure in 4.1-1 to display the TRANSITION DETECTOR on/off menu.</p>	
<p>4.4-2 Select TURN OFF to display the ENTER PASSWORD box (large). The 10-digit Inquiring Code will be displayed inside the box.</p>	
<p>4.4-3 Contact your dealer with the 10-digit Inquiring Code. Your PASSWORD will be sent after your user registration information is confirmed.</p>	

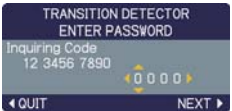
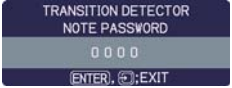

## MIU menu

The MIU (Multi Information processing Unit) is a function to support the Network features and PC-LESS Presentation. Remember that incorrect network settings on this projector may cause trouble on the network. Be sure to consult with your network administrator before connecting to an existing access point on your network.

Select "MIU" from the main menu to access the following functions.

Select an item using the ▲/▼ cursor buttons on the projector or remote control, and press the ► cursor button on the projector or remote control, or ENTER button on the remote control to execute the item. Then perform it according to the following table.

See the User's Manual - Network Guide for details of MIU operation.

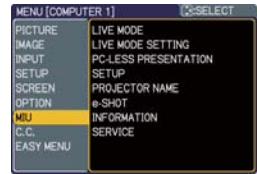

**NOTE** • The factory default setting for DHCP is OFF. If your network has DHCP enabled, and needs to set IP ADDRESS, SUBNET MASK and DEFAULT GATEWAY automatically, please set DHCP to ON. (📖 **Network Settings of the User's Manual - Network Guide**)

• If you are not utilizing SNTF (📖 **Date/Time Settings of the User's Manual - Network Guide**), then you must set the DATE AND TIME (📖57) during the initial installation.

Item	Description
LIVE MODE	Selecting this item sets the projector onto the "Live Mode". On the "Live Mode", the projector displays the images from the PC via Network, supported by "MIU Live Viewer". (📖 <b>Live Mode of the User's Manual - Network Guide</b> ) In the Live Mode, the message "Waiting for connection" will be displayed until the "MIU Live Viewer" start to send computer screen image.
LIVE MODE SETTING	Selecting this item displays the LIVE MODE SETTING menu. Use the ▲/▼ buttons to select an item, and the ► or ENTER button to perform the item.

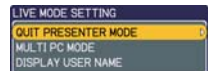

(continued on next page)



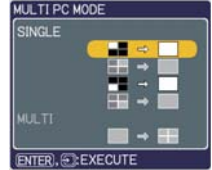

MIU menu (continued)

Item	Description	
<p><b>LIVE MODE SETTING</b> (continued)</p>	<p><b>QUIT PRESENTER MODE</b></p>	<p>The Presenter Mode that is set in the Live Viewer 3 software installed into your PC can be turned off.</p> <p>A message, QUIT PRESENTER MODE, will be displayed in about 3 seconds when the function is performed. The function is available only when the Presenter Mode is set to on in the Live Viewer 3 software.</p> <p>The current setting of the Presenter Mode is shown in the menu.</p> <ul style="list-style-type: none"> <li>• The Presenter mode is a function that allows the projector to display an image sent by 1 PC only, even though the MIU feature on this projector support Multi PC mode.</li> <li>• If the projector is required to display an image sent by other PC, execute the QUIT PRESENTER MODE function.</li> <li>• See the User's Manual – Network Guide for details. (84)</li> </ul>
	<p><b>MULTI PC MODE</b></p>	<p>The projector supports the Single PC mode that displays an image on full screen sent by 1 PC, and the Multi PC mode that divides the screen into 4 zone and displays images in each zone sent by up to 4 PCs. The MULTI PC MODE function switches these modes.</p> <p><b>SINGLE</b></p> <p>Use the ▲/▼ buttons to select an item, and the ENTER or INPUT button to perform the item. The mode will be switched from the Multi PC mode to the Single PC mode and the quarter screen identified in the menu will be displayed on full screen.</p> <p><b>MULTI</b></p> <p>Use the ENTER or INPUT button to perform the item. The mode will be switched to the Multi PC mode and the screen will be divided to 4 zones.</p> <ul style="list-style-type: none"> <li>• If the Presenter Mode is set to on in the PC whose image is currently displayed on screen, a message, QUIT PRESENTER MODE, will be displayed in about 3 seconds when the function is performed.</li> <li>• The function is available when there is any PC connected to the projector in the Multi PC mode set in the Live Viewer 3 software.</li> </ul>

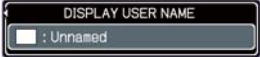

(continued on next page)

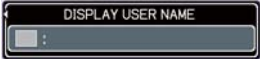



MIU menu (continued)

Item	Description					
<p><b>LIVE MODE SETTING</b> (continued)</p>	<p><b>DISPLAY USER NAME</b></p>	<p>Selecting this item displays the Display User Name defined in the Live View3 software in the PC whose image is on screen.</p> <p><b>SINGLE PC mode</b> The Display User Name will be shown in the DISPLAY USER NAME box.</p>  <p>Examples Display User name Shown in the DISPLAY USER NAME box</p> <table border="0" data-bbox="460 523 901 628"> <tr> <td>PC_NAME0001 (remained as default)</td> <td>PC_NAME0001 Unnamed</td> </tr> <tr> <td>(blank space ) (prohibited showing)</td> <td>(Anonymous)</td> </tr> </table> <p>If there is no PC in the Single PC mode connected to the projector, the DISPLAY USER NAME box is shown as right.</p>  <p><b>MULTI PC mode</b> The Display User Names will be shown in the DISPLAY USER NAME box.</p>  <ul style="list-style-type: none"> <li>• See the User's Manual – Network Guide for details of the Display User Name setting. ( 22)</li> </ul>	PC_NAME0001 (remained as default)	PC_NAME0001 Unnamed	(blank space ) (prohibited showing)	(Anonymous)
		PC_NAME0001 (remained as default)	PC_NAME0001 Unnamed			
(blank space ) (prohibited showing)	(Anonymous)					
<p><b>PC-LESS PRESENTATION</b></p>	<p>Selecting this item displays the PC-LESS PRESENTATION menu. Using the menu is able to make the projector display the images stored in an SD memory card or a USB memory, and realizes a presentation without a PC. Use the ▲/▼/◀/▶ buttons to select an item, and the ► or ENTER button to perform the item. • While displaying the image, to press the MENU button displays the PC-LESS PRESENTATION menu.</p>					
	<p><b>THUMBNAIL</b></p>	<p>Use the ▲/▼/◀/▶ buttons to select an image, and press the ENTER or INPUT button to display the image.</p>				
	<p><b>SLIDE SHOW</b></p>	<p>Slide show will start when you press the ENTER or ► button.</p>				

(continued on next page)



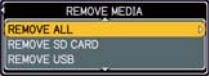

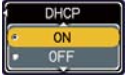



MIU menu (continued)

Item	Description	
<p><b>PC-LESS PRESENTATION</b> (continued)</p>	<p><b>DIRECTORY</b></p>	<p>Use the ▲/▼ buttons to select an image or a folder, and press the ENTER button to display the image or turn into the THUMBNAIL. To open or close the folder, press the ►/◀ buttons.</p> 
	<p><b>DISPLAY SIZE</b></p>	<p>Use the ▲/▼ buttons to set the display size.</p> 
	<p><b>KEY CONFIG.</b></p>	<p>Use the ▲/▼ buttons to select key configuration from the 2 patterns.</p> 
	<p><b>REMOVE MEDIA</b></p>	<p>Use the ▲/▼ buttons to select a remove mode, and then the ENTER or ► button is pressed so the menu will appear.</p> 
	<p>• Also these items can be set with Web Remote Control (Refer to Network Guide) except REMOVE MEDIA.</p>	
<p><b>SETUP</b></p>	<p>Selecting this item displays the MIU SETUP menu. Use the ▲/▼ buttons to select an item, and the ► or ENTER button on the remote control to perform the item.</p> 	
	<p><b>DHCP</b> (Dynamic Host Configuration Protocol)</p>	<p>Use the ▲/▼ buttons to turn DHCP on/off. ON ⇔ OFF Select OFF when the network does not have DHCP enabled.</p> <ul style="list-style-type: none"> <li>• When the “DHCP” setting changes to “ON”, it takes a little time to obtain IP address from DHCP server.</li> <li>• Auto IP function will be assigned an IP address if the projector could not obtain an IP address from server even if DHCP is “ON”.</li> </ul> 



(continued on next page)

## MIU menu (continued)

Item	Description	
<b>SETUP</b> (continued)	<b>IP ADDRESS</b>	<p>Use the ▲/▼/◀/▶ buttons to enter the IP ADDRESS. This function can only be used when DHCP is set to OFF.</p>  <ul style="list-style-type: none"> <li>• The IP ADDRESS is the number that identifies this projector on the network. You cannot have two devices with the same IP ADDRESS on the same network.</li> <li>• The IP ADDRESS "0.0.0.0" is prohibited.</li> </ul>
	<b>SUBNET MASK</b>	<p>Use the ▲/▼/◀/▶ buttons to enter the same SUBNET MASK used by your PC. This function can only be used when DHCP is set to OFF.</p>  <ul style="list-style-type: none"> <li>• The SUBNET MASK "0.0.0.0" is prohibited.</li> </ul>
	<b>DEFAULT GATEWAY</b>	<p>Use the ▲/▼/◀/▶ buttons to enter the DEFAULT GATEWAY (a node on a computer network that serves as an access point to another network) address. This function can only be used when DHCP is set to OFF.</p> 
	<b>DNS SERVER</b>	<p>Use the ▲/▼/◀/▶ buttons to input the DNS server address. The DNS server is a system to control domain names and IP addresses on the Network.</p> 
	<b>TIME DIFFERENCE</b>	<p>Use the ▲/▼ buttons to enter the TIME DIFFERENCE. Set the same TIME DIFFERENCE as the one set on your PC. If unsure, consult your IT manager. Use the ◀ button to return to the menu after setting the TIME DIFFERENCE.</p> 
	<b>DATE AND TIME</b>	<p>Use the ▲/▼/◀/▶ buttons to enter the Year (last two digits), Month, Date, Hour and Minute.</p>  <ul style="list-style-type: none"> <li>• The projector will override this setting and retrieve DATE AND TIME information from the Time server when SNTP is enabled. (📘 <b>Date/Time Settings of the User's Manual - Network Guide</b>)</li> </ul>

(continued on next page)

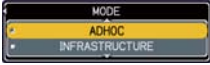
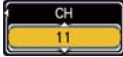
MIU menu (continued)

Item	Description
<p><b>SETUP</b> (continued)</p>	<p><b>MODE</b></p> <p>Use the ▲/▼ buttons to select the mode of the network communication system. Select it according to the setting of your PC.</p> <p>ADHOC ⇄ INFRASTRUCTURE</p> 
	<p><b>CH</b></p> <p>Use the ▲/▼ buttons to select the channel of the wireless LAN while using it. Select it according to the setting of your PC. The channels 1 to 11 are available.</p> <ul style="list-style-type: none"> <li>The available channels would be various depending on a country. In addition, wireless network card might be required due to the standard.</li> </ul> 
	<p><b>ENCRYPTION</b></p> <p>Use the ▲/▼ buttons to select the encryption method to be used.</p> <p>WPA2-PSK(AES) ← ⇄ WPA2-PSK(AES) ⇄ WPA-PSK(TKIP) ⇄ WEP 128bit ⇄ WEP 64bit ⇄ OFF</p> 
	<p><b>SSID</b></p> <p>Use the ▲/▼ buttons to select the SSID to display the SSID menu.</p>  <p><b>DEFAULT</b> Pressing the ► or ENTER button when one of the DEFAULT (#1~#4) is selected.</p> <p><b>CUSTOM</b> Press the ► or ENTER button when the # 5 CUSTOM is selected. The SSID #5 CUSTOM menu will be appeared.</p> <p>(1) The current SSID will be displayed on the first line. If not yet written, the line will be blank. Use the ▲/▼/◀/▶ buttons and the ENTER or INPUT button to select and enter characters. The RESET button can be used to erase 1 character at a time. Also if you move the cursor to DELETE or ALL CLEAR on screen and push the ENTER or INPUT button, 1 character or all characters will be erased. The SSID can be input up to 32 characters.</p>

(continued on next page)

MIU menu (continued)

Item	Description	
<p><b>SETUP</b> (continued)</p>	<p><b>SSID</b> (continued)</p>	<p>(2) To change an already inserted character, press the ▲/▼ button to move the cursor to one of the first 2 lines, and use the ◀ /▶ buttons to move the cursor on the character to be changed. After pressing the ENTER or INPUT button, the character is selected. Then, follow the same procedure as described at the item (1) above</p> <p>(3) To finish entering text, move the cursor to the SAVE on screen and press the ENTER or INPUT button. To revert to the previous SSID without saving changes, move the cursor to the CANCEL on screen and press the ENTER or INPUT button.</p> <div data-bbox="751 229 1021 703"> </div>
	<p><b>SPEED</b></p>	<p>Use the ▲/▼ buttons to select the transfer rate. (M : Mbps : Megabits per second)</p> <p>AUTO ⇄ 54M ⇄ 48M ⇄ 36M ⇄ 24M ⇄ 18M ⇕ 1M ⇄ 2M ⇄ 5.5M ⇄ 6M ⇄ 9M ⇄ 11M ⇄ 12M</p> <ul style="list-style-type: none"> <li>• The AUTO mode automatically selects the optimum rate.</li> <li>• Transfer rates may change due to the network situation.</li> </ul> <div data-bbox="904 879 1021 1139"> </div>
	<p><b>NETWORK MODE</b></p>	<p>Use the ▲/▼ buttons to select the network mode.</p> <p>WIRELESS ⇄ WIRED</p> <ul style="list-style-type: none"> <li>• The network mode will be initialized whenever the power is turned on with the power switch.</li> <li>• The WIRELESS will be enabled when the wireless network card is inserted.</li> <li>• The WIRED will be enabled when the wireless network card is not inserted.</li> </ul> <div data-bbox="882 1174 1031 1251"> </div>

(continued on next page)

**MIU menu (continued)**

Item	Description
<p><b>PROJECTOR NAME</b></p>	<p>(1) Use the ▲/▼ buttons on the MIU menu to select the PROJECTOR NAME menu and press the ► button. The PROJECTOR NAME dialog will be displayed.</p> <p>(2) The current PROJECTOR NAME will be displayed on the first 3 lines. If not yet written, the lines will be blank. Use the ▲/▼/◀/► buttons and the ENTER or INPUT button to select and enter characters. The RESET button can be used to erase 1 character at a time. Also if you move the cursor to DELETE or ALL CLEAR on screen and push the ENTER or INPUT button, 1 character or all characters will be erased. The PROJECTOR NAME can be input up to 64.</p>
	<p>(3) To change an already inserted character, press the ▲/▼ button to move the cursor to one of the first 3 lines, and use the ◀/► buttons to move the cursor on the character to be changed. After pressing the ENTER or INPUT button, the character is selected. Then, follow the same procedure as described at the item (2) above.</p>
	<p>(4) To finish entering text, move the cursor to the SAVE on screen and press the ENTER or INPUT button. To revert to the previous PROJECTOR NAME without saving changes, move the cursor to the CANCEL on screen and press the ENTER or INPUT button.</p>

(continued on next page)

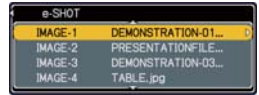

**MIU menu (continued)**

Item	Description
<p>e-SHOT</p>	<p>Selecting this item displays the e-SHOT menu.                      Insert the SD memory card or USB memory into the projector before you use the e-SHOT function. (61)                      The application software “PJTransfer” is required to store image(s) into the projector.</p> <p>Use the ▲/▼ buttons to select an item which is a still image by the e-SHOT (e-SHOT (Still Image Transfer) Display of the User’s Manual - Network Guide) and the ► or ENTER button to display the image.</p> <ul style="list-style-type: none"> <li>• The item without image stored cannot be selected.</li> <li>• The image names are each displayed in 16 characters or less.</li> </ul> <p><b>To switch the image displayed</b>                      Use the ▲/▼ buttons.</p> <p><b>To return to the menu</b>                      Press the ◀ or ESC button on the remote control.</p> <p><b>To erase the image displayed and its source file in the SD memory card or USB memory</b></p> <p>(1) Press the RESET button on the remote control while displaying an image to display the e-SHOT - RESET menu.</p> <p>(2) Press the ENTER button on the remote control or the INPUT button on the projector to perform to erase.                      To stop erasing, press the ESC button on the remote control or the ◀ button on the projector.</p>

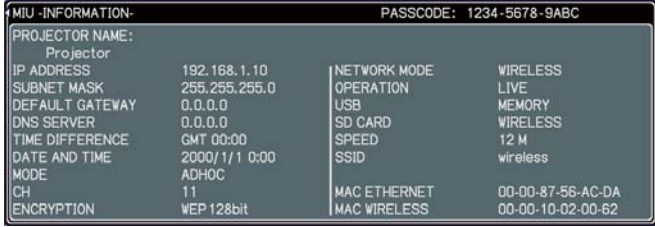

(continued on next page)

MIU menu (continued)

Item	Description
<p><b>INFORMATION</b></p>	<p>Selecting this item displays the MIU-INFORMATION- dialog for confirming the network settings.</p>  <ul style="list-style-type: none"> <li>• The PROJECTOR NAME is displayed.</li> <li>• Nothing (blank) is shown in the “PROJECTOR NAME” and “SSID” field until you setup those items. (☞ 58, 59, 60)</li> <li>• When the voltage level of the battery for the built in clock decreases, the set time may become incorrect even though accurate date and time are input. Replace the battery suitably. (☞ 68)</li> <li>• MAC wireless will not be displayed when the NETWORK MODE is set to the WIRED even if the wireless network card is mounted.</li> <li>• IP ADDRESS, SUBNET MASK and DEFAULT GATEWAY indicate “0.0.0.0” in the following condition.             <ol style="list-style-type: none"> <li>(1) The NETWORK MODE is set to the WIRELESS and the wireless network card is not mounted.</li> <li>(2) DHCP is ON and the projector does not get address from DHCP server.</li> </ol> </li> <li>• Nothing (blank) is shown in the “CH”, “SPEED” and “MAC WIRELESS” field in case of either no wireless network card is inserted or “WIRED” mode is selected at NETWORK MODE, or both.</li> <li>• The actual performance and setting will be shown in the “CH” and “SPEED” field, instead of the setting value in the SETUP menu.</li> </ul>
<p><b>SERVICE</b></p>	<p><b>MIU RESTART</b> Use the ▲ button to restart the network communication. The network communication will be cut off once and restarted.</p>  <p>EXECUTE ⇄ CANCEL</p> <ul style="list-style-type: none"> <li>• After selecting the EXECUTE, the MIU menu may not be controlled approximately 20 seconds.</li> <li>• If DHCP is ON, IP address may be changed.</li> </ul>

## C.C. (Closed Caption) menu

The closed caption setting can be changed through C.C. menu in the advance menu. Please select the item that you will change using ▲/▼ cursor buttons.

• The C.C. (Closed Caption) is the function that displays a transcript or dialog of the audio portion of a video, files or other presentation or other relevant sounds. It is required to have NTSC format video source supporting C.C. feature to utilize this function.



Item	Description
<p><b>DISPLAY</b></p>	<p>Select Closed Caption DISPLAY setting from following options using ▲/▼ buttons.</p> <p>TURN OFF ⇄ TURN ON ⇄ AUTO</p> <p style="text-align: center;">↑—————↓</p> <p>TURN OFF: Closed Caption is OFF            TURN ON: Closed Caption is ON            AUTO: Closed Caption automatically displays when the volume is muted.</p> <ul style="list-style-type: none"> <li>• The caption is not displayed when the OSD menu is active.</li> <li>• The Closed Caption is the function to display the dialogue, narration, and / or sound effects of a television program or other video sources. The Closed Caption availability is depending upon broadcaster and/or content.</li> <li>• The caption is only available if the video source is NTSC format and the video format selection is AUTO or NTSC on the INPUT menu.</li> <li>• It may not work properly, depending on equipment or signal source. In this case, please turn off the Closed Caption.</li> </ul>
<p><b>MODE</b></p>	<p>Select Closed Caption MODE setting from following options using ▲/▼ buttons.</p> <p>CAPTIONS ⇄ TEXT</p> <p>CAPTIONS: Display Closed Caption            TEXT: Display Text data, which is for additional information such as news reports or a TV program guide. The information covers the entire screen. Not all of the C.C. program has Text information.</p>
<p><b>CHANNEL</b></p>	<p>Select Closed Caption CHANNEL from following options using ▲/▼ buttons.</p> <p>1 ⇄ 2 ⇄ 3 ⇄ 4</p> <p style="text-align: center;">↑—————↓</p> <p>1: Channel 1, primary channel / language            2: Channel 2            3: Channel 3            4: Channel 4</p> <p>The channel data may vary, depending on the content. Some channel might be used for secondary language or empty.</p>





Maintenance

## Replacing the lamp

A lamp has finite product life. Using the lamp for long periods of time could cause the pictures darker or the color tone poor. Note that each lamp has a different lifetime, and some may burst or burn out soon after you start using them. Preparation of a new lamp and early replacement are recommended. To prepare a new lamp, contact to your dealer and tell the lamp type number.

Type number : DT00841

### Replacing the lamp

1. Turn the projector off, and unplug the power cord. Allow the projector to cool for at least 45 minutes.
2. Prepare a new lamp. If the projector is mounted on a ceiling, or if the lamp has broken, also ask the dealer to replace the lamp.

In case of replacement by yourself, follow the following procedure.

3. Loosen the screw (marked by arrow) of the lamp cover and then slide the lamp cover to the side to remove it.
4. Loosen the 2 screws (marked by arrow) of the lamp, and slowly pick up the lamp by the handles.
5. Insert the new lamp, and retighten firmly the 2 screws of the lamp that are loosened in the previous process to lock it in place.
6. Slide the lamp cover back in place and firmly fasten the screw of the lamp cover.
7. Turn the projector on and reset the lamp time using the LAMP TIME item in the OPTION menu.
  - (1) Press the MENU button to display a menu.
  - (2) Point at the Go to Advanced Menu ... in the menu using the ▼/▲ button, then press the ► button.
  - (3) Point at the OPTION in the left column of the menu using the ▼/▲ button, then press the ► button.
  - (4) Point at the LAMP TIME using the ▼/▲ button, then press the ► button. A dialog will appear.
  - (5) Press the ▲ button to select RESET on the dialog. It performs resetting the lamp time.

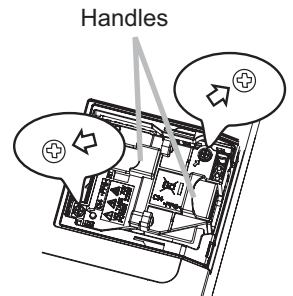
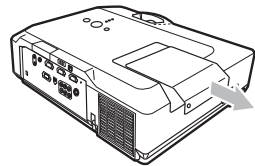
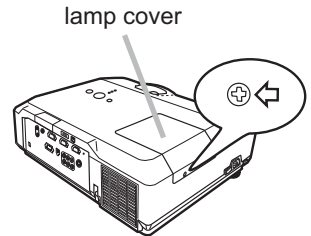

**⚠ CAUTION** ► Do not touch any inner space of the projector, while the lamp is taken out.

**NOTE** • Please reset the lamp time only when you have replaced the lamp, for a suitable indication about the lamp.

## Replacing the lamp (continued)

### Lamp warning

 **HIGH VOLTAGE**     **HIGH TEMPERATURE**     **HIGH PRESSURE**

**WARNING** ▶ The projector uses a high-pressure mercury glass lamp. The lamp can break with a loud bang, or burn out, if jolted or scratched, handled while hot, or worn over time. Note that each lamp has a different lifetime, and some may burst or burn out soon after you start using them. In addition, when the bulb bursts, it is possible for shards of glass to fly into the lamp housing, and for gas containing mercury to escape from the projector's vent holes.

▶ **About disposal of a lamp:** This product contains a mercury lamp; do not put it in a trash. Dispose of it in accordance with environmental laws.

- For lamp recycling, go to [www.lamprecycle.org](http://www.lamprecycle.org) (in the US).
- For product disposal, contact your local government agency or [www.eiae.org](http://www.eiae.org) (in the US) or [www.epsc.ca](http://www.epsc.ca) (in Canada).

For more information, call your dealer.



Disconnect  
the plug  
from the  
power  
outlet

- If the lamp should break (it will make a loud bang when it does), unplug the power cord from the outlet, and make sure to request a replacement lamp from your local dealer. Note that shards of glass could damage the projector's internals, or cause injury during handling, so please do not try to clean the projector or replace the lamp yourself.
- If the lamp should break (it will make a loud bang when it does), ventilate the room well, and make sure not to breathe the gas that comes out of the projector vents, or get it in your eyes or mouth.
- Before replacing the lamp, turn the projector off and unplug the power cord, then wait at least 45 minutes for the lamp to cool sufficiently. Handling the lamp while hot can cause burns, as well as damaging the lamp.



- Never unscrew except the appointed (marked by an arrow) screws.
- Do not open the lamp cover while the projector is suspended from a ceiling. This is dangerous, since if the lamp's bulb has broken, the shards will fall out when the cover is opened. In addition, working in high places is dangerous, so ask your local dealer to have the lamp replaced even if the bulb is not broken.
- Do not use the projector with the lamp cover removed. At the lamp replacing, make sure that the screws are screwed in firmly. Loose screws could result in damage or injury.



- Use only the lamp of the specified type.
- If the lamp breaks soon after the first time it is used, it is possible that there are electrical problems elsewhere besides the lamp. If this happens, contact to your local dealer or a service representative.
- Handle with care: jolting or scratching could cause the lamp bulb to burst during use.
- Using the lamp for long periods of time, could cause it dark, not to light up or to burst. When the pictures appear dark, or when the color tone is poor, please replace the lamp as soon as possible. Do not use old (used) lamps; this is a cause of breakage.

## Cleaning and replacing the air filter

Please check and clean the air filter periodically. When the indicators or a message prompts you to clean the air filter, comply with it as soon as possible. Replace the air filter when it is damaged or too soiled. To prepare a new air filter, contact to your dealer and tell the air filter type number.

**Type number : MU04951**

When you replace the lamp, please replace the air filter. An air filter of specified type will come together with a replacement lamp for this projector.

1. Turn the projector off, and unplug the power cord.  
• Allow the projector to sufficiently cool down.
2. Use a vacuum cleaner on and around the filter cover.
3. Pull the filter cover knobs while lifting it. The filter unit which consists of the filter' cover, air filter and filter frame will come off.
4. Use a vacuum cleaner for the filter vent of the projector and the filter frame side of the filter unit. If the air filter is damaged or too soiled, replace it according to the following procedure number 5 to 7. Otherwise, please jump to the procedure number 8.
5. Pull the filter frame's knob up while holding the filter cover. The filter frame will come off and the air filter will appear.
6. Replace the air filter with new one.
7. Put the filter frame back.
8. Put the filter unit back into the projector.

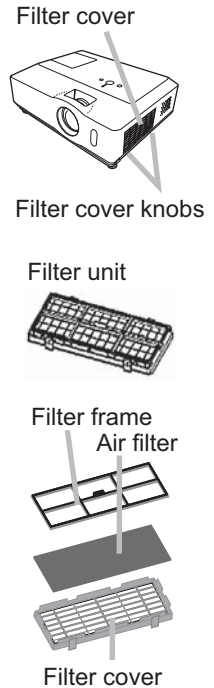

(continued on next page)

**Cleaning and replacing the air filter (continued)**

9. Turn the projector on and reset the filter time using the FILTER TIME item in the EASY MENU.
- (1) Press the MENU button to display a menu.
  - (2) Point at the FILTER TIME using the ▼/▲ button, then press the ► button. A dialog will appear.
  - (3) Press the ▲ button to select RESET on the dialog. It performs resetting the filter time.

**⚠ WARNING** ► Before taking care of the air filter, make sure the power switch is off and the power cable is not plugged in, then allow the projector to cool sufficiently. Taking care of the air filter in a high temperature state of the projector could cause an electric shock, a burn or malfunction to the projector.

► Use only the air filter of the specified type. Do not use the projector without the air filter or the filter cover. It could result in a fire or malfunction to the projector.

► Clean the air filter periodically. If the air filter becomes clogged by dust or the like, internal temperatures rise and could cause a fire, a burn or malfunction to the projector.

**NOTE** • Please replace the air filter when it is damaged or too soiled.

- When you replace the projection lamp, please replace the air filter. An air filter of specified type will come together with a replacement lamp for this projector.
- Please reset the filter time only when you have cleaned or replaced the air filter, for a suitable indication about the air filter.
- The projector may display the message such as “CHECK THE AIR FLOW” or turn off the projector, to prevent the internal heat level rising.

## Replacing the internal clock battery

Consumption of the battery makes the internal clock not to work correctly. When the internal clock is wrong or it has stopped, please replace the battery according to the following procedures.

1. Turn the projector off, and unplug the power cord. Allow the projector to cool sufficiently.
2. After making sure that the projector has cooled adequately, pull the SD card slot cover forward, pushing slightly its edge up, and remove it from the projector.
3. Remove the battery case. Hold the battery case gutter by finger nail or other thing and pull out the battery case slowly from the battery slot. While the projector is installed upside down, such as a ceiling mount, please remember the battery will drop down as soon as pulling the battery case out.
4. Take the old battery out from the battery case.
5. Replace a new battery. Replace battery with **HITACHI MAXELL, Part No.CR2032** only. Use of another battery may present a risk of fire or explosion. Put a new battery into battery case. Please make sure that the + is facing upward. Insert the battery case slowly into the battery slot until you hear the snap.
6. Close the slot cover. Replace the SD card slot cover by reversing the procedure used when removing the cover.

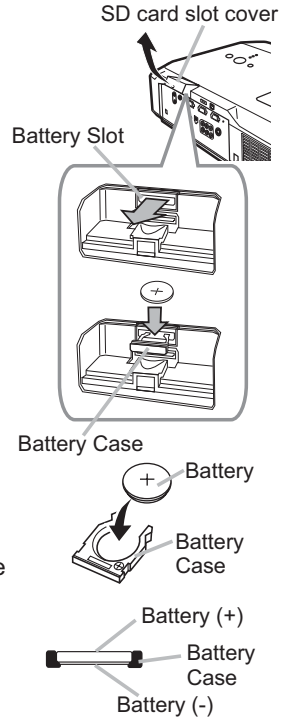

**⚠ WARNING** ▶ Always handle the batteries with care and use them only as directed. Battery may explode if mistreated. Do not recharge, disassemble or dispose of in fire. And also improper use may result in cracking or leakage, which could result in fire, injury and/or pollution of the surrounding environment.

- Be sure to use only the batteries specified.
- Make sure the plus and minus terminals are correctly aligned when loading a battery.
- Keep a battery away from children and pets. If swallowed consult a physician immediately for emergency treatment.
- Do not short circuit or solder a battery.
- Do not allow a battery in a fire or water. Keep batteries in a dark, cool and dry place.
- If you observe battery leakage, wipe out the leakage and then replace a battery. If the leakage adheres to your body or clothes, rinse well with water immediately.
- Obey the local laws on disposing the battery.

**NOTE** • The internal clock's time will be reset when the battery is removed. Please reconfigure the time via the menu or a web browser after replacing the battery.

[📖 Date/Time Settings in the User's Manual \(detailed\) - Network Guide](#)

## Other care

### Inside of the projector

In order to ensure the safe use of your projector, please have it cleaned and inspected by your dealer about once every year.

### Caring for the lens

If the lens is flawed, soiled or fogged, it could cause deterioration of display quality. Please take care of the lens, being cautious of handling.

1. Turn the projector off, and unplug the power cord. Allow the projector to cool sufficiently.
2. After making sure that the projector is cool adequately, lightly wipe the lens with a commercially available lens-cleaning wipe. Do not touch the lens directly with your hand.

### Caring for the cabinet and remote control

Incorrect care could have adverse influence such as discoloration, peeling paint, etc.

1. Turn the projector off, and unplug the power cord. Allow the projector to cool sufficiently.
2. After making sure that the projector is cool adequately, lightly wipe with gauze or a soft cloth.  
If the projector is extremely dirty, dip soft cloth in water or a neutral cleaner diluted in water, and wipe lightly after wringing well. Then, wipe lightly with a soft, dry cloth.

**⚠ WARNING** ► Before caring, make sure the power cord is not plugged in, and then allow the projector to cool sufficiently. The care in a high temperature state of the projector could cause a burn and/or malfunction to the projector.

► Never try to care for the inside of the projector personally. Doing is so dangerous.

► Avoid wetting the projector or inserting liquids in the projector. It could result in a fire, an electric shock, and/or malfunction to the projector.

- Do not put anything containing water, cleaners or chemicals near the projector.
- Do not use aerosols or sprays.

**⚠ CAUTION** ► Please take right care of the projector according to the following. Incorrect care could cause not only an injury but adverse influence such as discoloration, peeling paint, etc.

- Do not use cleaners or chemicals other than those specified in this manual.
- Do not polish or wipe with hard objects.

## Troubleshooting

If an abnormal operation should occur, stop using the projector immediately.

**⚠ WARNING** ▶ Never use the projector if abnormal operations such as smoke, strange odor, excessive sound, damaged casing or elements or cables, penetration of liquids or foreign matter, etc. should occur. In such cases, immediately turn off the power switch and then disconnect the power plug from the power outlet. After making sure that the smoke or odor has stopped, contact to your dealer or service company.

Otherwise if a problem occurs with the projector, the following checks and measures are recommended before requesting repair.

If this does not resolve the problem, please contact your dealer or service company. They will tell you what warranty condition is applied.

### Related messages

When some message appears, check and cope with it according to the following table. Although these messages will be automatically disappeared around several minutes, it will be reappeared every time the power is turned on.

Message	Description
<p style="text-align: center;">NO INPUT IS DETECTED ***</p>	<p><b>There is no input signal.</b> Please confirm the signal input connection, and the status of the signal source.</p>
<p style="text-align: center;">SYNC IS OUT OF RANGE *** [fH] **kHz [fV] **Hz</p>	<p><b>The horizontal or vertical frequency of the input signal is not within the specified range.</b> Please confirm the specs for your projector or the signal source specs.</p>
<p style="text-align: center;"><b>CHECK THE AIR FLOW</b></p>	<p><b>The internal temperature is rising.</b> Please turn the power off, and allow the projector to cool down at least 20 minutes. After having confirmed the following items, please turn the power ON again.</p> <ul style="list-style-type: none"> <li>• Is there blockage of the air passage aperture?</li> <li>• Is the air filter dirty?</li> <li>• Does the peripheral temperature exceed 35°C?</li> </ul> <p>If the same indication is displayed after the remedy, please set FAN SPEED of the SERVICE item in the OPTION menu to HIGH.</p>
<p style="text-align: center;"><b>REMINDER</b> *** HRS PASSED AFTER THE LAST FILTER CHECK. FILTER MAINTENANCE IS ESSENTIAL TO REMOVE WARNING MESSAGE. RESET FILTER TIMER. SEE MANUAL FURTHER INFO.</p>	<p><b>A note of precaution when cleaning the air filter.</b> Please immediately turn the power off, and clean or change the air filter referring to the “Air filter” section of this manual. After you have cleaned or changed the air filter, please be sure to reset the filter timer (66).</p>

## Regarding the indicator lamps

When operation of the LAMP, TEMP and POWER indicators differs from usual, check and cope with it according to the following table.

POWER indicator	LAMP indicator	TEMP indicator	Description
Lighting In <b>Orange</b>	Turned <b>off</b>	Turned <b>off</b>	<b>The projector is in a standby state.</b> Please refer to the section "Power on/off".
<i>Blinking</i> In <b>Green</b>	Turned <b>off</b>	Turned <b>off</b>	<b>The projector is warming up.</b> Please wait.
Lighting In <b>Green</b>	Turned <b>off</b>	Turned <b>off</b>	<b>The projector is in an on state.</b> Ordinary operations may be performed.
<i>Blinking</i> In <b>Orange</b>	Turned <b>off</b>	Turned <b>off</b>	<b>The projector is cooling down.</b> Please wait.
<i>Blinking</i> In <b>Red</b>	(discre- tionary)	(discre- tionary)	<b>The projector is cooling down. A certain error has been detected.</b> Please wait until POWER indicator finishes blinking, and then perform the proper measure using the item descriptions below.
<i>Blinking</i> In <b>Red</b> or Lighting In <b>Red</b>	Lighting In <b>Red</b>	Turned <b>off</b>	<b>The lamp does not light, and there is a possibility that interior portion has become heated.</b> Please turn the power off, and allow the projector to cool down at least 20 minutes. After the projector has sufficiently cooled down, please make confirmation of the following items, and then turn the power on again. • Is there blockage of the air passage aperture? • Is the air filter dirty? • Does the peripheral temperature exceed 35°C? If the same indication is displayed after the remedy, please change the lamp referring to the section "Lamp".
<i>Blinking</i> In <b>Red</b> or Lighting In <b>Red</b>	<i>Blinking</i> In <b>Red</b>	Turned <b>off</b>	<b>The lamp cover has not been properly fixed.</b> Please turn the power off, and allow the projector to cool down at least 45 minutes. After the projector has sufficiently cooled down, please make confirmation of the attachment state of the lamp cover. After performing any needed maintenance, turn the power on again. If the same indication is displayed after the remedy, please contact your dealer or service company.
<i>Blinking</i> In <b>Red</b> or Lighting In <b>Red</b>	Turned <b>off</b>	<i>Blinking</i> In <b>Red</b>	<b>The cooling fan is not operating.</b> Please turn the power off, and allow the projector to cool down at least 20 minutes. After the projector has sufficiently cooled down, please make confirmation that no foreign matter has become caught in the fan, etc., and then turn the power on again. If the same indication is displayed after the remedy, please contact your dealer or service company.

(Continued on next page)



Regarding the indicator lamps (continued)

POWER indicator	LAMP indicator	TEMP indicator	Description
Blinking In <b>Red</b> or Lighting In <b>Red</b>	Turned off	Lighting In <b>Red</b>	<p><b>There is a possibility that the interior portion has become heated.</b></p> <p>Please turn the power off, and allow the projector to cool down at least 20 minutes. After the projector has sufficiently cooled down, please make confirmation of the following items, and then turn the power on again.</p> <ul style="list-style-type: none"> <li>• Is there blockage of the air passage aperture?</li> <li>• Is the air filter dirty?</li> <li>• Does the peripheral temperature exceed 35°C?</li> </ul> <p>If the same indication is displayed after the remedy, please set FAN SPEED of SERVICE item in OPTION menu to HIGH (M45).</p>
Lighting In <b>Green</b>	Simultaneous blinking in <b>Red</b>		<p><b>It is time to clean the air filter.</b></p> <p>Please immediately turn the power off, and clean or change the air filter referring to the section “Air Filter”. After cleaning or changing the air filter, please be sure to reset the filter timer. After the remedy, reset the power to ON.</p>
Lighting In <b>Green</b>	Alternative blinking in <b>Red</b>		<p><b>There is a possibility that the interior portion has become overcooled.</b></p> <p>Please use the unit within the usage temperature parameters (5°C to 35°C). After the treatment, reset the power to ON.</p>
Blinking in <b>Green</b> for approx. 3 seconds	Turned off	Turned off	<p><b>At least 1 Power ON schedule is saved to the projector.</b></p> <p>Please refer to “Schedule Settings” section of User’s Manual-Network Guide.</p>

**NOTE** • When the interior portion has become overheated, for safety purposes, the projector is automatically shut down, and the indicator lamps may also be turned off. In such a case, disconnect the power cord, and wait at least 45 minutes. After the projector has sufficiently cooled down, please make confirmation of the attachment state of the lamp and lamp cover, and then turn the power on again.

**Shutting the projector down**

Only when the projector can not be turned off by usual procedure (M16), please push the shutdown switch using a pin or similar, and disconnect the power plug from the power outlet. Before turning it on again, wait at least 10 minutes to make the projector cool down enough.

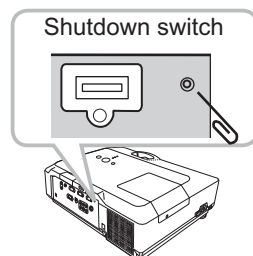

**Resetting all settings**

When it is hard to correct some wrong settings, the FACTORY RESET function of SERVICE item in OPTION menu (M46) can reset all settings(except LANGUAGE, FILTER TIME, LAMP TIME, FILTER MESSAGE, MIU settings and etc.) to the factory default.

## Phenomena that may be easy to be mistaken for machine defects

About the phenomenon confused with a machine defect, check and cope with it according to the following table.

Phenomenon	Cases not involving a machine defect	Reference page
Power does not come on.	<b>The electrical power cord is not plugged in.</b> Correctly connect the power cord.	13
	<b>The main power source has been interrupted during operation such as by a power outage (blackout), etc.</b> Please disconnect the power plug from the power outlet, and allow the projector to cool down at least 10 minutes, then turn the power on again.	13, 16
	<b>Either there is no lamp and/or lamp cover, or either of these has not been properly fixed.</b> Please turn the power off and disconnect the power plug from the power outlet, and allow the projector to cool down at least 45 minutes. After the projector has sufficiently cooled down, please make confirmation of the attachment state of the lamp and lamp cover, and then turn the power on again.	64, 65
Neither sounds nor pictures are outputted.	<b>The signal cables are not correctly connected.</b> Correctly connect the connection cables.	9
	<b>Signal source does not correctly work.</b> Correctly set up the signal source device by referring to the manual of the source device.	—
	<b>The input changeover settings are mismatched.</b> Select the input signal, and correct the settings.	17, 18
	<b>The BLANK function for pictures and the MUTE function for sounds are working.</b> AV Mute may be active. Refer to the item “Sound does not come out” and “No pictures are displayed” on the next page to turn off the MUTE and BLANK functions.	17, 22

(Continued on next page)

**Phenomena that may be easy to be mistaken for machine defects (continued)**

Phenomenon	Cases not involving a machine defect	Reference page
Sound does not come out.	<p><b>The signal cables are not correctly connected.</b> Correctly connect the audio cables.</p>	9
	<p><b>The MUTE function is working.</b> Restore the sound pressing MUTE or VOLUME button on the remote control.</p>	17
	<p><b>The volume is adjusted to an extremely low level.</b> Adjust the volume to a higher level using the menu function or the remote control.</p>	17
	<p><b>The AUDIO/SPEAKER setting is not correct.</b> Correctly set the AUDIO/SPEAKER in SETUP menu.</p>	36, 37
No pictures are displayed.	<p><b>The lens cover is attached.</b> Remove the lens cover.</p>	4, 16
	<p><b>The signal cables are not correctly connected.</b> Correctly connect the connection cables.</p>	9
	<p><b>The brightness is adjusted to an extremely low level.</b> Adjust BRIGHTNESS to a higher level using the menu function.</p>	26, 27
	<p><b>The computer cannot detect the projector as a plug and play monitor.</b> Make sure that the computer can detect a plug and play monitor using another plug and play monitor.</p>	11
	<p><b>The BLANK screen is displayed.</b> Press BLANK button on the remote control.</p>	22

(Continued on next page)

**Phenomena that may be easy to be mistaken for machine defects (continued)**

Phenomenon	Cases not involving a machine defect	Reference page
Video screen display freezes.	<b>The FREEZE function is working.</b> Press FREEZE button to restore the screen to normal.	22
Colors have a faded- out appearance, or Color tone is poor.	<b>Color settings are not correctly adjusted.</b> Perform picture adjustments by changing the COLOR TEMP, COLOR, TINT and/or COLOR SPACE settings, using the menu functions.	26, 28, 32
	<b>COLOR SPACE setting is not suitable.</b> Change the COLOR SPACE setting to AUTO, RGB, SMPTE240, REC709 or REC601.	32
Pictures appear dark.	<b>The brightness and/or contrast are adjusted to an extremely low level.</b> Adjust BRIGHTNESS and/or CONTRAST settings to a higher level using the menu function.	26, 27
	<b>The WHISPER function is working.</b> Select NORMAL for WHISPER item in the SETUP menu.	26, 36
	<b>The lamp is approaching the end of its product lifetime.</b> Replace the lamp.	64, 65
Pictures appear blurry.	<b>Either the focus and/or horizontal phase settings are not properly adjusted.</b> Adjust the focus using the focus ring, and/or H PHASE using the menu function.	19, 31
	<b>The lens is dirty or misty.</b> Clean the lens referring to the section "Caring for the lens".	68

**NOTE** • Although bright spots or dark spots may appear on the screen, this is a unique characteristic of liquid crystal displays, and it does not constitute or imply a machine defect.

Specifications

**Specifications**

Item	Specifications		
Product name	Liquid crystal projector		
Liquid Crystal Panel	Panel size 1.6 cm (0.63 type)		
	Drive system TFT active matrix		
	Pixels 786,432 pixels (1024 horizontal x 768 vertical)		
Lens	Zoom lens F=1.7 ~ 1.9 f = 19.5~ 23.4 mm (approximately)		
Lamp	220W UHB		
Audio output	7 W		
Power supply	AC 100-120V/3.8A, AC220-240V/1.6A		
Power consumption	350W		
Temperature range	5 ~ 35°C (Operating)		
Size	340 (W) x 117 (H) x 270 (D) mm *Excluding protrusions Please refer to the following figure.		
Weight (mass)	approx. 4.0 kg		
Ports	<table border="0"> <tr> <td style="vertical-align: top;"> <p><b>Computer input port</b> COMPUTER IN1 .....D-sub 15 pin mini x1 COMPUTER IN2 .....D-sub 15 pin mini x1</p> <p><b>Computer output port</b> MONITOR OUT .....D-sub 15 pin mini x1</p> <p><b>Video input port</b> COMPONENT (Y, Cb/Pb, Cr/Pr) ..... RCA x3 S-VIDEO ..... mini DIN 4 pin x1 VIDEO ..... RCA x1</p> </td> <td style="vertical-align: top; padding-left: 20px;"> <p><b>Audio input/output port</b> AUDIO IN1 ..... Stereo mini x1 AUDIO IN2 ..... Stereo mini x1 AUDIO IN3 ..... RCA x2 AUDIO OUT ..... Stereo mini x1</p> <p><b>Others</b> USB STORAGE ..... USB-A x1 SD card ..... SD card slot x1 USB ..... USB-B x1 CONTROL ..... D-sub 9 pin x1 LAN ..... RJ45 x1</p> </td> </tr> </table>	<p><b>Computer input port</b> COMPUTER IN1 .....D-sub 15 pin mini x1 COMPUTER IN2 .....D-sub 15 pin mini x1</p> <p><b>Computer output port</b> MONITOR OUT .....D-sub 15 pin mini x1</p> <p><b>Video input port</b> COMPONENT (Y, Cb/Pb, Cr/Pr) ..... RCA x3 S-VIDEO ..... mini DIN 4 pin x1 VIDEO ..... RCA x1</p>	<p><b>Audio input/output port</b> AUDIO IN1 ..... Stereo mini x1 AUDIO IN2 ..... Stereo mini x1 AUDIO IN3 ..... RCA x2 AUDIO OUT ..... Stereo mini x1</p> <p><b>Others</b> USB STORAGE ..... USB-A x1 SD card ..... SD card slot x1 USB ..... USB-B x1 CONTROL ..... D-sub 9 pin x1 LAN ..... RJ45 x1</p>
<p><b>Computer input port</b> COMPUTER IN1 .....D-sub 15 pin mini x1 COMPUTER IN2 .....D-sub 15 pin mini x1</p> <p><b>Computer output port</b> MONITOR OUT .....D-sub 15 pin mini x1</p> <p><b>Video input port</b> COMPONENT (Y, Cb/Pb, Cr/Pr) ..... RCA x3 S-VIDEO ..... mini DIN 4 pin x1 VIDEO ..... RCA x1</p>	<p><b>Audio input/output port</b> AUDIO IN1 ..... Stereo mini x1 AUDIO IN2 ..... Stereo mini x1 AUDIO IN3 ..... RCA x2 AUDIO OUT ..... Stereo mini x1</p> <p><b>Others</b> USB STORAGE ..... USB-A x1 SD card ..... SD card slot x1 USB ..... USB-B x1 CONTROL ..... D-sub 9 pin x1 LAN ..... RJ45 x1</p>		
Optional parts	<p><b>Lamp:</b> DT00841  <b>Air filter:</b> MU04951  <b>Wireless network card:</b> VA08331</p> <p>*For more information, contact to your dealer.</p>		

## Specifications (continued)

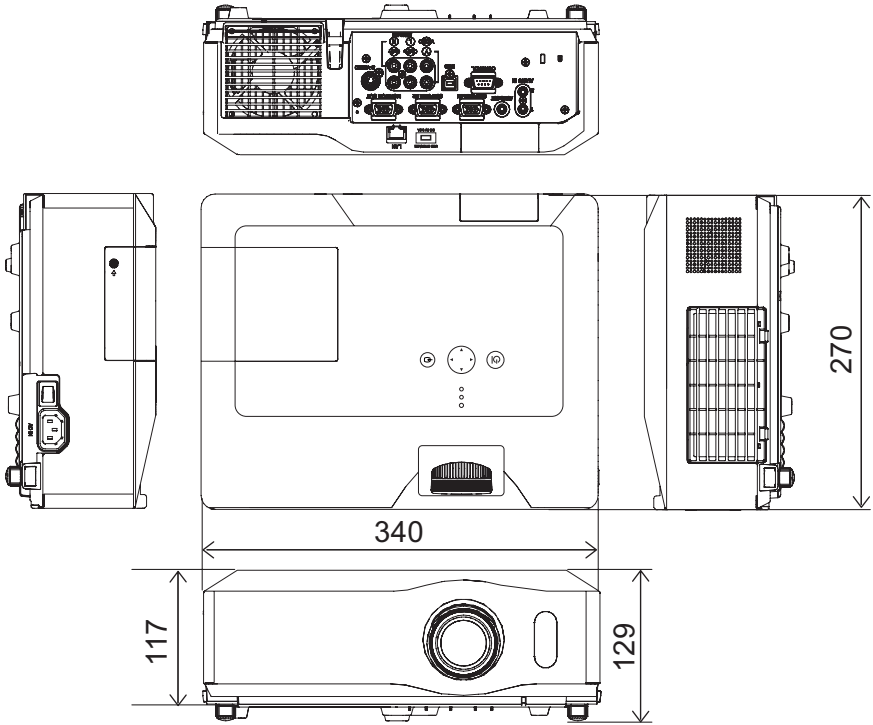

[unit: mm]

# Projector

## CP-X308

### User's Manual (detailed) Network Guide

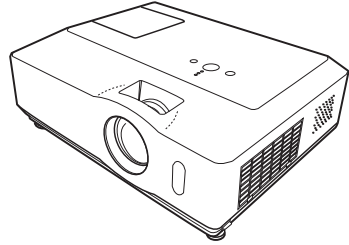

**Thank you for purchasing this projector.**

This projector has the network function that brings you the following main features.

✓ **Live Mode**

This projector can project your PC images on screen through wireless or wired network, which can erase a signal cable from your desk.

✓ **Quick connection to your network**

No expert knowledge is required any more. Various options for network setting give you a quick and simple connection to the network.

✓ **Web control**

The projector can be controlled and monitored by a web browser software on your PC, which can help you to setup and maintain the projector.

✓ **PC-LESS Presentation**

This projector can project images stored in an SD memory or a USB memory on screen, which allow you not to bring your PC with you.

This manual is only intended to explain Network functions only.

For safety, operations or any other issues, refer to the Safety Guide and User's Manual (concise and detailed).

**⚠ WARNING** ▶ Before using this product, be sure to read all manuals for this product.

After reading them, store them in a safe place for future reference.

**NOTE** • The information in this manual is subject to change without notice.

- The manufacturer assumes no responsibility for any errors that may appear in this manual.
- The reproduction, transfer or copy of all or any part of this document is not permitted without express written consent.

#### Trademark acknowledgment

• Windows is a registered trademark of Microsoft Corporation.

All other trademarks are the properties of their respective owners.

Content

<b>About this manual</b> . . . . .	<b>1</b>		
<b>Content</b> . . . . .	<b>2</b>		
<b>Caution</b> . . . . .	<b>3</b>		
<b>1. Main functions</b> . . . . .	<b>5</b>		
1.1 Live Mode (Project images from PC) . . . . .	5		
1.2 Quick connection to your network . . . . .	6		
1.3 Configuring and controlling via a web browser . . . . .	7		
1.4 PC-LESS Presentation (Display the images stored in SD memory card/USB memory) . . . . .	8		
<b>2. Equipment connection and network setting</b> . . . . .	<b>10</b>		
2.1 Required equipment preparation . . . . .	10		
2.2 Quick connection . . . . .	10		
2.3 Manual network connection setting - Wired LAN - . . . . .	11		
2.3.1 Equipments connection . . . . .	11		
2.3.2 Network settings . . . . .	11		
2.3.3 "Internet Option" setting . . . . .	14		
2.3.4 Check connection . . . . .	15		
2.4 Manual network connection setting -Wireless LAN . . . . .	16		
2.4.1 Preparation for wireless LAN connection . . . . .	16		
2.4.2 Wireless LAN connection set up . . . . .	17		
<b>3. Using the Live Mode</b> . . . . .	<b>20</b>		
3.1 Outline of the Live Mode . . . . .	21		
3.1.1 Display mode . . . . .	21		
3.1.2 Presenter mode . . . . .	22		
3.1.3 Display User Name . . . . .	22		
3.2 Install "Live Viewer 3" . . . . .	23		
3.2.1 Minimum PC hardware and software requirement . . . . .	23		
3.2.2 Software Installation Procedure . . . . .	24		
3.2.3 Version of the "Live Viewer" software . . . . .	25		
3.3 Quick connection to the network . . . . .	26		
3.3.1 Starting the "Live Viewer 3" . . . . .	26		
3.3.2 Selecting the network connection mode . . . . .	27		
3.3.3 Connecting to the network . . . . .	31		
3.4 Passcord connection . . . . .	32		
3.4.1 Getting the Passcode . . . . .	32		
3.4.2 Entering the Passcode . . . . .	34		
3.4.3 Configuring manually . . . . .	37		
3.5 Manual configuration . . . . .	41		
3.5.1 Profile connection . . . . .	41		
3.5.2 History connection . . . . .	42		
3.5.3 Configuring manually . . . . .	43		
3.6 Confirm the connection to your destination . . . . .	50		
3.6.1 Connection and transmission . . . . .	50		
3.6.2 Connection error . . . . .	52		
3.6.3 Setting the Live Mode . . . . .	53		
3.7 Start the "Live Viewer 3" . . . . .	54		
3.7.1 Main menu and Operating buttons . . . . .	54		
3.7.2 Displaying the status . . . . .	56		
3.7.3 Switching the display mode . . . . .	57		
3.7.4 Option menu . . . . .	58		
3.8 Profile data . . . . .	60		
3.8.1 Outline of Profile data . . . . .	60		
3.8.2 Making Profile data . . . . .	60		
3.8.3 Editing Profile data . . . . .	61		
3.8.4 Registering My Connection . . . . .	62		
<b>4. Management with Web browser software</b> . . . . .	<b>64</b>		
4.1 Configuring and controlling the projector via a web browser . . . . .	65		
4.1.1 Logon . . . . .	67		
4.1.2 Network Information . . . . .	68		
4.1.3 Network Settings . . . . .	69		
4.1.4 Port Settings . . . . .	71		
4.1.5 Mail Settings . . . . .	72		
4.1.6 Alert Settings . . . . .	73		
4.1.7 Schedule Settings . . . . .	75		
4.1.8 Date/Time Settings . . . . .	77		
4.1.9 Security Settings . . . . .	79		
4.1.10 Projector Control . . . . .	81		
4.1.11 Remote Control . . . . .	85		
4.1.12 Projector Status . . . . .	87		
4.1.13 Network Restart . . . . .	88		
4.1.14 Logoff . . . . .	88		
4.2 E-mail Alerts . . . . .	89		
4.3 Projector Management using SNMP . . . . .	91		
4.4 Event Scheduling . . . . .	92		
4.5 e-SHOT (Still Image Transfer) Display . . . . .	95		
4.6 Command Control via the Network . . . . .	96		
<b>5. PC-LESS Presentation</b> . . . . .	<b>101</b>		
5.1 Outline of the PC-LESS Presentation . . . . .	101		
5.2 Thumbnail mode . . . . .	103		
5.2.1 Starting the Thumbnail mode . . . . .	103		
5.2.2 Operating by buttons or keys . . . . .	105		
5.2.3 Operation on the Thumbnail menu . . . . .	106		
5.3 Full Screen Mode . . . . .	107		
5.4 Slide Show Mode . . . . .	109		
5.5 Directory Tree View . . . . .	111		
5.6 "PC-LESS Presentation" error message . . . . .	114		
5.7 Playlist . . . . .	115		
<b>6. Troubleshooting</b> . . . . .	<b>116</b>		
<b>7. Specifications</b> . . . . .	<b>118</b>		
<b>8. Warranty and after-sales service</b> . . . . .	<b>119</b>		



## Caution

**[Restriction in terms of inserts or pulls storage media and wireless network card]**

Do not pull out the wireless network card while the power is on. Do not touch the SD card while being accessed. The storage media can be pulled out only while not being accessed.

Perform the REMOVE MEDIA procedure or turn the projector off before pulling out the media. To perform the REMOVE MEDIA procedure, choose an suitable item among the REMOVE ALL, REMOVE SD CARD or REMOVE USB using the PC-LESS PRESENTATION menu under the MIU Menu. ([📄MIU Menu in the User's Manual \(detailed\) – Operating Guide](#))

**⚠ CAUTION**

■ The accompanying IEEE802.11b/g wireless network card uses the 2.4GHz radio frequency band. You do not need a radio license to use this card, but you should be aware of the following:

● **DO NOT USE NEAR THE FOLLOWING!**

- Microwave ovens
- Industrial, scientific or medical devices
- Designated low power radio stations
- Premises radio stations

Using the wireless network card near the above may result in radio interference, which in turn may result in a decrease in communication speed and even a complete loss of communication.

- Depending on the location where you attempt to use the wireless network card, there may be interference with the radio waves, which may result in a decrease in communication speed and even a complete loss of communication. In particular, please be aware that using the wireless network card in locations where there is reinforced steel, other metals and concrete may interfere with radio communication.
- Available Channels

The wireless network card uses the 2.4GHz radio frequency band, but depending on the country or region you are in, you might be limited to the channels you can use. Please refer to the following table for confirming where and with what channels you may use the accompanying IEEE802.11b/g wireless network card. Please consult with your dealer for countries not included in the table.

Country or Region	Available Channel
Japan	1 to 11
USA	1 to 11
Taiwan	1 to 11
Canada	1 to 11
UK, Spain, Germany, Italy, Austria, Switzerland, Belgium, Sweden, Netherlands, Portugal, Denmark, Finland, Greece, Norway, France, Ireland, Luxembourg, Iceland	1 to 11

- You may not bring the wireless network card into countries not listed above as there is a possibility that use of the wireless network card in those countries could lead to an infringement of established radio laws.

CE 0560 !

The manufacturer (Gemtek) hereby declare that this equipment (the wireless network card), model SD-Link11g is in compliance with the essential requirements and other relevant provisions of Directive 1999/5/EC.

## 1. Main functions

### 1.1 Live Mode (Project images from PC)

The MIU (Multi Information processing Unit) enables “Wireless presentation” by choosing Live Mode.

The Live Mode gives you an ability to display the same image that is shown on the PC through the network by using an application program “Live Viewer 3” that is required to install into your PC. (Fig.1.1.a)

The “Live Viewer 3” captures PC screen image and sends to the projector through wired LAN or wireless LAN connection. (📖 20)

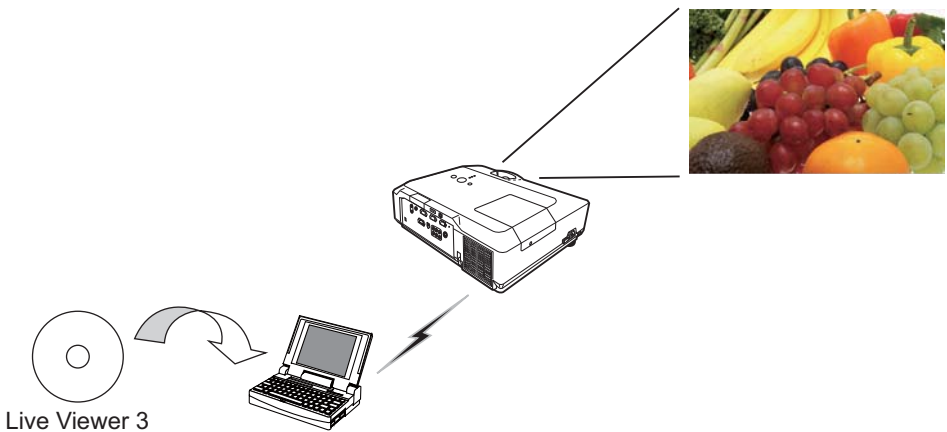

Fig. 1.1.a “Live Viewer 3” outlines (through wireless LAN connection)



Fig. 1.1.b “Live Viewer 3” Main menu

One projector can be connected with up to 4 PCs using “Live Viewer 3”. (📖 54)

### 1.2 Quick connection to your network

The “Live Viewer 3” brings you very quick and simple connection to your network. The “Live Viewer 3” prepares some options for you to match your requirement.

#### 1) Quick connection by the Passcode

The Passcode is a code that includes SSID and IP address and other information that are required for the network connection. The Passcode is given on screen by the projector, and then all you need to do is to input the code to the “Live Viewer 3” in your PC. (📖26)



Fig.1.2 PASSCODE on the projector screen

#### 2) Connection by the profile for the network

You can set the information to connect the projector to your network as a profile data in the “Live Viewer 3” in your PC. After that, you just select the profile data on the “Live Viewer 3” to connect the projector to your network.

#### 3) Connection by the history record for the network

Once you connect the projector to your network with the “Live Viewer 3”, the “Live Viewer 3” stores the history. You just select a history record to connect the projector to your network.

### 1.3 Configuring and controlling via a web browser

You can adjust or control the projector via a network from a web browser on a PC that is connected to the same network.

Logon the network from the web browser and it offers the menus to configure the network settings, monitor the projector and so on. The Web Remote Control, one of the menus of web browser, allows you to control the projector like bundled remote control including operating the “Live Mode” and “PC-LESS Presentation”.

(📖 64)

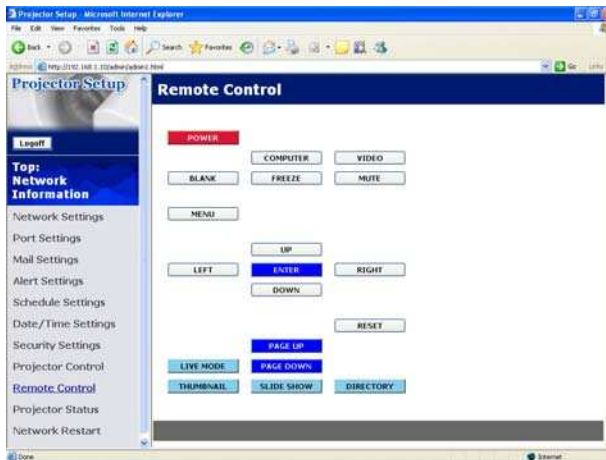

Fig. 1.3. Web Remote Control

### 1.4 PC-LESS Presentation

#### (Display the images stored in SD memory card/USB memory.)

The MIU enables “PC-LESS Presentation” by choosing PC-LESS function. (Fig. 1.4)

The PC-LESS function enables to display images that are stored in a storage media like SD memory card or USB memory. The “PC-LESS Presentation” has 4 types of display modes.

- 1) Thumbnail Mode: Display thumbnails of stored images in the storage media.  
(After this, “the storage media” is the general term for both of SD memory card and USB memory.)
- 2) Full Screen Mode: Display selected image or movie on the full screen mode.
- 3) Slide Show Mode: Display images in the Slide show mode with certain interval.
- 4) Directory Tree View: Display files and folders that are stored in the storage media as directory tree view.

#### [Supported storage media]

- SD memory card
- USB memory (USB memory type, USB hard disk and USB card reader type)

**NOTE** • USB memory reader (adapter) is not supported (if the adapter acknowledges as multiple devices connected).  
• The supported formats are FAT 12, FAT 16(FAT) and FAT 32.  
NTFS is not supported.  
• USB hub is not supported.

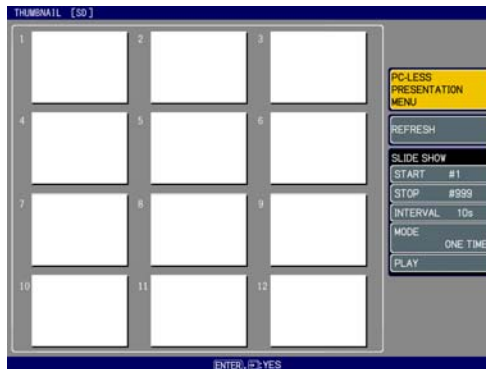

Fig. 1.4 “PC-LESS Presentation” outlines

“PC-LESS Presentation” can be controlled via keypad on the projector or remote control (101).

#### 1.4 PC-LESS Presentation

*(Display the images stored in SD memory card/USB memory.) (continued)*

**NOTE** • There are several naming limitations for the folders and files.

(1) Alphanumeric and Japanese characters are supported if the language setting is Japanese.

(2) Alphanumeric and Latin-1 characters are supported if the language setting is NOT Japanese.

- The files may not be able to access depending on the type of USB hard disk, USB memory and USB card reader.

- It is recommended to use external power supply cable if the USB hard disk drive has the power cable.

## 2. Equipment connection and network setting

### 2.1 Required equipment preparation

The following equipments are required to connect the projector to your PC through the network.

- **Common** The projector: 1 unit, PC : 1 set \*1  
It is recommended to install the “Live Viewer 3” into the PC.

- **Depending on how you want to connect**

- 1) For the wired connection  
LAN cable (CAT-5 or greater): 1 piece
- 2) For the wireless connection \*2
  - Projector side  
The Wireless Network Card : 1 unit
  - PC side  
IEEE802.11b/g wireless LAN equipment: 1 unit \*3

\*1: For the PC, please refer to the item 3.2.1 Minimum PC hardware and software requirement. (📖23)

\*2: An access point is required when the wireless LAN connection is used as Infrastructure mode.

\*3: Depending on the type of wireless network device and PC you are using, the projector may not be able to communicate properly with your PC, even if the PC you are using is equipped with built-in wireless LAN function.

To eliminate communication problems, please use a Wi-Fi certified wireless network device.

### 2.2 Quick connection

The “Live Viewer 3” supports very quick and simple connection to the network. It is strongly recommended to install the “Live Viewer 3” into your PC to enjoy the feature. Proceed to the installation of the “Live Viewer 3” (📖23) and the connection. (📖26)

In case you don't want to use the “Live Viewer 3” or you cannot use it by some reason, proceed to the manual setting, the item 2.3 for the wired LAN (📖11) and the item 2.4 for the wireless LAN. (📖16)



## 2.3 Manual network connection setting - Wired LAN -

If you don't use the "Live Viewer 3", you need to set up your network connection manually.

This section explains how to set it up manually.

### 2.3.1 Equipments connection

Connect the projector and PC with a LAN cable.

\* Before connecting with an existing network, contact the network administrator.

Next, please check the PC setting as explained below.

### 2.3.2 Network settings

This is the explanation of network connection settings for Windows XP and Internet Explorer.

- 1) Log on to Windows XP as administrator authority. (\*)
- 2) Open "Control Panel" from "Start" menu.
- 3) Open "Network and Internet Connections" in "Control Panel". (Fig. 2.3.2.a)

\* Administrator authority is the account, which can access to all functions.

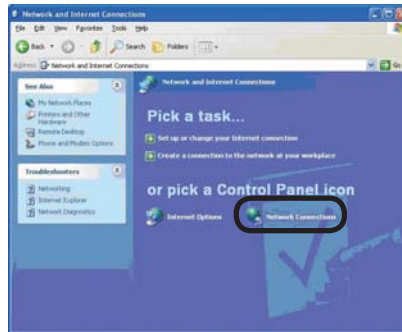

Fig. 2.3.2.a "Network and Internet Connections" window

- 4) Open "Network Connections". (Fig.2.3.2.b)

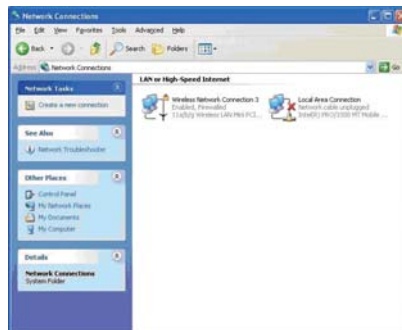

Fig. 2.3.2.b "Network Connections" window

### 2.3 Manual network connection setting - Wired LAN - (continued)

- 5) Open “Local Area Connection Properties” window you use for network device.  
(Fig. 2.3.2.c)



Fig. 2.3.2.c “Local Area Connection Properties” window

- 6) Set used protocol as “TCP/IP” and open “Internet Protocol (TCP/IP) Properties” window.

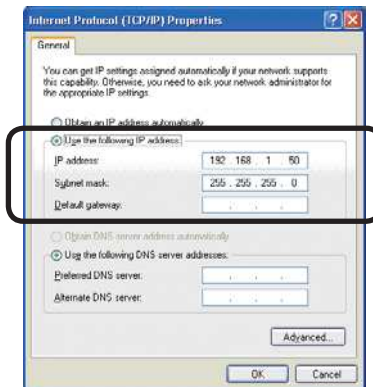

Fig. 2.3.2.d “Internet Protocol (TCP/IP) Properties” window

- 7) Set IP address, subnet mask and default gateway for PC.

### 2.3 Manual network connection setting - Wired LAN - (continued)

#### [About IP address]

##### ■ Setting manually

The Network address portion included in the IP address set into your PC should be common with projector's one. And the entire IP address in the PC should not be overlapped with other equipments in the same network, including the projector.

For example

The projector's initial settings are as follows.

IP address: 192.168.1.10

Subnet mask: 255.255.255.0

(Network address: 192.168.1 in this case)

Therefore, specify PC's IP address as follows.

IP address: 192.168.1.xxx (xxx shows decimal number.)

Subnet mask: 255.255.255.0

(Network address: 192.168.1 in this case)

Select from 1 to 254 for "xxx" not duplicating with any other equipments.

In this case, projector has "192.168.1.10" IP address, specify from 1 to 254 except 10 for PC.

**NOTE** • "0.0.0.0" cannot be set to the IP address.

- The projector's IP address can be changed by using the configuration utility via a web browser. (P.65)
- If the projector and PC exist in the same network (i.e. network address is common), default gateway can be blank.
- When the projector and PC exist in different networks, default gateway setting is necessary. Contact the network administrator in detail.

##### ■ Setting automatically

When DHCP server exists in network, it is possible to assign IP address to the projector and PC automatically.

\* DHCP is abbreviation for "Dynamic Host Configuration Protocol" and has the function to provide necessary setting for network like IP address from server to client. A server that has DHCP function is called DHCP server.

### 2.3 Manual network connection setting - Wired LAN - (continued)

#### 2.3.3 “Internet Option” setting

- 1) Click “Internet Options” in “Network and Internet Connections” window (Fig. 2.3.3.a) to open “Internet Properties” window. (Fig. 2.3.3.b)

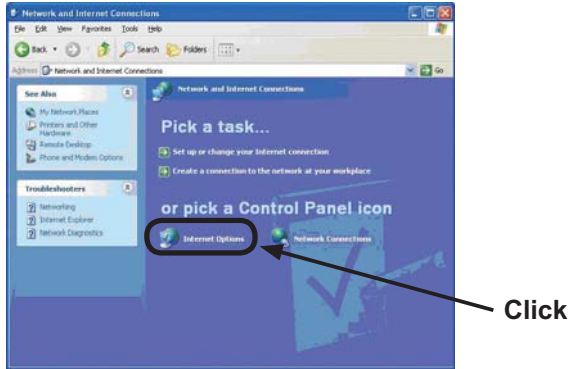

Fig. 2.3.3.a “Network and Internet Connections” window

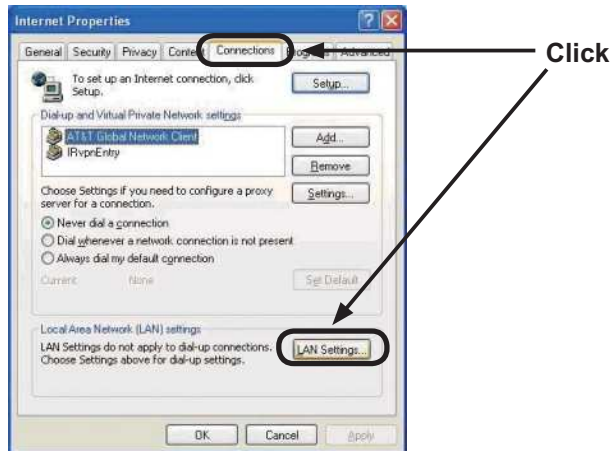

Fig. 2.3.3.b “Internet Properties” window

- 2) Click “Connections” tab and then click [LAN Settings] button to open “Local Area Network (LAN) settings”. (Fig. 2.3.3.c)

### 2.3 Manual network connection setting - Wired LAN - (continued)

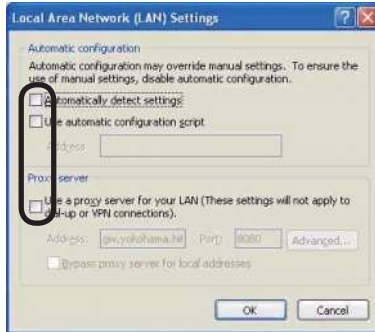

Fig. 2.3.3.c “Local Area Network (LAN) Settings” window

3) Uncheck all boxes in “Local Area Network (LAN) Settings” window. (Fig. 2.3.3.c)

### 2.3.4 Check connection

Check PC and projector are connected properly here. If it is not connected, check cable connections and settings are properly or not.

1) Start browser in PC and specify following URL, then click “Go” button.

URL: [http://\(Projector IP address\)/](http://(Projector IP address)/)

For example, if projector IP address is 192.168.1.10, specify

URL: <http://192.168.1.10/>

2) If Fig. 2.3.4 appears, it succeeds.

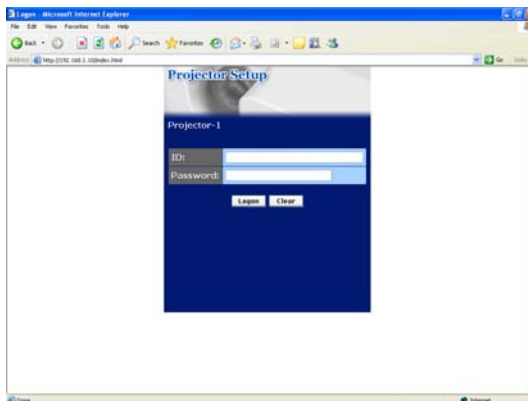

Fig. 2.3.4 “Logon Menu”

### 2.4 Manual network connection setting –Wireless LAN

The projector and PC can communicate in both of Ad-Hoc and Infrastructure modes, using the designated wireless network card on the projector. This section is intended to explain how to set up wireless LAN connection manually.

#### 2.4.1 Preparation for wireless LAN connection

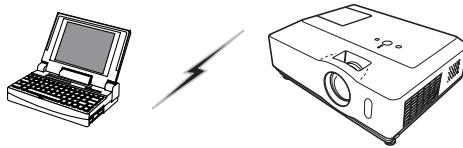

Fig. 2.4.1.a Without an access point communication (Ad-Hoc)

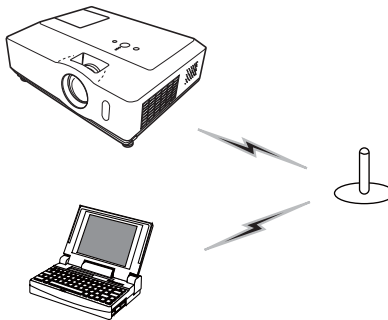



Fig. 2.4.1.b With an access point communication (Infrastructure)

- \* Ad-Hoc is one of the wireless LAN communication methods without having access point to communicate.
  - \* Infrastructure is one of the wireless LAN communication methods with having access point to communicate. If certain quantities of equipments are used, this mode is efficient.
- If communicating with existing network, contact your network administrator.

First, insert the wireless network card into SD card slot ( **Using an SD card of the User's Manual (concise)** ).

Then, make PC ready for wireless communication.

In case IEEE802.11b/g wireless LAN device is built-in the PC, make it valid and make other network connections invalid. If wireless LAN device is not built-in the PC, connect IEEE802.11b/g wireless LAN device and install device driver. (Refer to the user guide for PC and wireless LAN device for detail.)

## 2.4 Manual network connection setting –Wireless LAN (continued)

### 2.4.2 Wireless LAN connection set up

Using wireless LAN utility for Windows XP standard.

Wireless LAN initial settings for the projector is as follows.

Connection Control	: Ad-Hoc
SSID	: wireless
Channel	: 1ch
Encryption rating	: None
Communication speed	: AUTO
IP address	: 192.168.1.10

\* You can change these settings as you want via a web browser on your PC or the menu on the projector. Refer to the item **4.1.3 Network Settings** (69) or **MIU Menu in the User's Manual (detailed) – Operating Guide**.

1) Open "Network Connections". (Fig. 2.4.2.a)

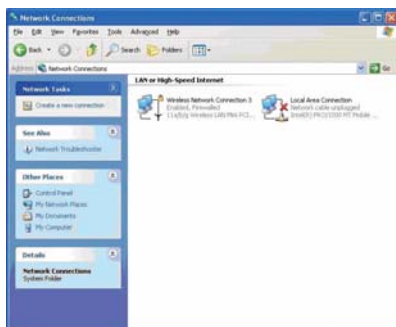

Fig. 2.4.2.a "Network Connections"

2) Open "Wireless Network Connection Properties". (Fig. 2.4.2.b)

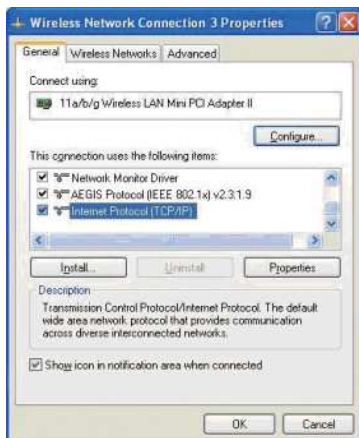

Fig. 2.4.2.b "Wireless Network Connection Properties" window (1)

### 2.4 Manual network connection setting –Wireless LAN (continued)

- 3) Set used protocol as “TCP/IP” and open TCP/IP property. Set IP address and other settings as same as wired LAN connection set up. (📖12)
- 4) Open “Wireless Networks” tab. (Fig. 2.4.2.c)



Fig. 2.4.2.c “Wireless Network Connection Properties” window (2)

- 5) Add check mark for “Use Windows to configure my wireless network settings” in “Wireless Network Connection Properties” window.
- 6) Click **[Add]** button in “Preferred networks” section in “Wireless Network Connection Properties” window (Fig. 2.4.2.c) to open “Wireless network properties” window. (Fig. 2.4.2.d)

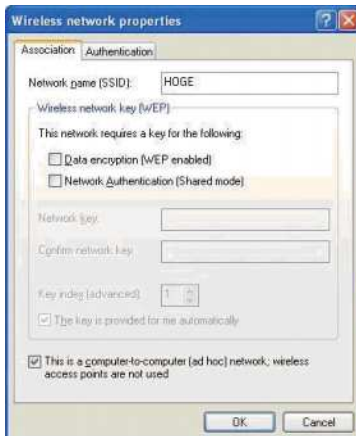

Fig. 2.4.2.d “Wireless network properties” window



### 2.4 Manual network connection setting –Wireless LAN (continued)

7) Set each item as follows.

Network name (SSID): wireless

Data encryption: not enabled (Default setting is not enabled.)

**NOTE** • If the default setting in the projector is used, set the data as above into your PC. If an access point is used or any encryption mode is used, it is required to set the data that is matched to your system.

Refer to the manuals for your PC or wireless LAN adapter or access point.

• If you want to use the existing network via an access point, contact your network administrator before the connection.

## 3. Using the Live Mode

The section is intended to explain the process to use the projector in the Live Mode.

The outline of the process is as follows.

### 1) Install the “Live Viewer 3” (📖23)

### 2) Quick Connection to the network (📖26)

The Quick Connection feature prepares some options to connect your network. You can select one that meets your requirement.

- Passcode connection
- Profile data connection
- History record connection
- My Connection
- Manual connection

### 3) Confirm the connection to your destination (📖50)

In some case, there are several projectors connected to the same network. Before you send your image, confirm that the right projector is selected.

### 4) Start the Live Mode (📖54)

The “Live Viewer 3” main menu will be on screen.

Now, you can send your images to the projector through the network.



Fig. 3 “Live Viewer 3” Main menu

### 3.1 Outline of the Live Mode

The Live Mode can display PC's image on screen in real time through either wired or wireless LAN. So, no signal cable connection is required.

#### 3.1.1 Display mode

In the Live Mode, there are two display modes, Single PC mode and Multi PC mode.

##### 1) Single PC mode

The projector displays images sent by one PC.

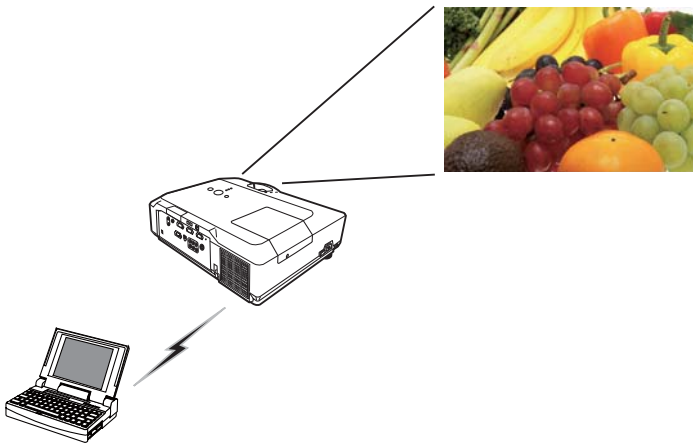

##### 2) Multi PC mode

The projector screen is divided to 4 zones. The projector displays images in one zone sent by a PC, so that the projector can display images sent by up to 4 PCs at the same time.

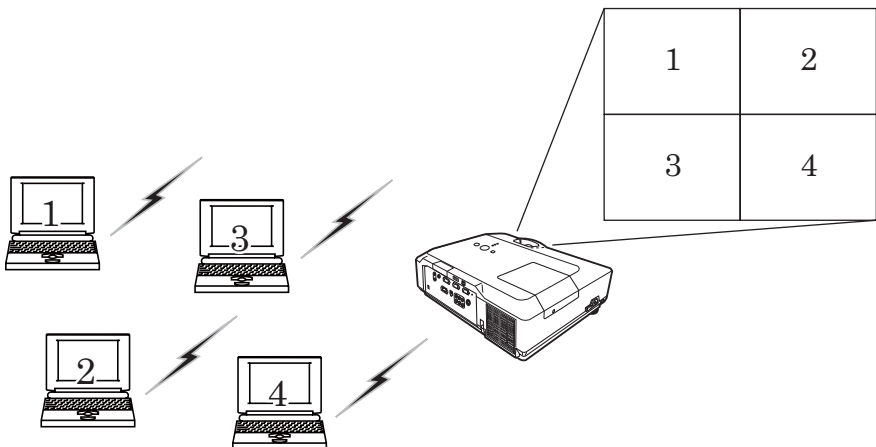

### 3.1 Outline of the Live Mode (continued)

#### 3.1.2 Presenter mode

In the Single PC mode, the projector can be occupied by one PC and can block an access from any other PC, if the Presenter mode is set to on in the “Live Viewer 3”.

While making your presentation, you don't need to worry that the image on screen is unexpectedly switched to an image sent by another PC.

The Presenter mode can be set on the Option menu in the “Live Viewer 3” main menu. (📖58)

#### 3.1.3 Display User Name

The user name can be input in the “Live Viewer 3”, which is displayed on screen by operating the menu on the projector. So, it can be found out whose image is currently displayed on screen. (📖58)

## 3.2 Install “Live Viewer 3”

In order to use the Live Mode and Quick connection, you need to install the enclosed software, the “Live Viewer 3”, into all PCs that you want to connect to the projector through the network.

### 3.2.1 Minimum PC hardware and software requirement

- OS: Windows 2000 Professional Service Pack4, Windows XP Home Edition/Professional
- Graphic Interface: Video RAM 4MB or higher (8MB recommended)
- CPU: Pentium III (600MHz or higher recommended)
- Display: VGA 640x480 or higher (XGA 1024x768 recommended)  
65,536 simultaneous colors or higher

**NOTE** • For Windows VISTA, use the latest “Live Viewer 3”. Please get the latest version at Hitachi WEB site (<http://hitachi.us/digitalmedia> or <http://www.hitachidigitalmedia.com>).

Since some functions maybe limited, please see the instruction manual that is supplied with the latest “Live Viewer 3”.

- Set your PC’s resolution to XGA or less. Refer to the user manual for your PC or Windows.
- In some cases, your PC’s screen will not be displayed correctly by the projector. If the resolution is larger than 1024x768, the projector can display only the 1024x768 portion of the image.
- Images might not been transmitted, caused by OS version or the driver software for Network Adapter on your PCs. It is highly recommended that OS and the driver should be updated to the latest.

- Memory: 64MB or higher (128MB or higher if using Windows XP)
- Available Hard Disk Space: 10MB or higher
- Web browser: Internet Explorer® (5.5 or higher)
- CD-ROM drive
- Wireless: IEEE802.11b/g

**NOTE** • Depending on the type of wireless network device and PC you are using, the projector may not be able to communicate properly with your PC, even if the PC you are using is equipped with built-in wireless LAN functionality. If the communication problems occur, please use a Wi-Fi certified wireless network device.

## 3.2 Install “Live Viewer 3” (continued)

### 3.2.2 Software Installation Procedure

- 1) Turn on the PC.
- 2) Shut down all applications.
- 3) Insert the accompanying CD-ROM into the PC's CD-ROM drive.
- 4) After a moment, the Welcome dialog will appear as shown on the right. Press **[Next]**.

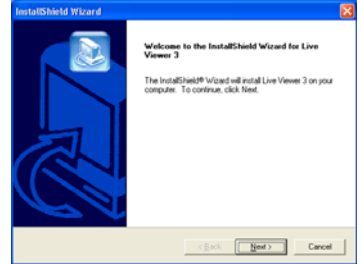

**NOTE** • If the Welcome dialog doesn't appear, proceed as follows:

- (1) Click on the [Start] button on the toolbar and select the “Run”.
- (2) Enter **E:\software\setup.exe** and then press **[OK]**.

↑  
If your CD-ROM drive is not drive E on your PC, you will need to replace E with the correct drive letter assigned to your CD-ROM drive.

If the software has been already installed, Uninstallation will be done. Click **[Cancel]** button, then uninstallation will be canceled. If you uninstalled the software by miss-operation, please re-install the software from first procedure.

- 5) The License Agreement dialog appears. If you accept it, press **[Yes]**.
- 6) The Choose Destination Location dialog appears. Press **[Next]**.

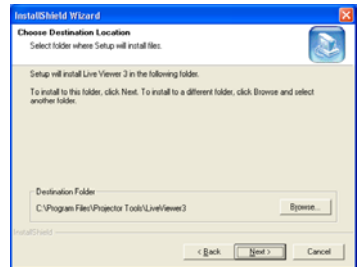

**NOTE** • The C:\Program Files\Projector Tools\LiveViewer3 folder will be created and the program will be installed into that folder. If you wish to install to a different folder, click **[Browse]** and select another folder.

- 7) Confirm the program folder name. If “Projector Tools” is okay, press **[Next]** to continue. If not, enter the desired folder name and then press **[Next]**.

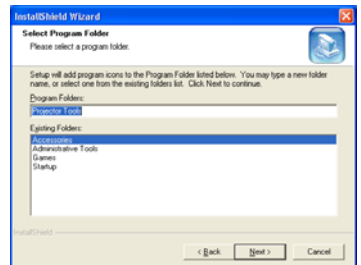

### 3.2 Install “Live Viewer 3” (continued)

8) The Hardware Installation dialog appears. Press Continue Anyway.

9) After a moment, installation will complete and the Setup Complete dialog will appear as shown on the right. Click **[Finish]**. This completes the software installation. Then your PC automatically restarts.



(1) To confirm that the software has been properly installed, press **[Start]** button on the toolbar, select All Programs and then select the Projector Tools folder.

(2) The “Live Viewer 3” will appear in that folder if the installation was successful.

#### 3.2.3 Version of the “Live Viewer ” software

To use the Live Mode, it is required to install the software, the “Live Viewer”, into the PC that is going to be connected to the projector through the network. The right software version is depended on the models that you have. If the version is not matched with the projector, the software will not work properly.

Live Viewer Version	Models			
	CP-X267	CP-X268A CP-X608	CPX2	CP-X308 CP-X417 CP-X807
2.01	○	×	×	×
2.1x	×	○	○	×
2.20	×	○	○	×
3.xx	×	○	○	○

• “x” in the version means 0 or greater.

Please check and get the latest version at Hitachi Web site.

<http://hitachi.us/digitalmedia> or <http://www.hitachidigitalmedia.com>

### 3.3 Quick connection to the network

The Live Mode prepares some options for the network connection. You can choose one that meets to your system.

The explanation here is based on the case that Windows XP is installed in your PC.

#### 3.3.1 Starting the “Live Viewer 3”

Start the “Live Viewer 3” in your PC, taking one of the followings.

- 1) Double click the “Live Viewer 3” icon on the Desktop in your PC
- 2) Select “Start” → “All Programs” → “Projector Tools” → “Live Viewer 3” on Windows XP menu.

Then, proceed to the item **3.3.2 Selecting the connection mode.** (📖27)

#### [trouble shooting]

- In order to display the computer image correctly, you will need to change the screen resolution.

If the resolution on your PC is set higher than XGA(1024x768), the screen is displayed.

To change the resolution, click **[Yes]**.  
Not to change the resolution, click **[No]**.

If you click **[Yes]**, the resolution on your PC is switched to XGA(1024x768).

If you click **[No]**, the resolution is not changed.

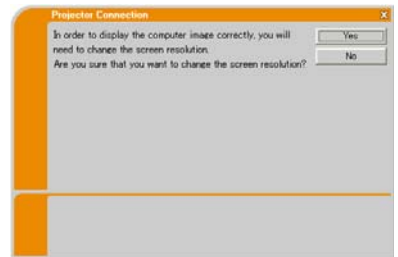

- NOTE** • When the resolution is changed, the arrangement of icons on PC Desktop screen may be changed.
- Even if the resolution is changed, it will be back to the original when the “Live Viewer 3” is closed.
  - If the resolution is not changed, the projector will display XGA(1024x768) portion from top left corner of your PC screen.
  - Refer to the user manual for your PC or Windows to change the resolution.



### 3.3 Quick connection to the network (continued)

#### 3.3.2 Selecting the network connection mode

After starting the “Live Viewer 3”, the “Select the Network Connection” screen comes up. Select the network connection that you would like to use. There are 3 options in the menu.

- Wireless LAN
- Wired LAN
- My Connection

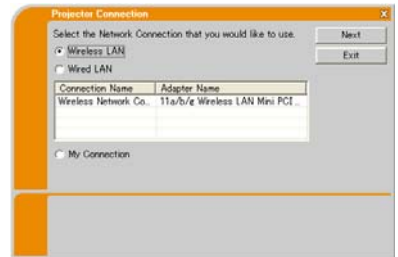

If you select either the wireless LAN or wired LAN, proceed to the **Selecting either the wireless LAN or wired LAN** below.

If you select the My Connection, jump to the **Selecting the My Connection.** (📖29)

#### Selecting either the wireless LAN or wired LAN

If you select either the wireless LAN or wired LAN, a list of the network adapters in your PC is shown in the menu.

Select what you like to use in the list, and click **[NEXT]**.

Then, proceed to the item **3.3.3 Connecting to the network.** (📖31)

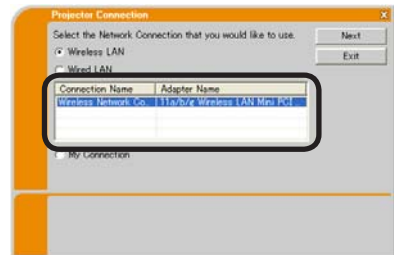

**NOTE** • If you select the wireless LAN, the wireless LAN adapters in your PC are shown in the list.

• If the wired LAN is selected, the wired LAN adapters in your PC are shown.

#### [trouble shooting]

##### ■ Are you sure that you want to turn on the network adapter?

The screen is displayed in the case that the selected network adapter is invalid.

- To turn it on, click **[Yes]**, and then proceed to the item 3.3.3 (📖31)
- Not to turn it on, click **[No]**, and then the screen is back to the previous one to select another network adapter. If no more adapter in your PC, the “Live Viewer 3” will be closed.



#### 3.3 Quick connection to the network (continued)

- A network connection was not established.  
The screen is displayed in the case that the projector is not connected with a LAN cable to your PC when the wired LAN is selected.

Be sure that the projector is connected with a LAN cable to your PC.

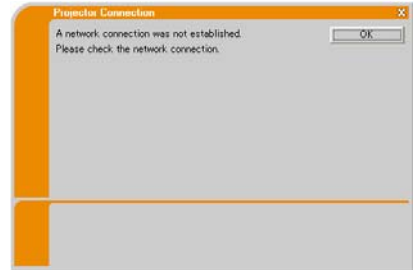

Click **[OK]**, then the screen is back to the previous one to select the network connection mode.

- Windows firewall is enabled(On).  
The screen is displayed in the case that the firewall setting in Windows XP is activated, and the “Live Viewer 3” is blocked by the firewall.

- To turn it disabled(Off), click **[Yes]**.
- Not to turn it disabled(Off), click **[No]**, but the projector may not be able to communicate with your PC through the network.

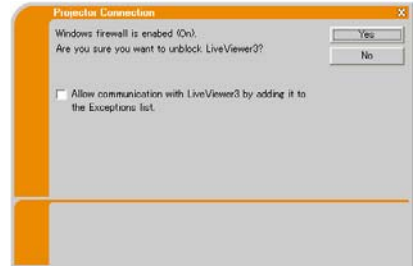

- If you put a check mark in the **[Allow communication with LiveView3 by adding it to the Exceptions list]** box, the “Live Viewer 3” will never be blocked by Windows firewall.

Proceed to the item 3.3.3 **Connecting to the network.** (📖31)

**NOTE** • If you click **[Yes]**, the network access by the “Live Viewer 3” is temporarily permitted by Windows firewall, until the “Live Viewer 3” is closed.  
• If any application software having the firewall function is installed into you PC, make the firewall function invalid with following the user’s manual.

### 3.3 Quick connection to the network (continued)

#### Selecting the My Connection

Select **[My Connection]** and click **[Connect]**.

If you select the My Connection, the PC is connected to the projector through the network by using the profile data that is pre-assigned to My Connection. (📖62)

When you select the My Connection, the PC immediately starts the connection to the projector.



Proceed to the item 3.6 **Confirm the connection to your destination.** (📖50)

**NOTE** • If the DHCP is set on in the projector, the network connection between the projector and PC may not be established since IP address may be varied. If you like to use the My Connection, set the DHCP off in the projector.

- If no profile data is assigned to the My Connection, it can't be used.

#### [trouble shooting]

- A network connection could not be established.

Windows prevented network configuration changes.

You may log in the Windows under User authority.

Click **[OK]** to return to the screen to select the network connection mode. (📖27)



Consult to the network administrator and log in again under the Administrator authority. After that, please resume at the item **3.3.1 Starting the “Live Viewer 3”**. (📖26)

#### 3.3 Quick connection to the network (continued)

##### ■ Are you sure you want to connect the selected projector?

The message is appeared when the wireless adapter you selected is already used for another network connection.

- To connect, click **[Yes]**. Proceed to the **3.6 Confirm the connection to your destination.** (📖50)
- Not to connect, click **[No]** to return to the screen to select the network connection mode. (📖27)



### 3.3 Quick connection to the network (continued)

#### 3.3.3 Connecting to the network

There are some options to connect to the network.

- Enter PassCode
- Configure Manually
- Select From List

Select one of them to meet your requirement.

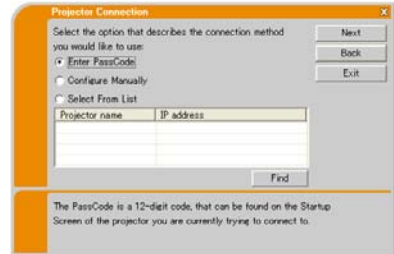

#### Enter PassCode

If you want to use the Passcode for network connection, select **[Enter PassCode]** and click **[NEXT]**.

The Passcode is given by the projector on screen. And you simply input the Passcode to the “Live Viewer 3” to connect the network.

Proceed to the 3.4 **Passcode connection**. (📖32)

#### Configure Manually

Select **[Configure Manually]** and click **[NEXT]**.

Then, there are 3 options on the manual connection method.

- **Profile** Proceed to the 3.5.1 **Profile connection** (📖41)  
You just select one of the stored profile data to connect the network.
- **History** Proceed to the item 3.5.2 **History connection** (📖42)  
Once connecting to the network, the “Live Viewer 3” stores the history.  
If you need the same connection again, select **[History]**.  
Then, all you need to do is to select one of the history data from the list.
- **Configure Network Settings Manually** Proceed to the item 3.5.3 **Configuring manually** (📖43)  
If you need to make the setting manually, select **[Configure Network Settings Manually]**.

#### Select From List

Before selecting this item, your PC and the projectors need to be connected to the same network.

If the connection is already established, select **[Select From List]**.

From the list of the projectors connected to the network, select which projector you would like to send your images. Proceed to the 3.6 **Confirm the connection to your destination**. (📖50)

## 3.4 Passcode connection

The unique Passcode system brings you very quick and simple connection to the network.

The Passcode is a code that expresses the network setting in the projector. If you input the code in the “Live Viewer 3” in your PC, the network setting in the projector and PC can be matched and the connection will be established immediately.

The section is intended to explain how to use the Passcode.

### 3.4.1 Getting the Passcode

The Passcode is 12-digit code consisting of alphanumeric characters (“1-9” and “A-Z”). Example: PASSCODE 1234-5678-9ABC

The Passcode is given on the projector screen.

**NOTE** • The Passcode system does not work under the condition below. If your system meets one of them, set the connection manually.

1) Any encryption code is used.

The Passcode system does not work with an encryption code.

2) Unique SSID is used.

The Passcode system accepts the factory default SSID only.

Factory default SSID 1 : wireless

Factory default SSID 2 : WLANProjector1

Factory default SSID 3 : WLANProjector2

Factory default SSID 4 : WLANProjector3

3) Subnet mask is not Class A or B or C.

The Passcode system accepts Class A, B and C only.

Class A:(255.0.0.0), ClassB:(255.255.0.0), Class C:(255.255.255.0)

There are two methods to get the Passcode from the projector

#### Method 1

- 1) Turn on the projector, and make sure that the projector image is on screen.
- 2) Press the COMPUTER button on the remote control or INPUT button on the projector to select the MIU as input port.  
If there is no signal on the MIU port you can find the Passcode on screen, otherwise proceed to 3) below.
- 3) Press the MENU button on the remote control or the ▲/▼/◀/▶ buttons on the projector to show the menu on screen.
- 4) Use the ▲/▼ cursor buttons to select the Advanced Menu, and use the ► cursor button to enter the item.
- 5) Use the ▲/▼ cursor buttons to select the MIU, and use the ► cursor button to enter the item.
- 6) Use the ▲/▼ cursor buttons to select the LIVE MODE, and push the ► cursor button.
- 7) The Passcode is appeared on the screen.

### 3.4 Passcode connection (continued)

#### Method 2

- 1) Turn on the projector, and make sure that the projector image is on screen.
- 2) Press the MENU button on the remote control or the ▲/▼/◀/▶ buttons on the projector to show the menu on screen.
- 3) Use the ▲/▼ cursor buttons to select the Advanced Menu, and use the ► cursor button to enter the item.
- 4) Use the ▲/▼ cursor buttons to select the MIU, and use the ► cursor button to enter the item.
- 5) Use the ▲/▼ cursor buttons to select the INFORMATION, and use the ► cursor button to display the INFORMATION.
- 6) The Passcode is appeared at the top right corner in the INFORMATION window.

**NOTE** • Take the Method 2 , when you use the projector in the LIVE MODE or PC-LESS Presentation mode, or when the MIU is not selected as the input signal.

- If no communication between the projector and PC in 5 minutes, the Passcode will be changed.

#### 3.4 Passcode connection (continued)

##### 3.4.2 Entering the Passcode

If you select **[Enter PassCode]** at the item 3.3.3, the “Please enter the PassCode” screen is displayed. Please enter the Passcode divided 4-digit each in 3 boxes (total 12-digit).

Example PASSCODE: 1234 – 5678 - 9ABC

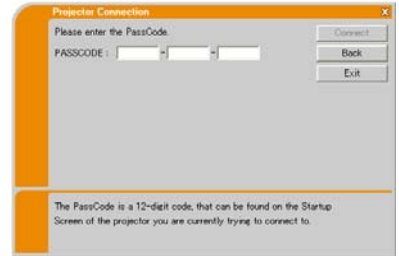

After entering the Passcode, click **[Connect]** to start the connection to the projector.

Proceed to the item 3.6 **Confirm the connection to your destination.** (📖50)

If you click **[Back]**, the screen is back to the item 3.3.3 Connecting to the network. (📖31)

**NOTE** • When entering the Passcode, capital and small letters are not distinguished.  
• If you are using any encryption code or your unique SSID or Subnet mask excluding ClassA and B and C, it is required to set the connection manually. If the manual setting screen is displayed, please follow the item 3.4.3.

#### [trouble shooting]

##### ■ Incorrect PassCode.

The incorrect Passcode was input.

Click **[Back]** to return to the “Please enter the PassCode” screen.

Check the PassCode on the projector screen (📖32) and enter the code again.

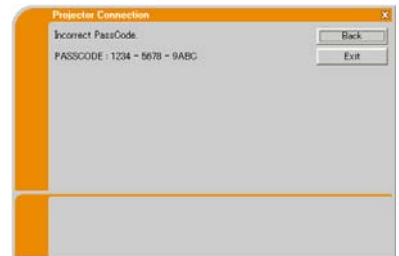





### 3.4 Passcode connection (continued)

- A network connection could not be established. Windows prevented network configuration changes.

You may log in the Windows under User authority.

Click **[OK]**, then the “Live Viewer 3” main menu is displayed even though the network is not established. Click  on the main and go back to the item **3.3.3 Connecting to the network**. (31)



Consult to the network administrator. Log in the Windows under Administrator authority. After that, please resume at the item **3.3.1 Starting the “Live Viewer 3”**. (26)

- Automatic connection failed. The reason is that the IP address set in the projector is the global address.

Following the instruction by the network administrator, set the IP address and Subnet mask in the “Live Viewer 3”.

After input these address, click **[Connect]**.



If you want to erase the information you input, click **[Reset]**.



**NOTE** • If the IP address you input to the PC is the same as the one set in the projector, a warning message will come up. Please choose an IP address that is currently not in use.

#### 3.4 Passcode connection (continued)

- A Network Configuration Conflict exists.

The message comes up when the network connection mode you set in the PC does not match with the mode of the projector.

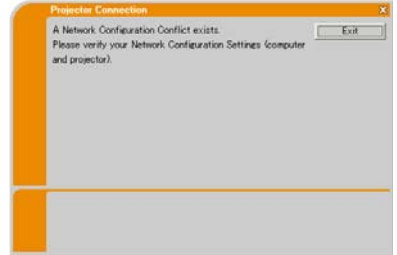

Please verify your network configuration setting on the projector and PC.

Click **[Exit]**, then the “Live Viewer 3” main menu is displayed even though the network is not established. Click  on the main menu to go back to the item **3.3.3 Connecting to the network**. ( 31)



- Are you sure you want to connect the selected projector?

The message is appeared when the wireless adapter you selected is already used for another network connection.

- To connect, click **[Yes]**. Proceed to the **3.6 Confirm the connection to your destination**. ( 50)
- Not to connect, click **[No]** then the “Live Viewer 3” main menu is displayed even though the network is not established. Click  on the main menu to go back to the item **3.3.3 Connecting to the network**. ( 31)

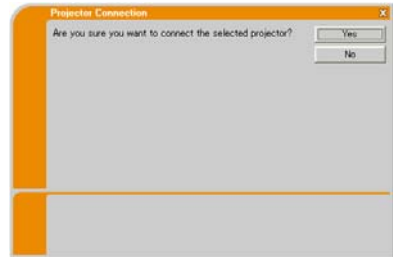

### 3.4 Passcode connection (continued)

#### 3.4.3 Configuring manually

After you input the Passcode (📖34), you are required to input the network setting manually if you use any encryption code or your unique SSID or Subnet mask except Class A/B/C. (📖32)

If you use the wired LAN, go to (📖40).

#### Wireless LAN

The required information depends on how you connect the projector and PC.

- Direct connection between the projector and PC (AdHoc mode)
- The projector connected to an access point by a LAN cable
- The projector connected to an access point by the wireless LAN

#### Direct connection between the projector and PC (AdHoc mode)

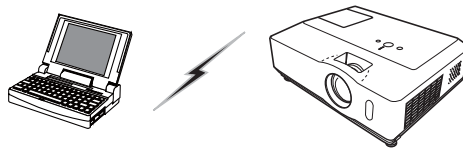

1) Enter the following information that is set in the projector. \*1

SSID \*2: wireless (example)  
 Encryption: WEP64bit (example)  
 Encryption key \*3: \*\*\*\*\* (example)  
 Subnet mask \*4: 255.255.255.128  
 (example)

2) Click [**Connect**].

3) The wireless connection will be established.  
 Proceed to the item 3.6 **Confirm the connection to your destination.** (📖50)

\*1 To find the network setting on the projector, refer to the NOTE. (📖40)

\*2 If you don't use the factory default SSID, you need to set your SSID by either entering manually or selecting from the list of detected SSID.

\*3 If you use an encryption, you need to set it. Contact the network administrator to find the encryption key that is set in the projector.

The encryption key is always shown as "\*\*\*\*\*".

\*4 If you use Subnet mask except Class A/B/C, please set it.

#### 3.4 Passcode connection (continued)

The projector connected to an access point by a LAN cable

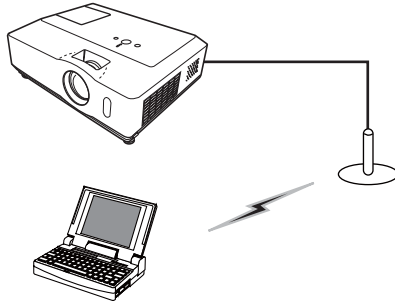

1) The setting on the access point. **\*1**

Enter the following information.

SSID : WirelessAccessPoint (example)

Encryption: WEP64bit (example)

Encryption key **\*2**: \*\*\*\*\* (example)

2) The setting on the projector. **\*3**

Enter the following information.

Subnet mask **\*4**: 255.255.255.128  
(example)

3) Click **[Connect]**.

4) The wireless connection will be established.

Proceed to the item 3.6 **Confirm the connection to your destination.** (📖50)

**\*1** Contact the network administrator to find out the setting on the access point.

**\*2** If you use an encryption, you need to set it. Contact the network administrator to check the encryption key that is set in the projector.

The encryption key is always shown as “\*\*\*\*\*”.

**\*3** To find the network setting on the projector, refer to the NOTE. (📖40)

**\*4** If you use Subnet mask except Class A/B/C, please set it.



### 3.4 Passcode connection (continued)

The projector connected to an access point by the wireless LAN

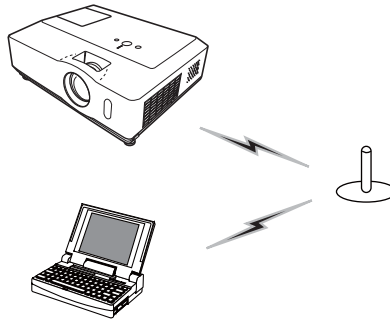

1) Enter the following information that is set in the projector. \*1

- SSID \*2: wireless (example)
- Encryption: WEP64bit (example)
- Encryption key \*3: \*\*\*\*\* (example)
- Subnet mask \*4: 255.255.255.128 (example)

2) Click [**Connect**].

3) The wireless connection will be established.

Proceed to the item 3.6 **Confirm the connection to your destination.** (📖50)

\*1 To find the network setting on the projector, refer to the NOTE. (📖40)

\*2 If you don't use the factory default SSID, you need to set your SSID by either entering manually or selecting from the list of detected SSID.

\*3 If you use an encryption, you need to set it. Contact the network administrator to find the encryption key that is set in the projector.

The encryption key is always shown as "\*\*\*\*\*".

\*4 If you use Subnet mask except Class A/B/C, please set it.

#### 3.4 Passcode connection (continued)

##### Wired LAN

- 1) Enter the following information for the projector.  
Subnet mask \*1: 255.255.255.128  
(example)
- 2) Click [**Connect**].
- 3) The network connection will be established.  
Proceed to the item 3.6 **Confirm the connection to your destination.** (📖50)



\*1 In case the case you use the Subnet mask except Class A/B/C, the screen is appeared. Please set the Subnet mask.

**NOTE** • If you require the network setting information on the projector, take the following procedure to find it out.

- 1) Turn on the projector, and make sure that the projector image is on screen.
- 2) Press the MENU button on the remote control or the ▲/▼/◀/▶ buttons on the projector to show the menu on screen.
- 3) Use the ▲/▼ cursor buttons to select the Advanced Menu, and use the ► cursor button to enter the item.
- 4) Use the ▲/▼ cursor buttons to select the MIU, and use the ► cursor button to enter the item.
- 5) Use the ▲/▼ cursor buttons to select the INFORMATION, and push the ► cursor button.
- 6) The setting will be displayed in the MIU-INFORMATION box.

## 3.5 Manual configuration

There are 3 options for the manual configuration.

- Profile
- History
- Configure Network Settings Manually

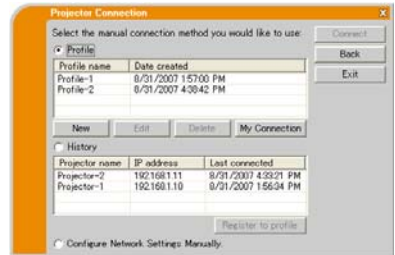

### 3.5.1 Profile connection

Selecting a profile data connect the network with the projector.

It is required to store the profile data in advance. (📖60)

- 1) Select [**Profile**].
- 2) Choose a profile data listed in the window.
- 3) Click [**Connect**].
- 4) The network connection will be established.  
Proceed to the item 3.6 **Confirm the connection to your destination.** (📖50)



**NOTE** • To check the setting in a profile data, follow the process below.

- 1) Choose a profile data that you want to check.
- 2) Move the mouse cursor to the profile data, and click the right button on the mouse to display a pop-up menu.
- 3) Select the “Property” in the pop-up menu, and click the left button on the mouse.
- 4) The setting information of the selected profile data is shown.
  - If the DHCP is set on in the projector, the network connection between the projector and PC may not be established since IP address may be varied. If you like to use the Profile connection, set the DHCP off in the projector.

## 3.5 Manual configuration (continued)

### 3.5.2 History connection

The “Live Viewer 3” can memory the network settings when connecting to the projector as a history record. After that, selecting a history record can quickly connect the network with the projector.

- 1) Select **[History]**.
- 2) Choose a history record listed in the window.
- 3) Click **[Connect]**.
- 4) The network connection will be established.

Proceed to the item 3.6 **Confirm the connection to your destination.** (📖 50)

If you want to copy a history record to a profile data, select one of the history record and click **[Register to profile]**. The profile data cannot be erased automatically.

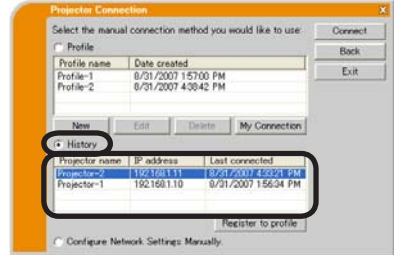

**NOTE** • The number of the history record is maximum 10 for each network adapter. When the 11th data is stored, the oldest record among the 10 will be overwritten.

- The data & time information in each history record is renewed when the network is connected by using the history record.
- If the DHCP is set on in the projector, the network connection between the projector and PC may not be established since IP address may be varied.
- Even if you use the profile connection, it will be memorized as a history record.



### 3.5 Manual configuration (continued)

#### 3.5.3 Configuring manually

All setting for the network connection between the projector and PC is input manually.

Select **[Configure Network Settings Manually]**.

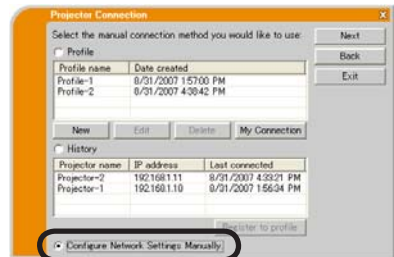

The information to be input manually is different, depending on how you want to connect the projector and PC.

#### Wireless LAN

The required information depends on how you connect the projector and PC.

- Direct connection between the projector and PC (AdHoc mode). (44)
- The projector connected to an access point by a LAN cable. (45)
- The projector connected to an access point by the wireless LAN. (46)

#### Wired LAN

If you use the wired LAN, go to (47).

#### 3.5 Manual configuration (continued)

#### Direct connection between the projector and PC (AdHoc mode)

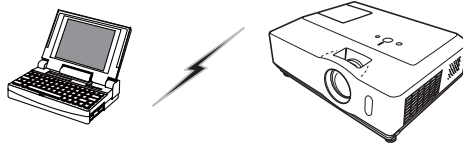

1) Enter the following information that is set in the projector. **\*1**

SSID: wireless (example)  
Encryption: WEP64bit (example)  
Encryption key **\*2**: \*\*\*\*\* (example)  
Mode: ADHOC

Projector Connection

Enter the following information.

SSID : [dropdown]  
Encryption : OFF  
Encryption key : [text field]  
Mode : AD-HOC

Next  
Back  
Exit

Enter the Wireless Projector Configuration information.  
Please refer to the following instruction for wireless setup.  
Menu-Advanced Menu-MIU-Information

2) Click **[Next]**.

3) Enter the following information that is set in the projector. **\*1**

IP Address : 192.168.1.10 (example)  
Subnet mask : 255.255.255.0 (example)

Projector Connection

Enter the following information.

IP address : [text field]  
Subnet mask : [text field]

Connect  
Back  
Exit

Enter Projector IP Address and Subnet mask.

4) Click **[Connect]**.

5) The wireless connection will be established.

Proceed to the item 3.6 **Confirm the connection to your destination.** ([📖 50](#))

**\*1** To find the network setting on the projector, refer to the NOTE. ([📖 40](#))

**\*2** If you use an encryption, you need to set it. Contact the network administrator to find the encryption key that is set in the projector.

The encryption key is always shown as "\*\*\*\*\*".

## 3.5 Manual configuration (continued)

The projector connected to an access point by a LAN cable

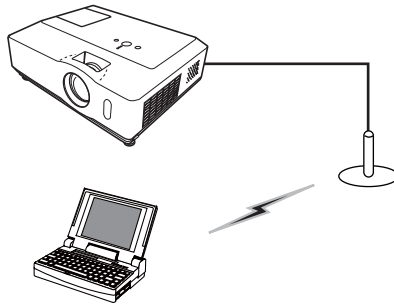

1) The setting on the access point. **\*1**

Enter the following information.

SSID: WirelessAccessPoint (example)  
 Encryption: WEP64bit (example)  
 Encryption key **\*2**: \*\*\*\*\* (example)  
 Mode: INFRASTRUCTURE

The screenshot shows a dialog box titled "Projector Connection" with the following fields and buttons:

- Enter the following information.
- SSID: [WirelessAccessPoint] (dropdown menu)
- Encryption: [OFF] (dropdown menu)
- Encryption key: [\*\*\*\*\*] (text field)
- Mode: [INFRASTRUCTURE] (dropdown menu)
- Buttons: Next, Back, Exit
- Footer: Enter Wireless Access Point Configuration information.

2) Click **[Next]**.

3) Enter the following information that is set in the projector. **\*3**

IP Address : 192.168.1.10 (example)  
 Subnet mask: 255.255.255.0 (example)

The screenshot shows a dialog box titled "Projector Connection" with the following fields and buttons:

- Enter the following information.
- IP address: [192.168.1.10] (text field)
- Subnet mask: [255.255.255.0] (text field)
- Buttons: Connect, Back, Exit
- Footer: Enter Projector IP Address and Subnet mask.

4) Click **[Connect]**.

5) The wireless connection will be established.

Proceed to the item 3.6 **Confirm the connection to your destination.** ([📖50](#))

**\*1** Contact the network administrator to find out the setting on the access point.

**\*2** If you use an encryption, you need to set it. Contact the network administrator to check the encryption key that is set in the projector.

The encryption key is always shown as "\*\*\*\*\*".

**\*3** To find the network setting on the projector, refer to the NOTE. ([📖40](#))

#### 3.5 Manual configuration (continued)

The projector connected to an access point by the wireless LAN

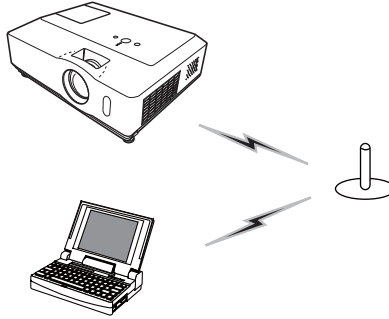

1) The setting on the access point. \*1

Enter the following information.

SSID: WirelessAccessPoint (example)

Encryption: WEP64bit (example)

Encryption key \*2: \*\*\*\*\* (example)

Mode: INFRASTRUCTURE

The screenshot shows a dialog box titled "Projector Connection" with a close button (X) in the top right. It contains the following fields and controls:

- Text: "Enter the following information." with a "Next" button to the right.
- Field: "SSID" with a dropdown arrow.
- Field: "Encryption" with a dropdown menu showing "OFF".
- Field: "Encryption key" with a text input field.
- Field: "Mode" with a dropdown menu showing "INFRASTRUCTURE".
- Buttons: "Back" and "Exit" on the right side.
- Bottom section: "Enter Wireless Access Point Configuration information."

2) Click **[Next]**.

3) Enter the following information that is set in the projector. \*3

IP Address : 192.168.1.10 (example)

Subnet mask: 255.255.255.0 (example)

The screenshot shows a dialog box titled "Projector Connection" with a close button (X) in the top right. It contains the following fields and controls:

- Text: "Enter the following information." with a "Connect" button to the right.
- Field: "IP address" with a text input field.
- Field: "Subnet mask" with a text input field.
- Buttons: "Back" and "Exit" on the right side.
- Bottom section: "Enter Projector IP Address and Subnet mask."

4) Click **[Connect]**.

5) The wireless connection will be established.

Proceed to the item 3.6 **Confirm the connection to your destination.** ([📖 50](#))

\*1 Contact the network administrator to find out the setting on the access point.

\*2 If you use an encryption, you need to set it. Contact the network administrator to check the encryption key that is set in the projector.

The encryption key is always shown as "\*\*\*\*\*".

\*3 To find the network setting on the projector, refer to the NOTE. ([📖 40](#))

### 3.5 Manual configuration (continued)

#### Wired LAN

- 1) Enter the following information for the projector. **\*1**  
 IP Address : 192.168.1.10 (example)  
 Subnet mask : 255.255.255.0 (example)

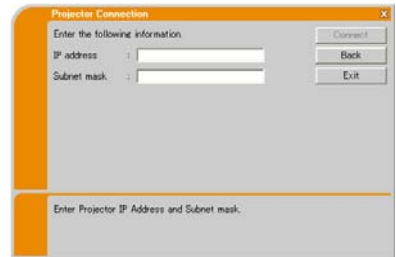

- 2) Click **[Connect]**.
- 3) The network connection will be established.  
 Proceed to the item 3.6 **Confirm the connection to your destination.** (📖50)

**\*1** To find the network setting on the projector, refer to the NOTE. (📖40)

#### [trouble shooting]

- A network connection could not be established.  
 Windows prevented network configuration changes.

You may log in the Windows under User authority.

Click **[OK]**, then the “Live Viewer 3” main menu is displayed even though the network is not established. Click  on the main menu and go back to the item **3.3.3 Connecting to the network.** (📖31)



Consult to the network administrator. Log in the Windows under Administrator authority. After that, please resume at the item **3.3.1 Starting the “Live Viewer 3”.** (📖26)

#### 3.5 Manual configuration (continued)

■ Automatic connection failed.

The reason is that the IP address set in the projector is the global address.

Following the instruction by the network administrator, set the IP address and Subnet mask in the “Live Viewer 3”.

After input these address, click **[Connect]**.

If you want to erase the information you input, click **[Reset]**.

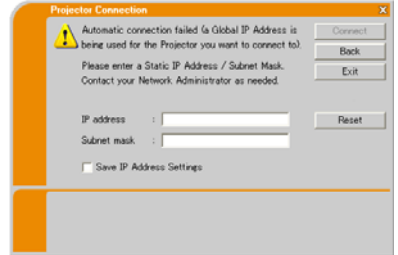



**NOTE** • If the IP address you input to the PC is the same as the one set in the projector, a warning message will come up. Please choose an IP address that is currently not in use.

■ A Network Configuration Conflict exists.

The message comes up when the network connection mode you set in the PC does not match with the mode of the projector.

Please verify your network configuration setting on the projector and PC.

Click **[Exit]**, then the “Live Viewer 3” main menu is displayed even though the network is not established. Click  on the main menu to go back to the item **3.3.3 Connecting to the network.** (31)

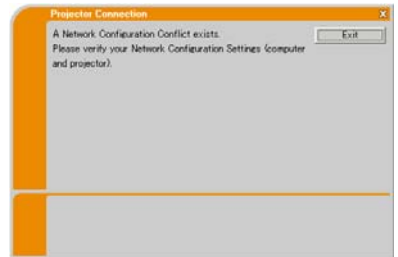

### 3.5 Manual configuration (continued)

#### ■ Are you sure you want to connect the selected projector?

The message is appeared when the wireless adapter you selected is already used for another network connection.

- To connect, click **[Yes]**. Proceed to the 3.6 **Confirm the connection to your destination.** (📖50)
- Not to connect, click **[No]** then the “Live Viewer 3” main menu is displayed even though the network is not established. Click  on the main menu to go back to the item **3.3.3 Connecting to the network.** (📖31)





## 3.6 Confirm the connection to your destination

### 3.6.1 Connection and transmission

When the network connection is established, the “Connection to Projector successful” screen is displayed.

Make sure that the right projector that you want to send your image to is selected, by checking the projector name and IP address shown in the screen.



- To send images to the projector, click **[Yes]**. The transmission will be started. It is required to set the MIU as an input port and select the Live Mode in the MIU Menu in the projector, to display the transmitted images. Refer to the item **3.6.3 Setting the Live Mode**. (📖53)
- Not to send, click **[No]**, then the “Live Viewer 3” main menu is displayed in stand-by mode. (The stand-by mode is the condition that the wireless connection is established, but the images are not transmitted.) The transmission can be started, if you click  or  button on the “Live Viewer 3” main menu.

If you wish to use the current connection setting as a profile data for My Connection, check in the box for **[Register this setting to My Connection]**.

### [trouble shooting]

- This projector is currently in use (Presenting) by another user.

The projector you want to send your images to is occupied by another computer in the Presenter mode.

Click **[OK]**, then the “Live Viewer 3” main menu is displayed in stand-by mode. Retry to send your images, after the Presenter mode is off.

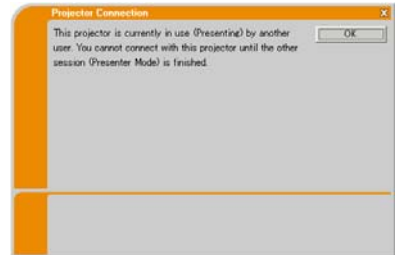



### 3.6 Confirm the connection to your destination (continued)

- A Slideshow is currently running on the projector that you are trying to display to.

The projector you want to send your images to is in the Slide show mode in the PC-LESS Presentation.

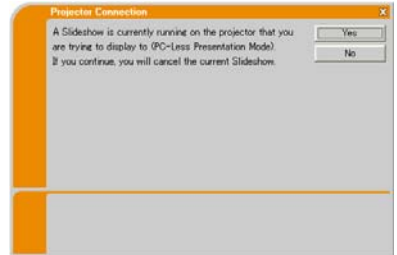

- Click **[Yes]**, then the projector is switched from the Slide show mode to the Live Mode.
- Click **[No]**, then the projector is remained in the Slide show mode, and the “Live Viewer 3” main menu is displayed in stand-by mode on your PC.

- Are you sure you want to switch to Live Mode?

The projector is not set to the Live Mode.



- Click **[Yes]**, then the projector is switched to the Live Mode.
- Click **[No]**, then the projector is remained as it is, and the “Live Viewer 3” main menu is displayed in stand-by mode on your PC.

- Are you sure you want to change the input channel of the Projector to MIU?

The projector is not set to the MIU as an input signal.

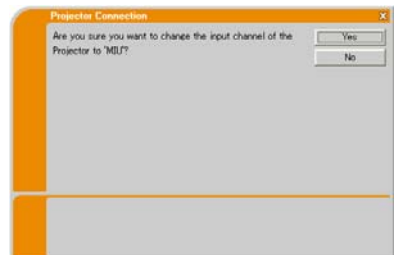



- Click **[Yes]**, then the projector is switched to the MIU.
- Click **[No]**, then the projector is remained as it is, and the “Live Viewer 3” main menu is displayed in stand-by mode on your PC.

## 3.6 Confirm the connection to your destination (continued)

### 3.6.2 Connection error

When the connection to the projector could not be established, an error message, “Network Connection not established”, will come up.

Click **[OK]** then the “Live Viewer 3” main menu is displayed even though the network is not established. Click  on the main menu to go back to the item **3.3.3 Connecting to the network**. ( 31)

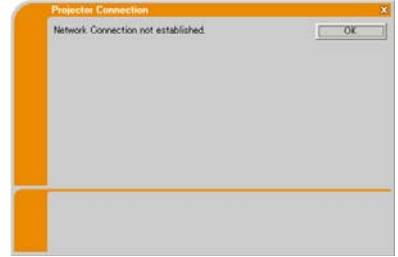

**NOTE** • If you selected the My Connection, the “Live Viewer 3” is closed. Check the network setting in the projector, and retry the connection from the item **3.3 Quick connection to the network**. ( 26)

### [trouble shooting]

- The network connection is refused.

The Projector has already reached the maximum number of Network Connections.

The projector can connect up to 5 PCs at the same time.

Click **[OK]**, then the “Live Viewer 3” main menu is displayed even though the network is not established.

After disconnecting a PC, please retry to connect to the network.

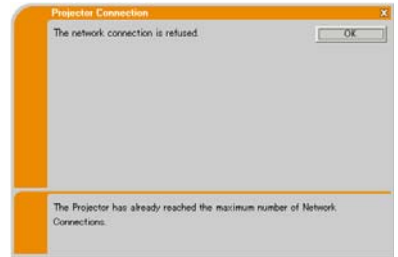

### 3.6 Confirm the connection to your destination (continued)

#### 3.6.3 Setting the Live Mode

This section is intended to explain how to switch to the Live Mode in the MIU on the projector, by using the remote control or a web browser software.

##### from Web Remote Control on a web browser

- 1) Click [LIVE MODE] button.  
(Refer to the item 4.1.11 Remote Control ([📖85](#)))

##### from the OSD menu, by using the remote control or keypad on the projector.

- 1) Turn on the projector, and make sure that the projector image is on screen.
- 2) Press the MENU button on the remote control or the ▲/▼/◀/▶ buttons on the projector to show the menu on screen.
- 3) Use the ▲/▼ cursor buttons to select the Advanced Menu, and use the ▶ cursor button or ENTER button to enter the item.
- 4) Use the ▲/▼ cursor buttons to select the MIU, and use the ▶ cursor button or ENTER button.
- 5) Use the ▲/▼ cursor buttons to select the LIVE MODE, and push the ▶ cursor button or ENTER button.  
(Refer to [📖 MIU Menu in the User's Manual \(detailed\) – Operating Guide](#))

##### from MY BUTTON function

- 1) Turn on the projector, and make sure that the projector image is on screen.
- 2) Press the MENU button on the remote control or the ▲/▼/◀/▶ buttons on the projector to show the menu on screen.
- 3) Use the ▲/▼ cursor buttons to select the Advanced Menu, and use the ▶ cursor button or ENTER button to enter the item.
- 4) Use the ▲/▼ cursor buttons to select the OPTION, and use the ▶ cursor button or ENTER button.
- 5) Use the ▲/▼ cursor buttons to select the MY BUTTON Menu, and use the ▶ cursor button or ENTER button to enter the item.
- 6) Choose 1 or 2 on the MY BUTTON menu using the ◀/▶ cursor buttons.  
Then using the ▲/▼ buttons sets LIVE MODE function to the button.  
(Refer to [📖 OPTION Menu in the User's Manual \(detailed\) – Operating Guide](#))

### 3.7 Start the “Live Viewer 3”

When you get the connection between your projector and PC, the “Live Viewer 3” main menu will be shown on the PC screen.

On the main menu you can configure the settings and operate the functions to send your images to the projector in the Live Mode.

#### 3.7.1 Main menu and Operating buttons

##### 1) Menu Type

There are 2 type of the main menu, Easy type and Advanced type, which can be switched on screen.

- When the “Live Viewer 3” is started, the last used type will be screen.
- When the network connection is not established, the Advanced type will be on screen.

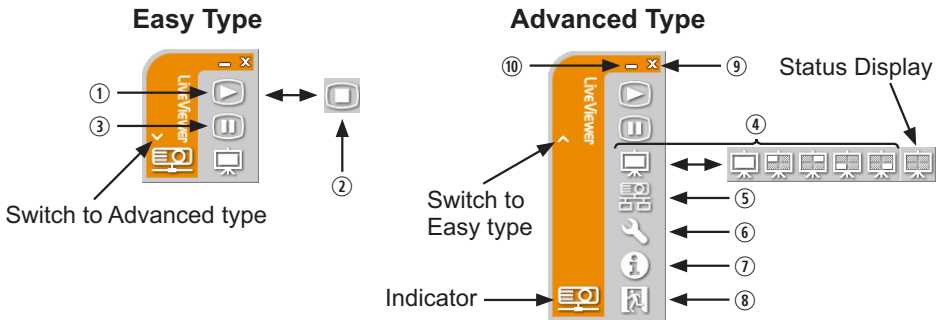

Fig. 3.7.1 a Live Viewer 3 Main menu

##### 2) Operating buttons

###### ① Starting Capture button

The transmission to the projector is started and the images will be displayed in the Live Mode.

The Display mode will be the Single PC mode at first. After that, the last Display mode will be applied.

###### ② Stop button

The image transmission is stopped.

**NOTE** • The images may not be displayed on screen, if the Start/Stop buttons are clicked repeatedly.

### 3.7 Start the “Live Viewer 3” (continued)

③ **Hold button**

The image on screen is temporally frozen.

The last image before the button is clicked is remained on screen.

You can revise the image data on your PC without showing it on the projector’s screen.

④ **Display mode button** (📖57)

The button switches the Single PC mode and Multi PC mode.

⑤ **Connect button**

The screen to select the connection mode is displayed.

Go to the item 3.3.3 (📖31)

⑥ **Option button**

The option screen is displayed.

⑦ **Information button**

The version of the “Live Viewer 3” is displayed.

⑧, ⑨ **Close button**

The network is disconnected and the “Live Viewer 3” is closed.

⑩ **Minimize button**

The main menu is closed, and the “Live Viewer 3” icon is displayed on the task tray in your PC. If the icon is double-clicked, the last type of the main menu will be shown on screen.

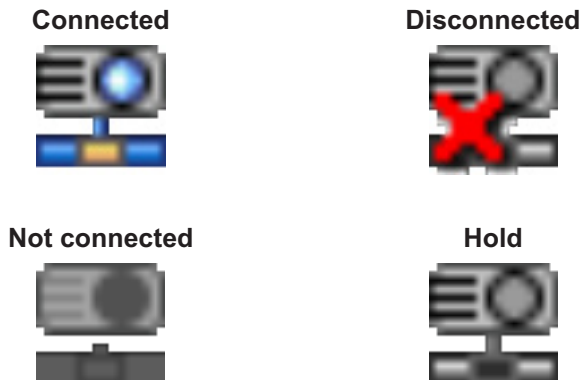





Fig. 3.7.1 b Task tray Icon

### 3.7 Start the “Live Viewer 3” (continued)

#### 3.7.2 Displaying the status

1) Indicator





The indicator shows the following status.

Indicator	Status	Note
	Not connected	The network connection to the projector is not established yet.
	Hold	The network connection is established, but the image transmissions on hold.
	Connected	The network connection is established and the images on the PC are being sent to the projector.
	Disconnected	The network connection to the projector is disconnected.

2) Status Display in Multi PC mode

The icon is displayed at the right end of the Display mode buttons.

One of the following icons to inform which quarter screens are used will be shown.

Status	Status icon
No PC is on screen	
One PC is on screen.	
Two PCs are on screen.	
Three PCs are on screen.	
Four PCs are on screen.	

**NOTE** • The status display is refreshed in every 3 seconds.  
 • If the status cannot be gotten from the projector, it will not be displayed.

### 3.7 Start the “Live Viewer 3” (continued)

#### 3.7.3 Switching the display mode

The “Live Viewer 3” has the Single PC mode and Multi PC mode. The modes can be switched on the main menu.

- 1) Click the  button on the main menu.  
The buttons below are displayed.



- 2) Select from ① to ⑤ buttons, and click it.
  - ① Switching to the Single PC mode : Your image is displayed on full screen.
  - ②-⑤ Switching to the Multi PC mode : Your image is displayed on a quarter screen identified in the button.
- 3) The projector screen is switched to the mode selected above, and the transmission of your PC image will be started to display your image on the screen.
- 4) The icon  on the main menu is replaced by the icon you selected.

**NOTE** • The image transmission will be stopped, when you click the Single mode button while the projector is in the Single PC mode or you click one of the Multi mode buttons that shows the quarter screen which is currently displaying your PC images in the Multi PC mode.

- If the Multi PC mode is selected, the projector screen is automatically divided to 4 zones.
- If the Presenter mode is set on in the PC whose image is currently on screen in the Single PC mode, the  button cannot be clicked on other PCs.
- If the quarter screen that displays images sent from another PC is selected, the network to the PC is disconnected.

(Refer to  the **MIU Menu in the User’s Manual (detailed) – Operating Guide** for the function on the projector.)

## 3.7 Start the “Live Viewer 3” (continued)

### 3.7.4 Option menu

Clicking the Option button displays the option menu on screen.

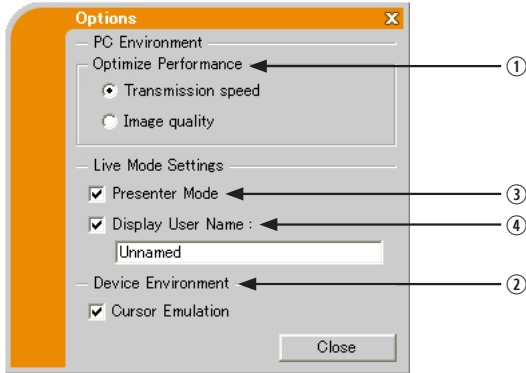

#### ① Optimize Performance

The “Live Viewer 3” captures PC screen in JPEG data and sends the JPEG data to the projector. The “Live Viewer 3” has two options that have different compression rate of JPEG data.

##### Transmission speed

Speed takes priority over Image quality.

It makes JPEG compression rate higher.

The screen on the projector is rewritten quicker because the transferred data is smaller, but the image quality is worse.

##### Image quality

Image quality takes priority over Speed.

It makes JPEG compression rate lower.

The screen on the projector is rewritten slower because the transferred data is larger, but the image quality is better.

#### ② Cursor Emulation

If a mouse cursor (pointer) on your PC screen is not displayed on the projector screen, check in the box. The “Live Viewer3” helps you to find the cursor on the screen. If the cursor is on the projector screen, not check it.



### 3.7 Start the “Live Viewer 3” (continued)

#### ③ Presenter Mode

In the Single PC mode, the projector can be occupied by one PC and can block an access from any other PC, if the Presenter mode is set to on in the “Live Viewer 3”.

While making your presentation, you don’t need to worry that the image on screen is unexpectedly switched to an image sent by another PC.

If you want to turn it on, put a check mark in the check box.

**NOTE** • If the Multi PC mode is selected, the setting for the Presenter mode is invalid.

- When switching from the Multi PC mode to the Single PC mode, the Presenter mode setting of the PC is valid.
- The default setting is on.

#### ④ Display User Name

The user name that is up to 20 letters can be input by using alphanumeric characters.

The user name can be displayed on the projector screen, so you can find out whose image is currently on the screen.

(Refer to  **MIU Menu in the User’s Manual (detailed) – Operating Guide**)

If the check box is not marked, the information is not sent to the projector.

## 3.8 Profile data

### 3.8.1 Outline of Profile data

The network setting to connect the projector and PC can be stored as a profile data. Once the data is stored, all you need to do is to select the data to connect to the network. It is recommended when the same network connection is often used.

### 3.8.2 Making Profile data

The profile data is made on the Manual Configuration screen. (41)  
Up to 10 profile data can be stored for each network adapter.

1) Select **[Profile]** and click **[New]**.



2) The “Create new profile” will come up.  
If you have already made 10 profile data, you cannot make a new one, until you delete a stored data.

Input all information required for your network connection.

If you want to clear the information you input, click **[Clear]**.



3) Click **[OK]**, after all information is set.  
If you don't want to store it, click **[Cancel]**.

4) The new profile data is shown in the profile list, if you click **[OK]**.

**NOTE** • When you make a new profile data, it is strongly recommended to check that the new data can work properly by selecting the data at the Profile connection. (41)  
• If you change a wireless network adapter on the projector or PC, make a new profile data for the adapter.

### 3.8 Profile data (continued)

#### 3.8.3 Editing Profile data

If necessary, the profile data can be edited on the Manual Configuration screen. (41)

- 1) Select **[Profile]**, and select one of the data listed in the window.
- 2) Click **[Edit]**.

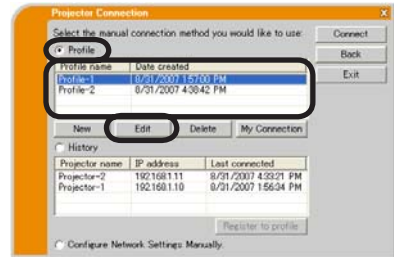

- 3) The “Edit profile” screen will come up.
- 4) Edit the information required to be revised. If you want to clear all information in the window, click **[Clear]**.
- 5) Click **[OK]**, after the editing is completed. If you don't want to store it, click **[Cancel]**.

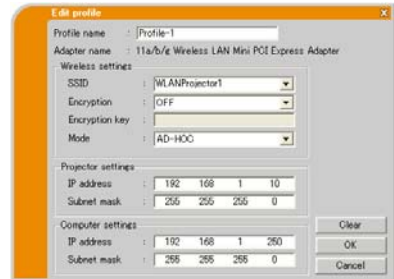

- 6) The edited profile data is stored and shown in the profile list with the new date created information, if you click **[OK]**.

**NOTE** • When you edit a profile data, it is strongly recommended to check that the edited data can work properly by selecting the data at the Profile connection. (41)

## 3.8 Profile data (continued)

### 3.8.4 Registering My Connection

One of the profile data, which is often used, can be registered as the My Connection profile data. Once the data is registered, all you need to do is to select the My Connection to connect to the network. (📖29)

- 1) Click **[My Connection]**.
- 2) The “Add My Connection” screen will come up.  
The currently selected profile data for the My Connection is shown with a check mark in the list.
- 3) Select one of the profile data listed in the window and put a mark in the check box.  
The data selected before is turned unmarked.
- 4) Click **[OK]**, then the window is closed.  
If you don't want to select a new one, click **[Cancel]**.

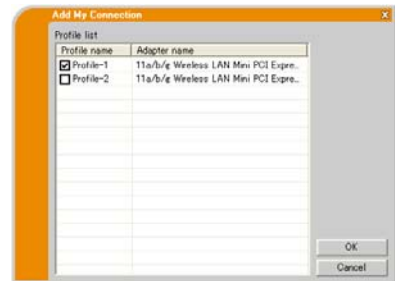

**NOTE** • If you don't want to use the My Connection, mark no data listed in the window, and click **[OK]**.  
• In the list, all profile data are shown no matter which network adapter is selected. You can register a profile data that is not for currently selected network adapter as the My Connection profile data.

### 3.8 Profile data (continued)

Also, you can register a profile data to My Connection, when the network connection is established. When it is established, the “Connection to Projector successful” screen is displayed. (📖50)

If you wish to use the current connection setting for My Connection, check in the box for **[Register this setting to My Connection]**. And then, if it is okay to overwrite the present data for My Connection, click **[OK]**.

A new profile data will be created and it is registered as My Connection profile data.

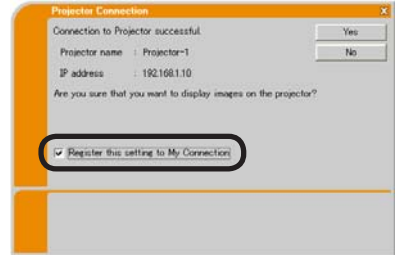

- NOTE**
- If there are already 10 profile data, the check box cannot be checked. Please erase one of the existing profile data.
  - The profile name for the stored data is assigned by the “Live Viewer 3” automatically. The name will be shown at the right side of the check box.

### 4. Management with Web browser software

This projector is equipped with the following network functions by using a web browser software.

#### **Configuring and Controlling the Projector via a Web Browser**

You can change the settings of or control the projector via a network by using a web browser from a PC that is connected to the same network.

(67)

#### **E-mail Alerts**

The projector can automatically send an alert to specified e-mail addresses when the projector requires maintenance or has encountered an error.

(89)

#### **Projector Management using SNMP**

This projector is SNMP (Simple Network Management Protocol) compliant, allowing you to monitor it from a remote location using SNMP software. In addition, the projector is able to send failure & warning alerts to a specified PC.

(91)

#### **Event Scheduling**

You can schedule the projector to perform various functions according to the date and time.

(92)

#### **e-SHOT (Still Image Transfer) Display**

The projector can display still images that are transferred via the network.

(95)

#### **Command Control via the Network**

The projector can be controlled using RS-232C commands over a network.

(96)

## 4.1 Configuring and controlling the projector via a web browser

You can adjust or control the projector via a network from a web browser on a PC that is connected to the same network.

**NOTE** • Internet Explorer 5.5 or later is required.

- If JavaScript is disabled in your web browser configuration, you must enable JavaScript in order to use the projector web pages properly. See the Help files for your web browser for details on how to enable JavaScript.
- It is recommended that all web browser updates are installed. It is especially recommended that all users running Internet Explorer on a Microsoft Windows version prior to Windows XP Service Pack 2 install security update Q832894 (MS04-004) or the web browser interface may not be displayed correctly. And when using an earlier version of Internet Explorer, during operations the browser will log out after 50 seconds.

**4.1 Configuring and controlling the projector via a web browser (Continued)**

When configuring or controlling the projector via a web browser, an ID and password are required. There are two types of IDs, Administrator ID and User ID. The following chart describes the differences between Administrator and User IDs.

Item	Description	Administrator	User
<b>Network Information</b>	Displays the projector's current network configuration settings.	√	√
<b>Network Settings</b>	Displays and configures network settings.	√	N/A
<b>Port Settings</b>	Displays and configures communication port settings.	√	N/A
<b>Mail Settings</b>	Displays and configures e-mail addressing settings.	√	N/A
<b>Alert Settings</b>	Displays and configures failure & warning alerts.	√	N/A
<b>Schedule Settings</b>	Displays and configures schedule settings.	√	N/A
<b>Date/Time Settings</b>	Displays and configures the date and time settings.	√	N/A
<b>Security Settings</b>	Displays and configures passwords and other security settings.	√	N/A
<b>Projector Control</b>	Controls the projector.	√	√
<b>Remote Control</b>	Controls the projector like IR remote.	√	√
<b>Projector Status</b>	Displays and configures the current projector status.	√	√
<b>Network Restart</b>	Restarts the projector's network connection.	√	N/A



4.1 Configuring and controlling the projector via a web browser (Continued)

4.1.1 Logon

Refer to the following for configuring or controlling the projector via a web browser.

**Example:** If the IP address of the projector is set to **192.168.1.10**:

- 1) Enter “**http://192.168.1.10**” into the address bar of the web browser and press “Enter” key or click “Go” button. The screen in Fig. 4.1.1a will be displayed.
- 2) Enter your ID and password and click **[Logon]**.

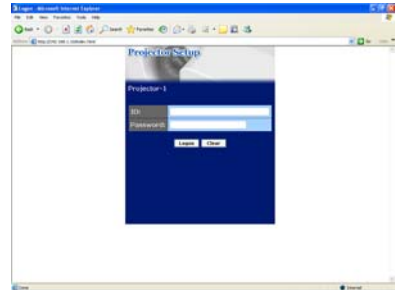

Fig. 4.1.1 a “Logon Menu”

Below are the factory default settings for administrator ID, user ID and passwords.

Item	ID	Password
Administrator	Administrator	<blank>
User	User	<blank>

If the logon is successful, either the Fig. 4.1.1 b or Fig. 4.1.1 c screen will be displayed.

Main menu

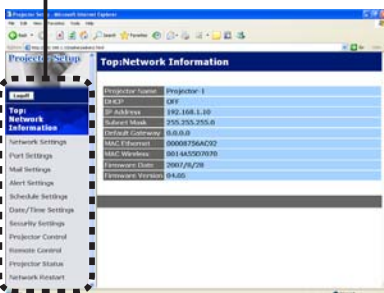

Fig. 4.1.1 b “Logon with Administrator ID”

Main menu

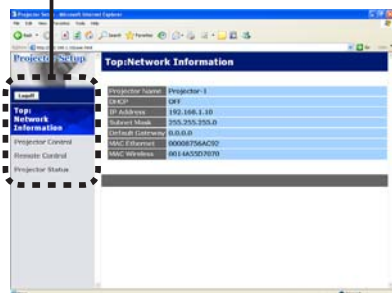
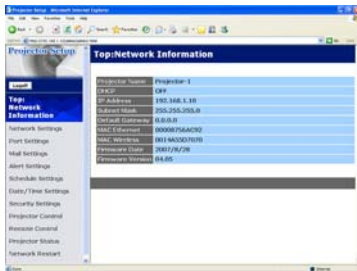

Fig. 4.1.1 c “Logon with User ID”

- 3) Click the desired operation or configuration item on the main menu located on the left-hand side of the screen.

4.1 Configuring and controlling the projector via a web browser (Continued)

4.1.2 Network Information



All screen drawings in this manual are shown when you logon with the Administrator ID. Any functions that are available only for the Administrator will not be shown when you logon with the User ID. Refer to the table. (66)

Displays the projector's current network configuration settings.

Item	Description
<b>Projector Name</b>	Displays the projector name settings.
<b>DHCP</b>	Displays the DHCP configuration settings.
<b>IP Address</b>	Displays the current IP address.
<b>Subnet Mask</b>	Displays the subnet mask.
<b>Default Gateway</b>	Displays the default gateway.
<b>MAC Ethernet</b>	Displays the ethernet MAC address.
<b>MAC Wireless</b>	Displays the wireless LAN MAC address.  <b>NOTE</b> • MAC wireless will not be displayed when the NETWORK MODE is set to the WIRED even if the wireless network card is mounted. (MIU Menu in the User's Manual (detailed)) – Operating Guide)
<b>Firmware Date</b>	Displays the network firmware time stamp. This information is only displayed when logged on using an Administrator ID.
<b>Firmware Version</b>	Displays the network firmware version number. This information is only displayed when logged on using an Administrator ID.

## 4.1 Configuring and controlling the projector via a web browser (Continued)

### 4.1.3 Network Settings

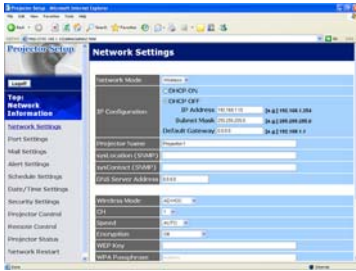

Displays and configures network settings.

Item	Description
<b>Network Mode</b>	Select Network mode “Wired” or “Wireless”.
<b>IP Configuration</b>	Configures network settings.
<b>DHCP ON</b>	Enables DHCP.
<b>DHCP OFF</b>	Disables DHCP.
<b>IP Address</b>	Configures the IP address when DHCP is disabled.
<b>Subnet Mask</b>	Configures the subnet mask when DHCP is disabled.
<b>Default Gateway</b>	Configures the default gateway when DHCP is disabled.
<b>Projector Name</b>	Configures the name of the projector. The length of the Projector Name can be up to 64 alphanumeric characters. Only alphabets, numbers and following symbols can be used. !"#\$\$%&'()*+,-./:;<=>?@[\\]^_`{ }~ and space
<b>sysLocation (SNMP)</b>	Configures the location to be referred to when using SNMP. The length of the sysLocation can be up to 255 alphanumeric characters. Only numbers '0-9' and alphabet 'a-z', 'A-Z' can be used.
<b>sysContact (SNMP)</b>	Configures the contact information to be referred to when using SNMP. The length of the sysContact can be up to 255 alphanumeric characters. Only numbers '0-9' and alphabet 'a-z', 'A-Z' can be used.
<b>DNS Server Address</b>	Configures the DNS server address.

## 4.1 Configuring and controlling the projector via a web browser (Continued)

Item	Description
Wireless Mode	Select "AD-HOC" or "Infrastructure".
CH (Communication channel)	Select using channel between "1" and "11". <b>NOTE</b> • Depending on the country where you are the channels may vary. In addition, depending on the country or region where you are may be required to use a wireless network card that confirm to the standards in the respective country or region.
Speed (Communication speed)	Select communication speed.
Encryption	Select data encryption method.
WEP Key	Input WEP key, which has same length defined by WEP. When "64bit" or "128bit" is selected, input 10 characters or 26 characters respectively. Only numbers from "0" to "9" and alphabets from "a" to "f" (whichever small or capital characters) can be used. Enter the series of two characters pair. It will be cleared by 0, if the total length is odd.
WPA Passphrase	Input WPA Passphrase. Available number of input characters is 8 to 63. Only alphabets, numbers and following symbols can be used. !"#\$%&'()*+,-./:;<=>?@[ ]^_`{ }~ and space
SSID	Select an SSID from the list. If you require to set your unique SSID, select <b>[Custom]</b> , then set your own SSID following the rules below. Maximum number of input characters is 32. Only alphabets, numbers and following symbols can be used. !"#\$%&'()*+,-./:;<=>?@[ ]^_`{ }~ and space.

Click **[Apply]** button to save the settings.

**NOTE** • The new configuration settings are activated after restarting the network connection. When the configuration settings are changed, you must restart the network connection. You can restart the network connection by clicking **[Network Restart]** on the main menu.

- If you connect the projector to an existing network, consult a network administrator before setting server addresses.
- The WEP Key, WPA passphrase and SSID settings will not be set if the invalid characters are used.

## 4.1 Configuring and controlling the projector via a web browser (Continued)

### 4.1.4 Port Settings

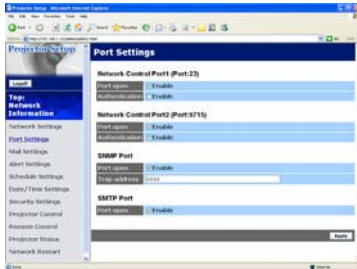

Displays and configures communication port settings.

Item	Description
<b>Network Control Port1 (Port:23)</b>	Configures command control port 1 (Port:23).
Port open	Click <b>[Enable]</b> check box to use port 23.
Authentication	Click <b>[Enable]</b> check box when authentication is required for this port.
<b>Network Control Port2 (Port:9715)</b>	Configures command control port 2 (Port:9715).
Port open	Click <b>[Enable]</b> check box to use port 9715.
Authentication	Click <b>[Enable]</b> check box when authentication is required for this port.
<b>SNMP Port</b>	Configures the SNMP port.
Port open	Click <b>[Enable]</b> check box to use SNMP.
Trap address	Configures the destination of the SNMP Trap in IP format.
<b>SMTP Port</b>	Configures the SMTP port.
Port open	Click <b>[Enable]</b> check box to use the e-mail function.

Click **[Apply]** button to save the settings.

## 4.1 Configuring and controlling the projector via a web browser (Continued)

### 4.1.5 Mail Settings

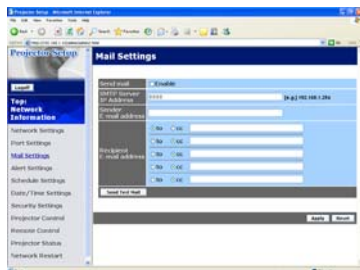

Displays and configures e-mail addressing settings.

Item	Description
<b>Send mail</b>	Click <b>[Enable]</b> check box to use the e-mail function. Configure the conditions for sending e-mail under the Alert Settings.
<b>SMTP Server IP Address</b>	Configures the address of the mail server in IP format. • The address allows not only IP address but also domain name if the valid DNS server is setup in the <b>Network Settings</b> . The maximum length of host or domain name is up to 255 characters.
<b>Sender E-mail address</b>	Configures the sender e-mail address. The length of the sender e-mail address can be up to 255 alphanumeric characters.
<b>Recipient E-mail address</b>	Configures the e-mail address of up to five recipients. You can also specify <b>[TO]</b> or <b>[CC]</b> for each address. The length of the recipient e-mail address can be up to 255 alphanumeric characters.

Click **[Apply]** button to save the settings.

**NOTE** • You can confirm whether the mail settings work correctly using **[Send Test Mail]** button. Please enable Send mail setting before clicking **[Send Test Mail]**.

• If you connect the projector to an existing network, consult a network administrator before setting server addresses.

## 4.1 Configuring and controlling the projector via a web browser (Continued)

### 4.1.6 Alert Settings

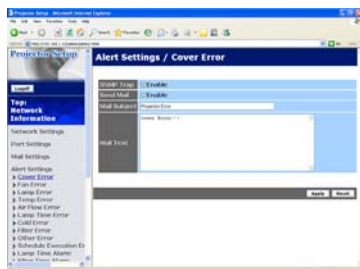

Displays and configures failure & alert settings.

Alert Item	Description
Cover Error	The lamp cover has not been properly fixed.
Fan Error	The cooling fan is not operating.
Lamp Error	The lamp does not light, and there is a possibility that interior portion has become heated.
Temp Error	There is a possibility that the interior portion has become heated.
Air Flow Error	The internal temperature is rising.
Lamp Time Error	Lamp time over.
Cold Error	There is a possibility that the interior portion has become overcooled.
Filter Error	Filter time over.
Other Error	Other error. If displaying this error, please contact your dealer.
Schedule Execution Error	Schedule Execution error. (📖75)
Lamp Time Alarm	Lamp time over Alarm Time setting.
Filter Time Alarm	Filter time over Alarm Time setting.
Transition Detector Alarm	Transition Detector Alarm. (📖OPTION Menu in the User's Manual (detailed) – Operating Guide)
“CHANGE THE LAMP” is displayed.	“CHANGE THE LAMP” is displayed.
Cold Start	The Power switch is turned on. (Off → standby mode)
Authentication Failure	The SNMP access is detected from the invalid SNMP community.

Refer to **“Troubleshooting” in the User’s Manual (detailed) – Operating Guide** for further detailed explanation of Error except Other Error and Schedule Execution Error.

### 4.1 Configuring and controlling the projector via a web browser (Continued)

The Alert Items are shown below.

Setting Item	Description
<b>Alarm Time</b>	Configures the time to alert. (Only Lamp Time Alarm and Filter Time Alarm.)
<b>SNMP Trap</b>	Click <b>[Enable]</b> check box to enable SNMP Trap alerts.
<b>Send Mail</b>	Click <b>[Enable]</b> check box to enable e-mail alerts. (Except <b>Cold Start</b> and <b>Authentication Failure</b> .)
<b>Mail Subject</b>	Configures the subject line of the e-mail to be sent. The length of the subject line can be up to 255 alphanumeric characters. (Except <b>Cold Start</b> and <b>Authentication Failure</b> .)
<b>Mail Text</b>	Configures the text of the e-mail to be sent. The length of the text can be up to 1024 alphanumeric characters. (Except <b>Cold Start</b> and <b>Authentication Failure</b> .)

Click **[Apply]** button to save the settings.

**NOTE** • The trigger of Filter Error e-mail is depending on the FILTER MESSAGE setting in the SERVICE item of the OPTION menu which defines the period until the filter message is displayed on the projector screen. The e-mail will be sent when the filter timer exceeds 50, 100, 200, 300, 400, 500, 600, 700 or 800 hours based on the configuration. No notification e-mail will be sent if the FILTER MESSAGE is set to TURN OFF. ([📖](#) **OPTION Menu in the User's Manual (detailed) – Operating Guide**)

- Lamp Time Alarm is defined as a threshold for e-mail notification (reminder) of the lamp timer. When the lamp hour exceeds this threshold that is configured through the Web page, the e-mail will be sent out.
- Filter Time Alarm is defined as a threshold for e-mail notification (reminder) of the filter timer. When the filter hour exceeds this threshold, the e-mail will be sent out.



## 4.1 Configuring and controlling the projector via a web browser (Continued)

## 4.1.7 Schedule Settings

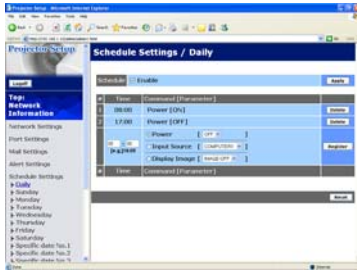

Displays and configures schedule settings.

Item	Description
<b>Daily</b>	Configures the daily schedule.
<b>Sunday</b>	Configures the Sunday schedule.
<b>Monday</b>	Configures the Monday schedule.
<b>Tuesday</b>	Configures the Tuesday schedule.
<b>Wednesday</b>	Configures the Wednesday schedule.
<b>Thursday</b>	Configures the Thursday schedule.
<b>Friday</b>	Configures the Friday schedule.
<b>Saturday</b>	Configures the Saturday schedule.
<b>Specific date No.1</b>	Configures the specific date (No.1) schedule.
<b>Specific date No.2</b>	Configures the specific date (No.2) schedule.
<b>Specific date No.3</b>	Configures the specific date (No.3) schedule.
<b>Specific date No.4</b>	Configures the specific date (No.4) schedule.
<b>Specific date No.5</b>	Configures the specific date (No.5) schedule.

### 4.1 Configuring and controlling the projector via a web browser (Continued)

The daily and weekly event items are shown below.

Item	Daily & Weekly Description
<b>Schedule</b>	Click <b>[Enable]</b> check box to enable the schedule.
<b>Schedule List</b>	Displays the current schedule.

The specific date event items are shown below.

Item	Specific date (No.1-5) Description
<b>Schedule</b>	Click <b>[Enable]</b> check box to enable specific date (No.1-5) schedule.
<b>Date (Month/Day)</b>	Configures the month and date.
<b>Schedule List</b>	Displays the current specific date (No.1-5) schedule.

Click **[Apply]** button to save the settings.

To add additional functions and events, click **[Add]** button and set the following items.

Item	Description
<b>Time</b>	Configures the time to execute commands.
<b>Command [Parameter]</b>	Configures the commands to be executed.
<b>Power</b>	Configures the parameters for power control.
<b>Input Source</b>	Configures the parameters for input switching.
<b>Display Image</b>	Configures the parameters for display of transfer image data.

Click **[Register]** button to add new commands to the Schedule List.

Click **[Delete]** button to delete commands from the Schedule List.

Click **[Reset]** button to delete all commands from the Schedule List.

## 4.1 Configuring and controlling the projector via a web browser (Continued)

## 4.1.8 Date/Time Settings

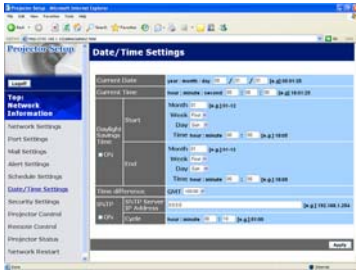

Displays and configures the date and time settings.

Item	Description				
<b>Current Date</b>	Configures the current date in <b>year/month/day</b> format.				
<b>Current Time</b>	Configures the current time in <b>hour:minute:second</b> format.				
<b>Daylight Savings Time</b>	Click <b>[ON]</b> check box to enable daylight savings time and set the following items.				
<b>Start</b>	Configures the date and time daylight savings time begins.				
<b>Month</b>	Configures the month daylight savings time begins (1~12).				
<b>Week</b>	Configures the week of the month daylight savings time begins (First, 2, 3, 4, Last).				
<b>Day</b>	Configures the day of the week daylight savings time begins (Sun, Mon, Tue, Wed, Thu, Fri, Sat).				
<b>Time</b>	<table border="1"> <tr> <td><b>hour</b></td> <td>Configures the hour daylight savings time begins (0 ~ 23).</td> </tr> <tr> <td><b>minute</b></td> <td>Configures the minute daylight savings time begins (0 ~ 59).</td> </tr> </table>	<b>hour</b>	Configures the hour daylight savings time begins (0 ~ 23).	<b>minute</b>	Configures the minute daylight savings time begins (0 ~ 59).
<b>hour</b>	Configures the hour daylight savings time begins (0 ~ 23).				
<b>minute</b>	Configures the minute daylight savings time begins (0 ~ 59).				
<b>End</b>	Configures the date and time daylight savings time ends.				
<b>Month</b>	Configures the month daylight savings time ends (1 ~ 12).				
<b>Week</b>	Configures the week of the month daylight savings time ends (First, 2, 3, 4, Last).				
<b>Day</b>	Configures the day of the week daylight savings time ends (Sun, Mon, Tue, Wed, Thu, Fri, Sat).				
<b>Time</b>	<table border="1"> <tr> <td><b>hour</b></td> <td>Configures the hour daylight savings time ends (0 ~ 23).</td> </tr> <tr> <td><b>minute</b></td> <td>Configures the minute daylight savings time ends (0 ~ 59).</td> </tr> </table>	<b>hour</b>	Configures the hour daylight savings time ends (0 ~ 23).	<b>minute</b>	Configures the minute daylight savings time ends (0 ~ 59).
<b>hour</b>	Configures the hour daylight savings time ends (0 ~ 23).				
<b>minute</b>	Configures the minute daylight savings time ends (0 ~ 59).				

4.1 Configuring and controlling the projector via a web browser (Continued)

Item	Description
<b>Time difference</b>	Configures the time difference. Set the same time difference as the one set on your PC. If unsure, consult your IT manager.
<b>SNTP</b>	Click the <b>[ON]</b> check box to retrieve Date and Time information from the SNTP server and set the following items.
<b>SNTP Server IP Address</b>	Configures the SNTP server address in IP format. • The address allows not only IP address but also domain name if the valid DNS server is setup in the <b>Network Settings</b> . The maximum length of host or domain name is up to 255 characters.
<b>Cycle</b>	Configures the interval at which to retrieve Date and Time information from the SNTP server ( <b>hours:minutes</b> ).

Click **[Apply]** button to save the settings.

**NOTE** • If you connect the projector to an existing network, consult a network administrator before setting server addresses.

- To enable the SNTP function, the time difference must be set.
- The projector will retrieve Date and Time information from the time server and override time settings when SNTP is enabled.
- The internal clock's time may not remain accurate. Using SNTP is recommended to maintain accurate time.

## 4.1 Configuring and controlling the projector via a web browser (Continued)

### 4.1.9 Security Settings

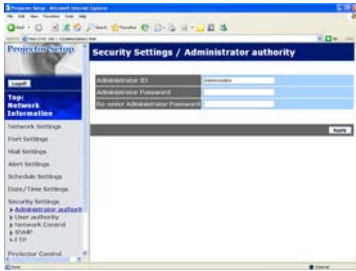

Displays and configures passwords and other security settings.

Item	Description
<b>Administrator authority</b>	Configures the Administrator ID and password.
<b>Administrator ID</b>	Configures the Administrator ID. The length of the text can be up to 32 alphanumeric characters.
<b>Administrator Password</b>	Configures the Administrator password. The length of the text can be up to 255 alphanumeric characters.
<b>Re-enter Administrator Password</b>	Reenter the above password for verification.
<b>User authority</b>	Configures the User ID and password.
<b>User ID</b>	Configures the User ID. The length of the text can be up to 32 alphanumeric characters.
<b>User Password</b>	Configures the User password. The length of the text can be up to 255 alphanumeric characters.
<b>Re-enter User Password</b>	Reenter the above password for verification.

**4.1 Configuring and controlling the projector via a web browser (Continued)**

Item	Description
<b>Network Control</b>	Configures the Authentication password for the command control.
<b>Authentication Password</b>	Configures the Authentication password. The length of the text can be up to 32 alphanumeric characters.
<b>Re-enter Authentication Password</b>	Reenter the above password for verification.
<b>SNMP</b>	Configures the community name if SNMP is used.
<b>Community name</b>	Configures the community name. The length of the text can be up to 64 alphanumeric characters.
<b>FTP</b>	Configures the FTP user and password.
<b>User</b>	Configures the user name. The length of the text can be up to 32 alphanumeric characters.
<b>Password</b>	Configures the password. The length of the text can be up to 32 alphanumeric characters.
<b>Re-enter Password</b>	Reenter the above password for verification.

Click **[Apply]** button to save the settings.

**NOTE** • Only numbers '0-9' and alphabet 'a-z', 'A-Z' can be used.

## 4.1 Configuring and controlling the projector via a web browser (Continued)

### 4.1.10 Projector Control

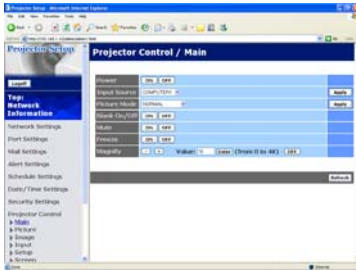

The items shown in the table below can be performed using the Projector Control menu. Select an item using the up and down arrow keys on the PC.

Most of the items have a submenu. Refer to the table below for details.

**NOTE** • The setting value may not match with the actual value if the user changes the value manually. In that case, please refresh the page by clicking [Refresh] button.

Controls the projector.

Item	Description
<b>Main</b>	
<b>Power</b>	Turns the power on/off.
<b>Input Source</b>	Selects the input source.
<b>Picture Mode</b>	Selects the picture mode setting.
<b>Blank On/Off</b>	Turns Blank on/off.
<b>Mute</b>	Turns Mute on/off.
<b>Freeze</b>	Turns Freeze on/off.
<b>Magnify</b>	Controls the magnify setting. In some input signal sources, it might stop "Magnify" even though it does not reach to maximum setting value. The variable range: <ul style="list-style-type: none"> <li>• For a Computer, or MIU signal 0-48</li> <li>• For a video, component or s-video signal 0-16</li> </ul>
<b>Picture</b>	
<b>Brightness</b>	Adjusts the brightness setting.
<b>Contrast</b>	Adjusts the contrast setting.
<b>Gamma</b>	Selects the gamma setting.
<b>Color Temp</b>	Selects the color temperature setting.
<b>Color</b>	Adjusts the color setting.
<b>Tint</b>	Adjusts the tint setting.
<b>Sharpness</b>	Adjusts the sharpness setting.
<b>MyMemory Save</b>	Saves the MyMemory data.
<b>MyMemory Recall</b>	Recalls the MyMemory data.

## 4.1 Configuring and controlling the projector via a web browser (Continued)

Item	Description
<b>Image</b>	
<b>Aspect</b>	Selects the aspect setting.
<b>Over Scan</b>	Adjusts the over scan setting.
<b>V Position</b>	Adjusts the vertical position.
<b>H Position</b>	Adjusts the horizontal position.
<b>H Phase</b>	Adjusts the horizontal phase.
<b>H Size</b>	Adjusts the horizontal size.
<b>Auto Adjust Execute</b>	Performs the automatic adjustment.
<b>Input</b>	
<b>Progressive</b>	Selects the progressive setting.
<b>Video NR</b>	Selects the video noise reduction setting.
<b>Color Space</b>	Selects the color space.
<b>Component</b>	Selects the component terminal setting.
<b>C-Video Format</b>	Selects the video format setting.
<b>S-Video Format</b>	Selects the s-video format setting.
<b>Frame Lock-Computer1</b>	Turns the frame lock-Computer1 function on/off.
<b>Frame Lock-Computer2</b>	Turns the frame lock-Computer2 function on/off.
<b>Computer in-1</b>	Selects the Computer1 input signal type.
<b>Computer in-2</b>	Selects the Computer2 input signal type.
<b>Setup</b>	
<b>Auto Keystone Execute</b>	Performs the automatic keystone distortion correction.
<b>Keystone V</b>	Adjusts the vertical keystone distortion setting.
<b>Whisper</b>	Selects the whisper mode.
<b>Mirror</b>	Selects the mirror status.



## 4.1 Configuring and controlling the projector via a web browser (Continued)

Item	Description
<b>Volume</b>	Adjusts the volume setting.
<b>Speaker</b>	Turns the built-in speaker on/off.
<b>Audio-Computer1</b>	Assigns the AUDIO-COMPUTER IN1 input port.
<b>Audio-Computer2</b>	Assigns the AUDIO-COMPUTER IN2 input port.
<b>Audio-Video</b>	Assigns the AUDIO-VIDEO input port.
<b>Audio-S-Video</b>	Assigns the AUDIO-S-VIDEO input port.
<b>Audio-Component</b>	Assigns the AUDIO-COMPONENT input port.
<b>Audio-MIU</b>	Assigns the AUDIO-MIU input port.
<b>Screen</b>	
<b>Language</b>	Selects the language for the OSD.
<b>Menu Position V</b>	Adjusts the vertical Menu position.
<b>Menu Position H</b>	Adjusts the horizontal Menu position.
<b>Blank</b>	Selects the Blank mode.
<b>Startup</b>	Selects the startup screen mode.
<b>MyScreen Lock</b>	Turns MyScreen lock function on/off.
<b>Message</b>	Turns the message function on/off.
<b>Option</b>	
<b>Auto Search</b>	Turns the automatic signal search function on/off.
<b>Auto Keystone</b>	Turns the automatic keystone distortion correction function on/off.
<b>Auto on</b>	Turns the auto on function on/off.
<b>Auto off</b>	Configures the timer to shut off the projector when no signal is detected.
<b>My Button-1</b>	Assigns the functions for the MY BUTTON1 buttons on the included remote control.
<b>My Button-2</b>	Assigns the functions for the MY BUTTON2 buttons on the included remote control.
<b>Remote Freq. Normal</b>	Enables/Disables the remote control signal frequency normal.
<b>Remote Freq. High</b>	Enables/Disables the remote control signal frequency high.
<b>Close Caption</b>	
<b>Display</b>	Selects Closed Caption DISPLAY setting.
<b>Mode</b>	Selects Closed Caption MODE setting.
<b>Channel</b>	Selects Closed Caption CHANNEL setting.

## 4. Management with Web browser software

### 4.1 Configuring and controlling the projector via a web browser (Continued)

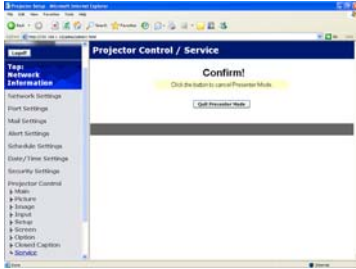

The **Service** item in the **Projector Control** menu is shown only when you logon with the Administrator ID.

The items shown in the table below can be performed using the **Projector Control** menu. Click [**Quit Presenter Mode**].

Item	Description
<b>Service</b>	
<b>Quit Presenter Mode</b>	Quit compulsorily from the Presenter mode.

## 4.1 Configuring and controlling the projector via a web browser (Continued)

### 4.1.11 Remote Control

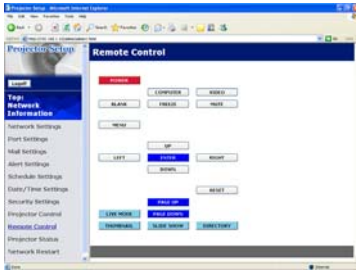

You can use your Web browser to control the projector.

- Do not attempt to control the projector with the projector's remote control and via your Web browser at the same time. It may cause some operational errors in the projector.

The functions on the bundled remote control are assigned to the Web Remote Control screen.

Item	Description
<b>POWER</b>	Assigned the same operation as POWER button.
<b>COMPUTER</b>	Assigned the same operation as COMPUTER button.
<b>VIDEO</b>	Assigned the same operation as VIDEO button.
<b>BLANK</b>	Assigned the same operation as BLANK button.
<b>FREEZE</b>	Assigned the same operation as FREEZE button.
<b>MUTE</b>	Assigned the same operation as MUTE button.
<b>MENU</b>	Assigned the same operation as MENU button.
<b>UP</b>	Assigned the same operation as ▲ button.
<b>DOWN</b>	Assigned the same operation as ▼ button.
<b>LEFT</b>	Assigned the same operation as ◀ button.
<b>RIGHT</b>	Assigned the same operation as ▶ button.
<b>ENTER</b>	Assigned the same operation as ENTER button.
<b>RESET</b>	Assigned the same operation as RESET button.
<b>PAGE UP</b>	Assigned the same operation as PAGE UP button.
<b>PAGE DOWN</b>	Assigned the same operation as PAGE DOWN button.

**4.1 Configuring and controlling the projector via a web browser (Continued)**

The functions on PC-LESS PRESENTATION menu are assigned to the Web Remote Control screen.

Item	Description
<b>LIVE MODE</b>	Selecting this item sets the projector onto the "Live Mode".
<b>THUMBNAIL</b>	Selecting this item sets the projector onto the "Thumbnail mode".
<b>SLIDE SHOW</b>	Selecting this item sets the projector onto the "Slide Show mode".
<b>DIRECTORY</b>	Selecting this item sets the projector onto the "Directory mode".

**NOTE** • The Web Remote Control does not support repeat function that performs an action while holding a button clicked down.

- Since the repeat function is not available, click the button repeatedly as many times as you require.
- Even if you hold the button clicked down for a while, the Web Remote Control sends your request command one time only. Release the button, then click it again.
- When **[POWER]** button is pushed, a message window comes up to confirm the operation. If you wish to turn it off, push **[OK]**, otherwise push **[CANCEL]**.
- **[PAGE DOWN]** and **[PAGE UP]** buttons on the Web Remote Control cannot be used as mouse emulation function of the projector.

## 4.1 Configuring and controlling the projector via a web browser (Continued)

## 4.1.12 Projector Status

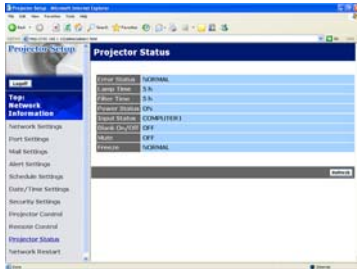

Displays and configures the current projector status.

Item	Description
<b>Error Status</b>	Displays the current error status
<b>Lamp Time</b>	Displays the usage time for the current lamp.
<b>Filter Time</b>	Displays the usage time for the current filter.
<b>Power Status</b>	Displays the current power status.
<b>Input Status</b>	Displays the current input signal source.
<b>Blank On/Off</b>	Displays the current Blank on/off status.
<b>Mute</b>	Displays the current Mute on/off status.
<b>Freeze</b>	Displays the current Freeze status.

### 4.1 Configuring and controlling the projector via a web browser (Continued)

#### 4.1.13 Network Restart

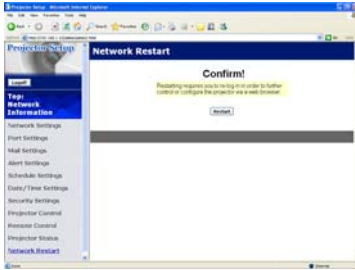

Restarts the projector's network connection.

Item	Description
Restart	Restarts the projector's network connection in order to activate new configuration settings.

**NOTE** • Restarting requires you to re-log on in order to further control or configure the projector via a web browser. Wait 10 seconds or more after clicking **[Restart]** button to log on again.

- The Logon menu ([📖67](#)) is displayed after restarting the projector's network connection if the DHCP is set to ON.

#### 4.1.14 Logoff

When **[Logoff]** is clicked, the Logon menu is displayed ([📖67](#)).

## 4.2 E-mail Alerts

The projector can automatically send an alert message to the specified e-mail addresses when the projector detects a certain condition that is requiring maintenance or detected an error.

**NOTE** • Up to five e-mail addresses can be specified.  
 • The projector may be not able to send e-mail if the projector suddenly loses power.

### Mail Settings (📖72)

To use the projector's e-mail alert function, please configure the following items through a web browser.

Example: If the IP address of the projector is set to 192.168.1.10:

- 1) Enter “**http://192.168.1.10/**” into the address bar of the web browser.
- 2) Enter the Administrator ID and password and click [**Logon**].
- 3) Click [**Port Settings**] on the main menu.
- 4) Click [**Enable**] check box to open the SMTP Port.
- 5) Click [**Apply**] button to save the settings.
- 6) Click [**Mail Settings**] and configure each item. Refer to **the item 4.1.5 Mail Settings (📖72)** for further information.
- 7) Click [**Apply**] button to save the settings.

**NOTE** • Click [**Send Test Mail**] button in [**Mail Settings**] to confirm that the e-mail settings are correct. The following mail will be delivered to the specified addresses.

Subject line	:Test Mail	<Projector name>
Text	:Send Test Mail	
	Date	<Testing date>
	Time	<Testing time>
	IP Address	<Projector IP address>
	MAC Address	<Projector MAC address>

### 4.2 E-mail Alerts (Continued)

- 8) Click **[Alert Settings]** on the main menu to configure the E-mail Alerts settings.
- 9) Select and configure each alert item. Refer to the item 4.1.6 Alert Setting (📖73) for further information.
- 10) Click **[Apply]** button to save the settings.

Failure/Warning e-mails are formatted as follows:

Subject line	: <Mail title>	<Projector name>
Text	: <Mail text>	
	Date	<Failure/Warning date>
	Time	<Failure/Warning time>
	IP Address	<Projector IP address>
	MAC Address	<Projector MAC address>



### 4.3 Projector Management using SNMP

The SNMP (Simple Network Management Protocol) enables to manage the projector information, which is a failure or warning status, from the computer on the network. The SNMP management software will be required on the computer to use this function.

**NOTE** • It is recommended that SNMP functions be carried out by a network administrator.  
• SNMP management software must be installed on the computer to monitor the projector via SNMP.

#### SNMP Settings (📖71)

Configure the following items via a web browser to use SNMP.

Example: If the IP address of the projector is set to 192.168.1.10:

- 1) Enter “**http://192.168.1.10/**” into the address bar of the web browser.
- 2) Enter the Administrator ID and Password and click [**Logon**].
- 3) Click [**Port Settings**] on the main menu.
- 4) Click [**Enable**] check box to open the **SNMP Port**. Set the IP address to send the SNMP trap to when a Failure/Warning occurs.
- 5) Click [**Security Settings**] on the main menu.
- 6) Click [**SNMP**] and set the community name on the screen that is displayed.
- 7) Configure the settings for Trap transmission of Failures/Warnings. Click [**Alert Settings**] on the main menu and select the Failure/Warning item to be configured.
- 8) Click [**Enable**] check box to send out the SNMP trap for Failures/Warnings. Clear [**Enable**] check box when SNMP trap transmission is not required.
- 9) Click [**Apply**] button to save the settings.

## 4.4 Event Scheduling

The scheduling function enables to setup scheduled events including power on / power off. It enables to be “self-management” projector.

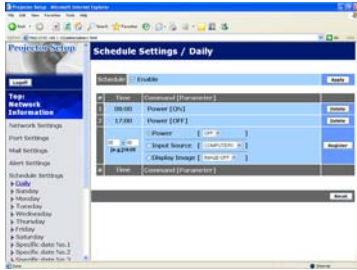

- NOTE** • You can schedule the following control events: Power ON/OFF, Input Source and Transferred Image Display.
- The power on / off event has the lowest priority among the all events that are defined at the same time.
  - There are 3 types of Scheduling, 1) daily 2) weekly 3) specific date. (75)
  - The priority for scheduled events is as follows 1) specific date 2) weekly 3) daily.
  - Up to five specific dates are available for scheduled events. Priority is given to those with the lower numbers when more than one event has been scheduled for the same date and time (e.g., ‘Specific day No. 1’ has priority over ‘Specific day No. 2’ and so on.
  - Be sure to set the date and time before enabling scheduled events. (77)

## 4.4 Event Scheduling (Continued)

### Schedule Settings (75)

Schedule settings can be configured from a web browser.

Example: If the IP address of the projector is set to 192.168.1.10:

- 1) Enter “**http://192.168.1.10/**” into the address bar of the web browser.
- 2) Enter the Administrator ID and password and click [**Logon**].
- 3) Click [**Schedule Settings**] on the main menu and select the required schedule item. For example, if you want to perform the command every Sunday, please select [**Sunday**].
- 4) Click [**Enable**] check box to enable scheduling.
- 5) Enter the date (month/day) for specific date scheduling.
- 6) Click [**Apply**] button to save the settings.
- 7) Click [**Add**] to create new event. After configure the time, command and parameters, click [**Register**] to add the new event. To return the previous page, click [**Cancel**] button.
- 8) Click [**Delete**] button when you want to delete a schedule.

There are three types of scheduling.

- 1) Daily: Perform the specified operation at a specified time every day.
- 2) Sunday ~ Saturday: Perform the specified operation at the specified time on a specified day of the week.
- 3) Specific Date: Perform the specified operation on the specified date and time.

**NOTE** • In Standby mode the power indicator will flash green for approx. 3 seconds when at least 1 “Power ON” schedule is saved.

- When the schedule function is used, the power cord must be connected to the projector and the outlet and the power switch must be turned on, [ | ]. The schedule function does not work when the power switch is turned off, [ O ] or the breaker in a room is tripped. The power indicator will lights orange or green when the projector gets is receiving the power.

### 4.4 Event Scheduling (Continued)

#### Date/Time Settings (📖77)

The Date/Time setting can be adjusted via a web browser.

Example: If the IP address of the projector is set to 192.168.1.10:

- 1) Enter “**http://192.168.1.10/**” into the address bar of the web browser. Enter the Administrator ID and Password and click [**Logon**].
- 2) Click [**Date/Time Settings**] on the main menu and configure each item. Refer to the item 4.1.8 Data/Time Settings for further information.
- 3) Click [**Apply**] button to save the settings.

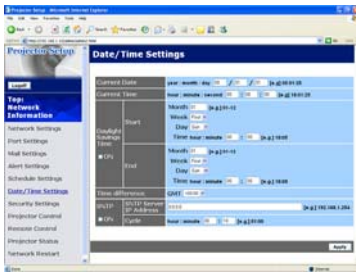

**NOTE** • The battery for the built in clock may be dead if the clock loses time even when the date and time have been set correctly. Replace the battery by following the instructions on replacing the battery.

(📖 **Internal clock battery in the User's Manual (concise)**)

- The internal clock's time may not remain accurate. Using SNTP is recommended to maintain accurate time.

## 4.5 e-SHOT (Still Image Transfer) Display

The projector can display a still image in an SD memory card or USB memory that is transferred via the network. (Fig. 4.5)

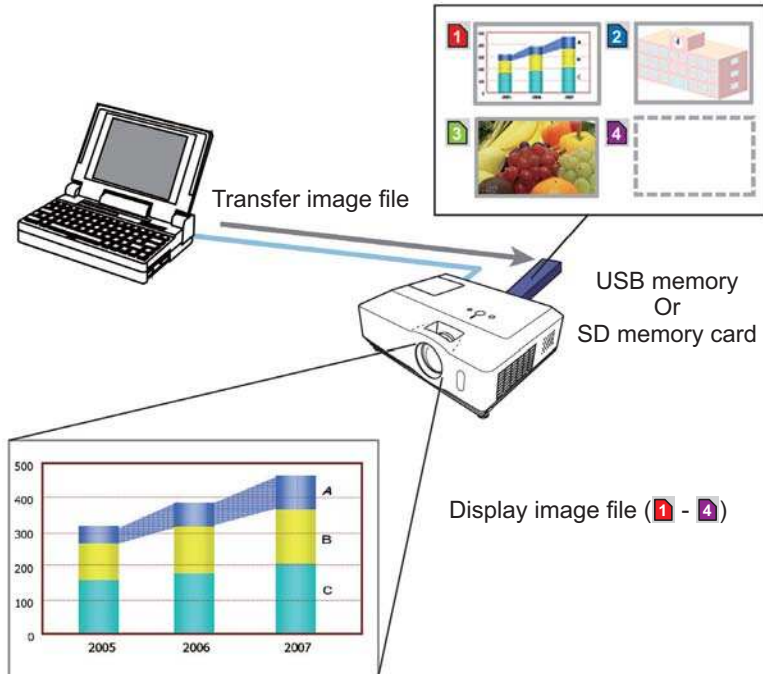

Fig. 4.5 Still Image Transfer

e-SHOT transmission requires an exclusive application for your PC. You can download it from the Hitachi web site (<http://hitachi.us/digitalmedia> or <http://www.hitachidigitalmedia.com>). Refer to the manual for the application for instructions.

To display the transferred image, select the e-SHOT item in the MIU Menu. For more information, please see the description of the e-SHOT item of the MIU Menu. (📖 *MIU Menu in User's Manual (detailed) – Operating Guide*)

**NOTE** • Supported file types are JPEG, Bitmap and PNG.  
 • It is possible to allocate the image file up to 4 in the maximum.  
 • The image file also can be displayed by using schedule function from the web browser. Refer to *the item 4.4 Event Scheduling* (📖92) in detail.

### 4.6 Command Control via the Network

You can configure and control the projector via the network using RS-232C commands.

#### Communication Port

The following two ports are assigned for the command control.

TCP #23

TCP #9715

#### Command Control Settings (71)

Configure the following items from a web browser when command control is used.  
Example: If the IP address of the projector is set to 192.168.1.10:

- 1) Enter “**http://192.168.1.10/**” into the address bar of the web browser.
- 2) Enter the Administrator ID and password and click [**Logon**].
- 3) Click [**Port Settings**] on the main menu.

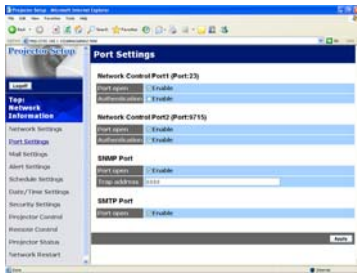

- 4) Click [**Enable**] check box to open **Network Control Port1 (Port: 23)** to use TCP #23. Click [**Enable**] check box for [**Authentication**] setting when authentication is required, otherwise clear the check box.
- 5) Click [**Enable**] check box to open **Network Control Port2 (Port: 9715)** to use TCP #9715. Click [**Enable**] check box for [**Authentication**] setting when authentication is required, otherwise clear the check box.
- 6) Click [**Apply**] button to save the settings.

#### 4.6 Command Control via the Network (Continued)

When the authentication setting is enabled, the following settings are required.

(79)

- 7) Click [**Security Settings**] on the main menu.
- 8) Click [**Network Control**] and enter the desired authentication password.
  - \* See NOTE.
- 9) Click [**Apply**] button to save the settings.

**NOTE** • The Authentication Password will be the same for Network Control Port1 (Port: 23), Network Control Port2 (Port: 9715).

## 4.6 Command Control via the Network (Continued)

### Command Format

Command formats differ among the different communication ports.

- TCP #23

You can use the RS-232C commands without any changes. The reply data format is the same as the RS-232C commands. However, the following reply will be sent back in the event of authentication failure when authentication is enabled.

<Reply in the event of an authentication error>

Reply	Error code	
0x1F	0x04	0x00

- TCP #9715

#### Send Data format

The following formatting is added to the header (0x02), Data length (0x0D), Checksum (1byte) and Connection ID (1 byte) of the RS-232C commands.

Header	Data length	RS-232Ccommand	Checksum	Connection ID
0x02	0x0D	13 bytes	1 byte	1 byte

Header → 0x02, Fixed

Data length → RS-232C commands byte length (0x0D, Fixed)

RS-232C commands → RS-232C commands that start with 0xBE 0xEF (13 bytes)

Check Sum → This is the value to make zero on the addition of the lower 8 bits from the header to the checksum.

Connection ID → Random value from 0 to 255 (This value is attached to the reply data)



## 4.6 Command Control via the Network (Continued)

### Reply Data format

The connection ID (the data is same as the connection ID data on the sending data format) is attached to the RS-232C commands reply data.

<ACK reply>

Reply	Connection ID
0x06	1 byte

<NAK reply>

Reply	Connection ID
0x15	1 byte

<Error reply>

Reply	Error code	Connection ID
0x1C	2 bytes	1 byte

<Data reply>

Reply	Data	Connection ID
0x1D	2 bytes	1 byte

<Projector busy reply>

Reply	Status code	Connection ID
0x1F	2 bytes	1 byte

<Authentication error reply>

Reply	Authentication Error code		Connection ID
0x1F	0x04	0x00	1 byte

### 4.6 Command Control via the Network (Continued)

#### Automatic Connection Break

The TCP connection will be automatically disconnected after there is no communication for 30 seconds after being established.

#### Authentication

The projector does not accept commands without authentication success when authentication is enabled. The projector uses a challenge response type authentication with an MD5 (Message Digest 5) algorithm.

When the projector is using a LAN, a random 8 bytes will be returned if authentication is enabled. Bind this received 8 bytes and the Authentication Password and digest this data with the MD5 algorithm and add this in front of the commands to send.

Following is a sample if the Authentication Password is set to “password” and the random 8 bytes are “a572f60c”.

- 1) Select the projector.
- 2) Receive the random 8 bytes “a572f60c” from the projector.
- 3) Bind the random 8 bytes “a572f60c” and the Authentication Password “password” and it becomes “a572f60cpassword”.
- 4) Digest this bind “a572f60cpassword” with MD5 algorithm.  
It will be “e3d97429adffa11bce1f7275813d4bde”.
- 5) Add this “e3d97429adffa11bce1f7275813d4bde” in front of the commands and send the data.  
Send “e3d97429adffa11bce1f7275813d4bde”+command.
- 6) When the sending data is correct, the command will be performed and the reply data will be returned. Otherwise, an authentication error will be returned.

**NOTE** • As for the transmission of the second or subsequent commands, the authentication data can be omitted when the same connection.

## 5. PC-LESS Presentation

### 5.1 Outline of the PC-LESS Presentation

The PC-LESS Presentation reads image data from storage media inserted into SD CARD slot or USB STORAGE port and displays the image on the following modes. The PC-LESS Presentation can be operated on the OSD menu in the projector screen or via a web browser software in your PC connected to the projector through the network.

The feature allows you to make your presentation without your PC.

- Thumbnail Mode (📖 103)
- Full Screen Mode (📖 107)
- Slide Show Mode (📖 109)
- Directory Tree View (📖 111)

**Thumbnail Mode**

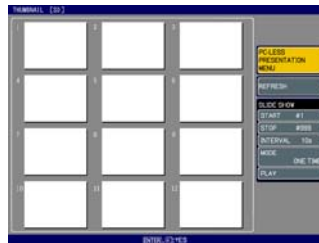
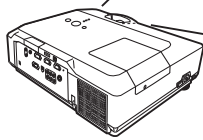

**Full Screen Mode**

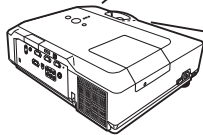

**Slide Show Mode**

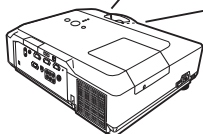

### 5.1 Outline of the PC-LESS Presentation (continued)

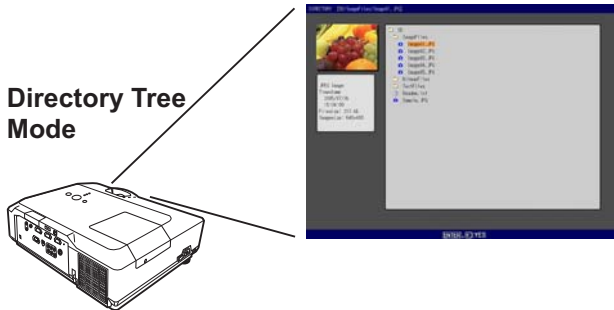

#### [Supported storage media]

- SD memory card
- USB memory (USB memory type, USB hard disk and USB card reader type)

**NOTE** • USB memory reader (adapter) that has more than 1 USB slot is not supported (if the adapter is acknowledged as multiple devices connected).

- USB hub is not supported.
- Security USB memory is not supported.
- Some SD memory cards and USB memories may not work correctly.
- SDHC (4GB etc) SD memory card is not supported. Up to 2GB card is supported.
- SD memory and the wireless network card cannot be inserted at the same time.
- Be careful to insert and remove SD memory card and USB memory.

(📖 *Using a USB storage/Using an SD card in the User's Manual (concise)*)

#### [Supported format]

- FAT12, FAT16 and FAT32

**NOTE** • NTFS is not supported

#### [Supported file format]

- JPEG (.jpeg, .jpg) \* Progressive is not supported.
- Bitmap (.bmp) \* 16bit mode and compressed bitmap is not supported.
- PNG (.png) \* Interlace PNG is not supported.
- MPEG4 (.mp4) \* Supported bit resolution rate is less than 1Mbps in Simple Profile.  
Supported resolution is less than VGA.  
Supported Audio format is only AAC.

## 5.2 Thumbnail mode

The Thumbnail mode displays the images stored in an SD or USB storage media in thumbnail screen. Maximum 12 images are displayed in a screen.

If you wish, you can jump into the Full Screen Mode or Slide Show mode, after you select some images in the Thumbnail mode.

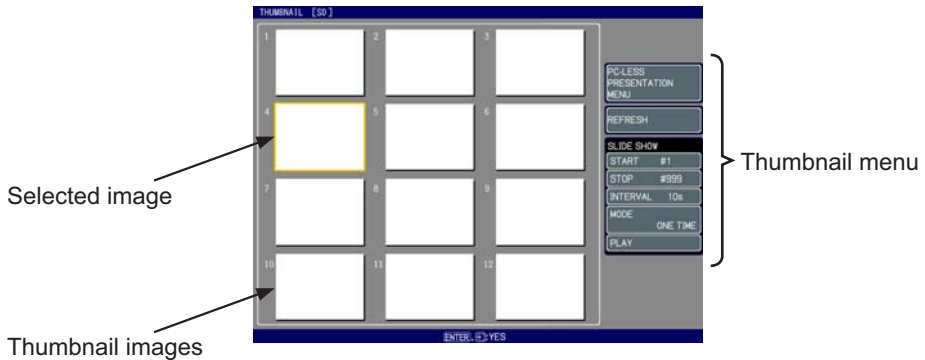

Fig. 5.2 Thumbnail Mode

### 5.2.1 Starting the Thumbnail mode

The Thumbnail mode can be started from the OSD menu in the projector or from a web browser software on your PC.

#### from the OSD menu

- 1) Save JPEG or other supported files (📖102) into root directory in a SD or USB storage media.
- 2) Insert the SD memory card into the SD card slot on the projector or the USB memory into the USB STORAGE port on the projector. (📖 **Using a USB storage/Using an SD card in the User's Manual (concise)**)
- 3) Press the MENU button on the remote control or the ▲/▼/◀/▶ buttons on the projector to show the menu on screen.
- 4) Use the ▲/▼ cursor buttons to select the Advanced Menu, and use the ▶ cursor button to enter the item.
- 5) Use the ▲/▼ cursor buttons to select the MIU, and use the ▶ cursor button to enter the item.

5.2 Thumbnail mode (continued)

- 6) Use the ▲/▼ cursor buttons to select the PC-LESS PRESENTATION, and push the ► cursor button.

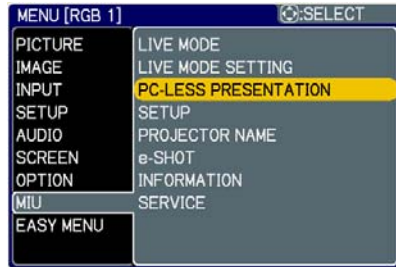

- 7) Use the ▲/▼ cursor buttons to select the THUMBNAIL, and push the ► cursor button to perform it. The picture in Fig. 5.2 will be on screen.

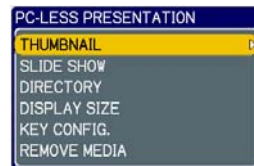

from a web browser software

- 1) Save JPEG or other supported files (📖102) into root directory in a SD or USB storage media.
- 2) Insert the SD memory card into the SD card slot on the projector or the USB memory into the USB STORAGE port on the projector. (📖 **Using a USB storage/Using an SD card in the User's Manual (concise)**)
- 3) Connect the projector and your PC through the network. (📖11 or 📖16 or 📖26)
- 4) Start a web browser software and logon to the projector. (📖67)
- 5) Select the Remote Control in the main menu to have the Remote Control screen on your PC.

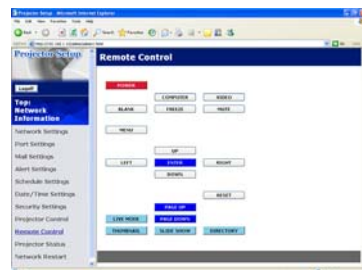

- 6) Select the THUMBNAIL and click it. The picture in Fig. 5.2 will be on screen.

## 5.2 Thumbnail mode (continued)

### 5.2.2 Operating by buttons or keys

You can control the images in the thumbnail screen with the remote control or keypad or a web browser software. The following functions can be supported while the thumbnail is displayed.

Button operation			Functions
The remote control	The keypad on the projector	Web Remote in web browser software.	
▲/▼/◀/▶	▲/▼/◀/▶	UP/DOWN/LEFT/RIGHT	Move cursor
PAGE UP PAGE DOWN	-	PAGE UP PAGE DOWN	Switches pages
ENTER	INPUT	ENTER	Displays selected image on full screen
MENU	-	MENU	Displays PC-LESS PRESENTATION menu

\* These operations are not accessible while the projector OSD menu is displayed.

- NOTE** • The Thumbnail mode shows 12 pictures in 1 page as maximum.
- It is not possible to change the input port by INPUT button when THUMBNAIL, SLIDE SHOW, or DIRECTORY is displayed.
  - Display the projector OSD menu before changing the input port.
  - Some error Icons will be displayed in thumbnail.



This file seems to be broken or not supported format.



The file name exists in the playlist file (📖115), but the actual file does not exist anywhere.

### 5.2 Thumbnail mode (continued)

#### 5.2.3 Operation on the Thumbnail menu

At the right side of the Thumbnail screen, you can find the Thumbnail menu.

1) PC-LESS PRESENTATION MENU:

Move the cursor to the PC-LESS PRESENTATION MENU, and push the ► cursor button on the remote control or projector, or RIGHT on the Web Remote Control. The PC-LESS PRESENTATION menu will be displayed.

2) REFRESH:

Move the cursor to the REFRESH, and push the ► cursor button on the remote control or projector, or RIGHT on the Web Remote Control. Then, the warning message for the REFRESH will be displayed. The Refresh is a function to initialize the playlist. (📖115)  
If you initialize it, the thumbnail screen is renewed and the images are back to the original condition.



To initialize it, push the ENTER on the remote control or Web Remote Control, or INPUT on the projector.  
To escape to the Thumbnail menu, push the ESC on the remote control or the ◀ key on the projector or the LEFT button on the Web Remote Control.

**NOTE** • If you initialize it, the setting for the Slide show and the rotation setting for images will be initialized as well.

- If the storage media is protected, the playlist cannot be initialized.
- If the storage media does not have the space to store the new playlist file, the playlist cannot be initialized.
- For other functions in the menu, refer to the Slide Show. (📖109)



### 5.3 Full Screen Mode

The Full Screen Mode (Fig. 5.3) shows a full display image. To make full screen display, press the ENTER button on remote control or the INPUT button on Keypad or click [ENTER] button in the Web Remote Control when the image file is selected on the Thumbnail Mode or Directory Tree View.



Fig. 5.3 Full Screen Mode

The following functions can be supported in the Full screen mode.

Button operation *1)			Functions
The remote control	The keypad on the projector	Web Remote in web browser software.	
▲/▼ or ◀/▶ *2)	▲/▼ or ◀/▶ *2)	UP/DOWN or LEFT/RIGHT *2)	<ul style="list-style-type: none"> <li>Rotates image 90 degrees clockwise or anticlockwise. Once image is rotated, the angle information is kept in the playlist even though the mode is switched to other. (Thumbnail or Slide Show Mode) To return the original, rotate the image back to the initial angle or erase the playlist file in memory card. (115)</li> <li>Moves the slide forward or backward</li> </ul>
ENTER	INPUT	ENTER	(from Thumbnail Mode) Displays thumbnail.
MENU	-	MENU	Displays PC-LESS PRESENTATION menu.

\*1) These operations are not accessible while the projector OSD menu is displayed.

\*2) The function for the pair of keys is selected on the KEY CONFIG. menu (108)

**NOTE** • It is not possible to change the input port by INPUT button of keypad when displaying the THUMBNAIL, SLIDE SHOW, or DIRECTORY.

- Display the projector OSD menu before changing the input port.
- Image might not be displayed properly at the beginning or end of MP4 file playback.

### 5.3 Full Screen Mode (continued)

You can display the image file with your desired size.

- 1) Select the DISPLAY SIZE in PC-LESS PRESENTATION menu.
- 2) Press the ENTER button on the remote control or ► button on the Keypad or RIGHT button on the Web Remote Control.



- 3) Then DISPLAY SIZE menu appears.



- 4) Select your desired DISPLAY SIZE.
  - REAL : Displays the image at original size. Displays the image at the center of screen if original size is smaller than the screen size. Displays only center of the image if original size is larger than the screen size.
  - NORMAL : Displays the image for the maximum size on the screen, and keeps original aspect.
  - FULL : Displays the image at the full size screen. Original aspect will be changed to full size display.

The animation file is always played at VGA mode if resolution is larger than VGA. The animation file is always played at the center of screen if resolution is smaller than VGA.

You can select the KEY configuration from 2 preset pattern assigned to ▲/▼/◀/▶ keys on Thumbnail Mode.

- 1) Select the KEY CONFIG. in PC-LESS PRESENTATION menu.
- 2) Press ► button.
- 3) The KEY CONFIG. menu appears.

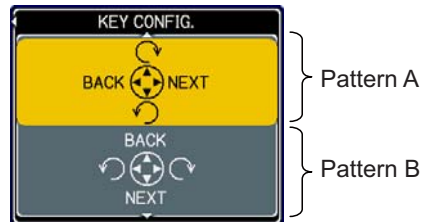

- 4) Select the KEY CONFIG. pattern.
  - pattern A : ◀ : previous image      ▶ : next image  
                  ▲ : rotation to right      ▼ : rotation to left
  - pattern B : ◀ : rotation to left      ▶ : rotation to right  
                  ▲ : previous image      ▼ : next image

## 5.4 Slide Show Mode

You can play the Slide show with the projector menu. Select the SLIDE SHOW on PC-LESS PRESENTATION menu and press the ENTER / ► button on the remote control or ► button on Keypad. Then Slide show will start.



You can also play the Slide show by clicking **[SLIDE SHOW]** button in the Web Remote Control.

The Slide Show Mode (Fig. 5.4) displays a full screen image and switches the images at intervals set in the Display time. The Display time can be set by the Playlist (📖115) and menu. (📖110)

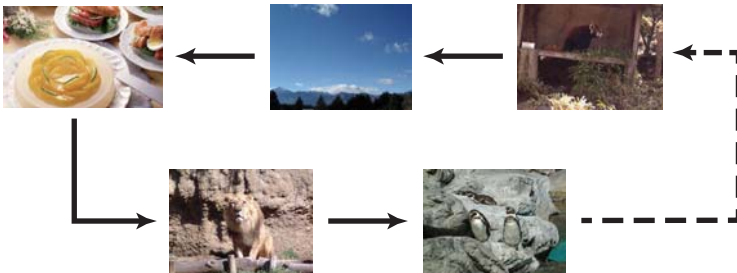

Fig. 5.4 Slide Show Mode

The following operations can be accessible while the Slide show is displayed.

Button operation			Functions
The remote control	The keypad on the projector	Web Remote in web browser software.	
ENTER	INPUT	ENTER	Displays thumbnail.
MENU	-	MENU	Displays PC-LESS PRESENTATION menu.

\* These operations are not accessible while the projector OSD menu is displayed.

- NOTE**
- It is impossible to change the input port by the INPUT button if the THUMBNAIL, SLIDE SHOW, or DIRECTORY is displayed.
  - Display the projector OSD menu before changing the input port .
  - Images can be displayed when it is recorded in the playlist.
  - Image can not be displayed in the thumbnail if it is not recorded in the playlist. (📖115)
  - When the SLIDE SHOW mode is set to ONE TIME, the last slide of the presentation will be held on screen till the ENTER button on the remote control or Web Remote Control, or INPUT button on the projector is pushed.

### 5.4 Slide Show Mode (continued)

You can play the Slide show at your desired configuration. Configure the SLIDE SHOW items in THUMBNAIL.

- 1) START # : Set the beginning number of the Slide show.
- 2) STOP # : Set the end number of the Slide show.
- 3) INTERVAL : Set the interval time of the Slide show.
- 4) MODE : Select the Slide show mode.  
ONE TIME : Play the Slide show one time.  
ENDLESS : Play the Slide show endless.
- 5) PLAY : Play the Slide show.  
It is not recommend to set the interval time very short something like several seconds, because it may take more than several seconds to read and display an image file if it is stored in very deep layer directory or if so many files are stored in the same directory.



**NOTE** • The settings of the Slide Show are saved to the “**slidemode.txt**” file that is stored in the storage media. If the file is not existed, it is generated automatically.

- The START #, STOP #, INTERVAL, and MODE are set by thumbnail menu once, this setting has more priority than the Playlist.
- If the storage media is under the write protection or the “**slidemode.txt**” is the read only type file, it is impossible to change the settings of the Slide Show.
- If you would like to release the priority, delete the “**slidemode.txt**” file from directory.

## 5.5 Directory Tree View

You can display the directory with the projector menu. Select the DIRECTORY on the PC-LESS PRESENTATION menu. And press the ENTER / ► button on the remote control or ► button on Keypad. Then directory will be displayed.



You can also display the directory by clicking **[DIRECTORY]** button in the Web Remote Control.

The Directory Tree View (Fig. 5.5) displays all folders and files (includes unsupported format file) in the memory card as a tree view. The preview image is shown on the top left corner on the directory tree view. In case of movie file, an initial frame is displayed as preview. No preview is displayed if a folder or un-supported format file is selected. If the displayable file is selected and the ENTER button on remote control is pressed, it turns into the full screen image. If the directory is selected and the ENTER button on remote control is pressed, it turns into the thumbnail view of selected folder.

You can also display the full screen image or the thumbnail view by clicking **[ENTER]** button in the Web Remote Control.



Fig. 5.5 Directory Tree View

**5.5 Directory Tree View (continued)**

The following operations can be accessible while directory is displayed.

Button operation			Functions
The remote control	The keypad on the projector	Web Remote in web browser software.	
▲/▼	▲/▼	UP/DOWN	Moves selected item upward or downward.
▶	▶	RIGHT	Opens the closed folder.
◀	◀	LEFT	Closes the folder.
PAGE UP PAGE DOWN	-	PAGE UP PAGE DOWN	Switches pages if the whole directory tree view cannot be displayed.
ENTER	INPUT	ENTER	Displays a selected file as a preview in full screen. The un-supported format file cannot be opened. If the preview is displayed and Enter button is pressed, it returns to the directory tree view. If the directory (folder) is selected, it turns into Thumbnail Mode.
MENU	-	MENU	Displays the menu.

\* These operations are not accessible while projector OSD menu is displayed.

**NOTE** • It is not possible to change the input port by INPUT button when THUMBNAIL, SLIDE SHOW, or DIRECTORY is displayed.

- Display the projector OSD menu before changing the input port .
- Only alphanumeric characters can be used for directory name and file name.
- This Directory Tree View is able to show up to 10 layers depth. The files and folders that located on more than 10th layer cannot be shown. Some files and directories are not displayed if there are too many. In this case, delete some files in the directory or some directories in the memory card.

## 5.5 Directory Tree View (continued)

### [File information display]

In the Directory Tree View screen, the following information is shown as the File information.

#### Picture file (still picture)

- File format (“JPEG Image”, “PNG Image” or “BMP Image”)
- Time stamp (When file is created)
- File size (Size of File)
- Image size (File resolution)

#### Movie file (motion picture)

- File format (“MP4 Movie”)
- Time stamp (When file is created)
- File size (Size of File)
- Movie size (File resolution)
- Movie time (Play time)

#### Un-supported format file

- File format (“File”)
- Time stamp (When file is created)
- File size (Size of File)

#### Directory

- File format (“Directory”)
- Time stamp (When directory is created)

## 5.6 “PC-LESS Presentation” error message

Error message is displayed at a specific condition while “PC-LESS Presentation” mode. It appears at the bottom and the gray area of screen.



Fig. 5.6 “PC-LESS Presentation” error message

### “PC-LESS Presentation” error message list

Error message	Error content	Display mode
File is not found.	Displayable file does not exist.	The Full Screen Mode (from Thumbnail Mode) and Side Show Mode
Illegal Playlist file.	The Playlist file has malfunction. (Over 64kB file, over 1022 characters per line in file or linefeed code malfunction)	The Slide Show Mode



## 5.7 Playlist

The Playlist is a DOS format text file, which decides the order of displayed still image files or moving image files in the thumbnail or the slide show.

The playlist file name is “**imagelistdir.txt**”. It is created in each folder when the PC-LESS Presentation is displayed. The timing of playlist creation is when PC-LESS Presentation is displayed in the directory, which any playlist file does not exist. The playlist is created in the displayed directory.

The playlist is editable on the PC. Display time and rotation information at the slide show can be set based on specifying settings. Of course it is possible to make certain file image undisplayable in a playlist deleting 1 line relating to the file from playlist. Also, it is possible to see added picture image based on adding picture image file name and pass name of destination to save in playlist.

### [Example of adding image file]

(Pass name/pass name/.../file name, display time, rotation information)

images/photo1/img001.jpg

images/photo1/img002.jpg, 2000

images/photo1/img003.jpg, 500, rot1

images/photo1/img004.jpg

images/photo1/img005.jpg, 500, rot2

The number after the extension is the slide show display time. It can be set between 0 and 999900. (ms) Least input increment is 100 ms. The end of display time means rotation information. 90 degrees clockwise rotation becomes rot1, rot2 and rot3. (When no rotation, not specify or specify rot0.)

Display time and rotation information should be used “,” for separation.

- ⚠ CAUTION** • Maximum characters for the playlist in 1 line at playlist is 1024 including linefeed. If it exceeds, playlist becomes invalid and error.
- Playlist maximum size is 64kB. If it exceeds, it becomes invalid.
  - Playlist can register up to 999 image files. If it exceeds, first 999 files can be utilized.
  - When image file is added to the memory card and be able to see on the screen, delete existing playlist in the memory card.

6. Troubleshooting

Problem		Likely Cause	Things to Check	Reference Page Number	
No image		The projector is not turned on.	Is the projector's lamp on?	*16	
		The projector's input source isn't switched to MIU.	Is the projector switched to MIU?	*17	
Wireless / Wired	Live Mode	The projector that you want to connect to is nowhere to be found on the list of available projectors	The PC and/or projector's network settings are not configured correctly.	Check both the PC and projector's network settings. If you change the projector's settings, turn off the projector's AC power and then turn it on again. If you simply put the projector in STANDBY power mode and then turn it on again, the new settings might not take effect.	10
		Weak radio signal	<ul style="list-style-type: none"> <li>Bring the PC and projector closer together</li> <li>Radio waves won't go through concrete and metal (steel doors, etc.)</li> </ul>	–	
	Can't communicate	The Projector isn't in Live Mode	Check the mode on MIU Menu to make sure that it is in the correct mode.	53	
	The projected image is rather slow compared to that of the PC	The projector isn't capable of relaying dynamic images such as PowerPoint® animation at full speed.	Try increasing the Capture Performance priority level. It may improve the speed a little.	58	
		"Optimize Performance" is set to "Image quality".	Try setting "Optimize Performance" to "Transmission speed".	58	

(continued on next page)

\* User's Manual (detailed) - Operating Guide

## 6. Troubleshooting (Continued)

Problem		Likely Cause	Things to Check	Reference Page Number	
Wireless / Wired	Live Mode	Lots of interference in the images	“Optimize Performance” is set to “Transmission speed”.	“Optimize Performance” to “Image quality”.	58
		Two cursors appear	Cursor of the PC and cursor of the projector are displayed coming in succession.	Turn off the cursor Emulation of “Live Viewer 3” option.	58
		No cursor appears	Some PCs do not display the cursor in “Live Viewer 3”.	Turn on the cursor Emulation of “Live Viewer 3” option.	58
PC-LESS	No information is shown after mass storage device is set on Thumbnail or Directory mode.	The mode setting is not renewed after the device is set.	Select either Thumbnail mode or Directory mode again, showing PC-LESS Presentation menu.	103, 111	
Wireless	Can't communicate	The wireless network card isn't inserted into the projector or the memory card is still inserted.	Insert the wireless network card that came with your projector into the module.	*12	
		There is closely another projector or other that has the same wireless setting.	Try changing of SSID and IP Address.	*50 *57	
Wired LAN	Can't communicate	The PC and/or projector's network settings are not configured correctly.	Check both the PC and projector's network settings.	11-13, 41	
		The wireless network card is inserted into the projector.	Remove the SD wireless network card from the projector (you can't use both wireless and wired LAN connections at the same time).	*56	
Others - Information from the projector to PC is not correct or completed - The projector does not respond - Image on screen is frozen.		Communication between the projector and PC is not working well.  MIU Functions of the projector is not working well.	Try “MIU RESTART” in SERVICE menu under the MIU menu.	*62	

\* User's Manual (detailed) - Operating Guide

## 7. Specifications

### 7. Specifications

Item	Specifications
<b>File format</b>	JPEG, PNG, Bitmap and MPEG4
<b>Control software</b>	Dedicated PC application and Web browser
<b>Corresponding protocol</b>	TCP/IP, DHCP client and HTTP server
<b>Network</b>	Wireless LAN (IEEE802.11b/g) (Ad-Hoc and Infrastructure modes) Ethernet (100Base-TX/10Base-T)
<b>Security</b>	WEP (64/128bit), WPA-PSK/PSK2 (TKIP/AES), SSID
<b>PC application operational environment</b>	OS: Windows® XP Home Edition/ Professional Windows® 2000 Professional Service Pack 4 CPU: Pentium III 600MHz or more is recommended. Memory size: 64MB or more, 128MB or more in case of XP Video RAM: 4MB required (8MB recommended) HDD: 10MB CD-ROM drive Web browser: Internet Explorer 5.5 or later
<b>SD Memory Card</b>	SD Memory Card (Corresponding card is not confirmed yet.)
<b>Wireless network card</b>	C-guys SD-Link11g
<b>USB</b>	USB1.0 host mass storage class SBC/BOT type Following USB memories can be read/written. - USB memory type - Card reader type (Corresponding card is not confirmed yet.)

### 8. Warranty and after-sales service

If a problem occurs with the equipment, please read “6. Troubleshooting” ( 116) section first and review all suggested check points. After that, please contact your dealer or service company, if you still have the problem. They will tell you what warranty condition is applied.

## Projector

# CP-X308

## User's Manual (detailed)

### Technical

#### Example of PC signal

Resolution (H x V)	H. frequency (kHz)	V. frequency (Hz)	Rating	Signal mode
720 x 400	37.9	85.0	VESA	TEXT
640 x 480	31.5	59.9	VESA	VGA (60Hz)
640 x 480	37.9	72.8	VESA	VGA (72Hz)
640 x 480	37.5	75.0	VESA	VGA (75Hz)
640 x 480	43.3	85.0	VESA	VGA (85Hz)
800 x 600	35.2	56.3	VESA	SVGA (56Hz)
800 x 600	37.9	60.3	VESA	SVGA (60Hz)
800 x 600	48.1	72.2	VESA	SVGA (72Hz)
800 x 600	46.9	75.0	VESA	SVGA (75Hz)
800 x 600	53.7	85.1	VESA	SVGA (85Hz)
832 x 624	49.7	74.5		Mac 16" mode
1024 x 768	48.4	60.0	VESA	XGA (60Hz)
1024 x 768	56.5	70.1	VESA	XGA (70Hz)
1024 x 768	60.0	75.0	VESA	XGA (75Hz)
1024 x 768	68.7	85.0	VESA	XGA (85Hz)
1152 x 864	67.5	75.0	VESA	1152 x 864 (75Hz)
1280 x 960	60.0	60.0	VESA	1280 x 960 (60Hz)
1280 x 1024	64.0	60.0	VESA	SXGA (60Hz)
1280 x 1024	80.0	75.0	VESA	SXGA (75Hz)
1280 x 1024	91.1	85.0	VESA	SXGA (85Hz)
1600 x 1200	75.0	60.0	VESA	UXGA (60Hz)
1280 x 768	47.7	60.0	VESA	W-XGA (60Hz)
1400 x 1050	65.2	60.0	VESA	SXGA+ (60Hz)

- NOTE**
- Be sure to check jack type, signal level, timing and resolution before connecting this projector to a PC.
  - Some PCs may have multiple display screen modes. Use of some of these modes will not be possible with this projector.
  - Depending on the input signal, full-size display may not be possible in some cases. Refer to the number of display pixels above.
  - Although the projector can display signals with resolution up to UXGA (1600x1200), the signal will be converted to the projector's panel resolution before being displayed. The best display performance will be achieved if the resolutions of the input signal and projector panel are identical.
  - Automatic adjustment may not function correctly with some input signals.
  - The image may not be displayed correctly when the input sync signal is a composite sync or a sync on G.

## Initial set signals

### Initial set signals

The following signals are used for the initial settings. The signal timing of some PC models may be different. In such case, adjust the items V POSITION and H POSITION in IMAGE menu.

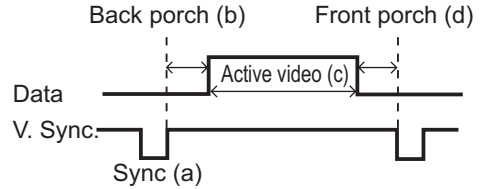
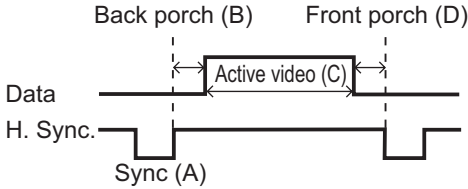

computer Signal	Horizontal signal timing ( $\mu$ s)			
	(A)	(B)	(C)	(D)
TEXT	2.0	3.0	20.3	1.0
VGA (60Hz)	3.8	1.9	25.4	0.6
VGA (72Hz)	1.3	4.1	20.3	0.8
VGA (75Hz)	2.0	3.8	20.3	0.5
VGA (85Hz)	1.6	2.2	17.8	1.6
SVGA (56Hz)	2.0	3.6	22.2	0.7
SVGA (60Hz)	3.2	2.2	20.0	1.0
SVGA (72Hz)	2.4	1.3	16.0	1.1
SVGA (75Hz)	1.6	3.2	16.2	0.3
SVGA (85Hz)	1.1	2.7	14.2	0.6
Mac 16" mode	1.1	3.9	14.5	0.6
XGA (60Hz)	2.1	2.5	15.8	0.4
XGA (70Hz)	1.8	1.9	13.7	0.3
XGA (75Hz)	1.2	2.2	13.0	0.2
XGA (85Hz)	1.0	2.2	10.8	0.5
1152 x 864 (75Hz)	1.2	2.4	10.7	0.6
1280 x 960 (60Hz)	1.0	2.9	11.9	0.9
SXGA (60Hz)	1.0	2.3	11.9	0.4
SXGA (75Hz)	1.1	1.8	9.5	0.1
SXGA (85Hz)	1.0	1.4	8.1	0.4
UXGA (60Hz)	1.2	1.9	9.9	0.4
W-XGA (60Hz)	1.7	2.5	16.0	0.8
SXGA+ (60Hz)	1.2	2.0	11.4	0.7

computer Signal	Vertical signal timing (lines)			
	(a)	(b)	(c)	(d)
TEXT	3	42	400	1
VGA (60Hz)	2	33	480	10
VGA (72Hz)	3	28	480	9
VGA (75Hz)	3	16	480	1
VGA (85Hz)	3	25	480	1
SVGA (56Hz)	2	22	600	1
SVGA (60Hz)	4	23	600	1
SVGA (72Hz)	6	23	600	37
SVGA (75Hz)	3	21	600	1
SVGA (85Hz)	3	27	600	1
Mac 16" mode	3	39	624	1
XGA (60Hz)	6	29	768	3
XGA (70Hz)	6	29	768	3
XGA (75Hz)	3	28	768	1
XGA (85Hz)	3	36	768	1
1152 x 864 (75Hz)	3	32	864	1
1280 x 960 (60Hz)	3	36	960	1
SXGA(60Hz)	3	38	1024	1
SXGA (75Hz)	3	38	1024	1
SXGA (85Hz)	3	44	1024	1
UXGA (60Hz)	3	46	1200	1
W-XGA (60Hz)	3	23	768	1
SXGA+ (60Hz)	3	33	1050	1

Connection to the ports

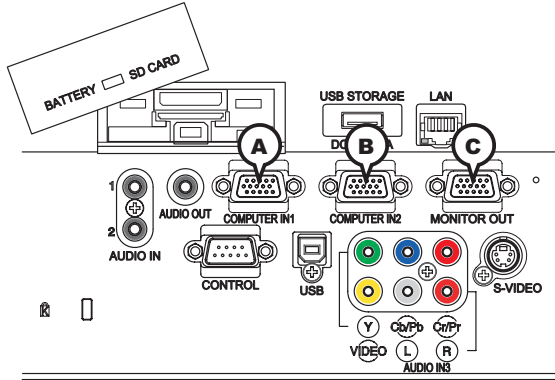

**ⒶCOMPUTER IN1, ⒷCOMPUTER IN2, ⒸMONITOR OUT**

D-sub 15pin mini shrink jack

- Video signal: RGB separate, Analog, 0.7Vp-p, 75Ω terminated (positive)
- H/V. sync. signal: TTL level (positive/negative)
- Composite sync. signal: TTL level

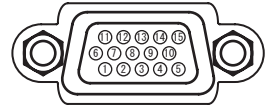

Pin	Signal	Pin	Signal
1	Video Red	10	Ground
2	Video Green	11	(No connection)
3	Video Blue	12	Ⓐ: SDA (DDC data) Ⓑ, Ⓒ: (No connection)
4	(No connection)		
5	Ground	13	H. sync / Composite sync.
6	Ground Red	14	V. sync.
7	Ground Green	15	Ⓐ: SCL (DDC clock) Ⓑ, Ⓒ: (No connection)
8	Ground Blue		
9	(No connection)	-	-



## Connection to the ports (continued)

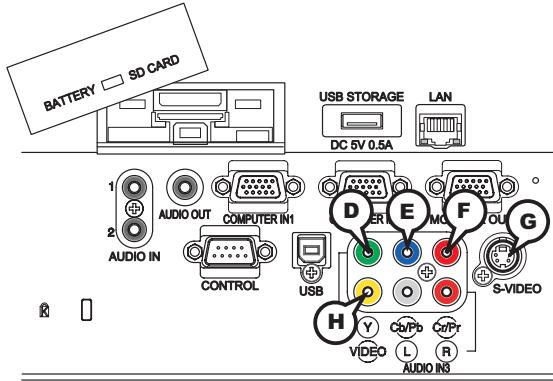

### COMPONENT VIDEO (D) Y, (E) Cb/Pb, (F) Cr/Pr

RCA jack x3

- System: 525i(480i), 525p(480p), 625i(576i), 750p(720p), 1125i(1080i)

Port	Signal
Y	Component video Y, $1.0 \pm 0.1V_{p-p}$ , $75\Omega$ terminator with composite sync
Cb/Pb	Component video Cb/Pb, $0.7 \pm 0.1V_{p-p}$ , $75\Omega$ terminator
Cr/Pr	Component video Cr/Pr, $0.7 \pm 0.1V_{p-p}$ , $75\Omega$ terminator

### (G) S-VIDEO

Mini DIN 4pin jack



Pin	Signal
1	Color signal $0.286V_{p-p}$ (NTSC, burst), $75\Omega$ terminator Color signal $0.300V_{p-p}$ (PAL/SECAM, burst) $75\Omega$ terminator
2	Brightness signal, $1.0V_{p-p}$ , $75\Omega$ terminator
3	Ground
4	Ground

### (H) VIDEO

RCA jack

- System: NTSC, PAL, SECAM, PAL-M, PAL-N, NTSC4.43
- $1.0 \pm 0.1V_{p-p}$ ,  $75\Omega$  terminator

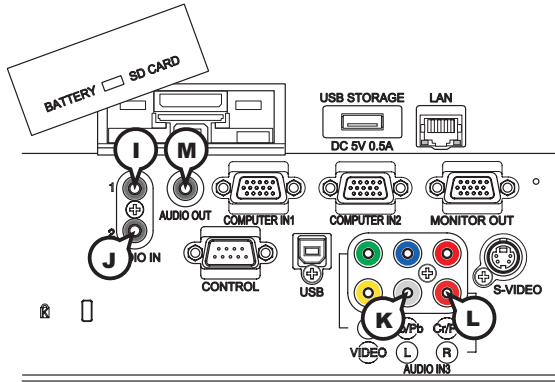

**ⓐAUDIO IN1, ⓐAUDIO IN2**

Ø3.5 stereo mini jack

- 200 mVrms 47kΩ terminator

**AUDIO IN3 ⓐL, ⓐR**

RCA jack x2

- 200 mVrms 47kΩ terminator

**ⓐAUDIO OUT**

Ø3.5 stereo mini jack

- 200 mVrms 1kΩ output impedance

**To input SCART RGB signal;**

ex.:

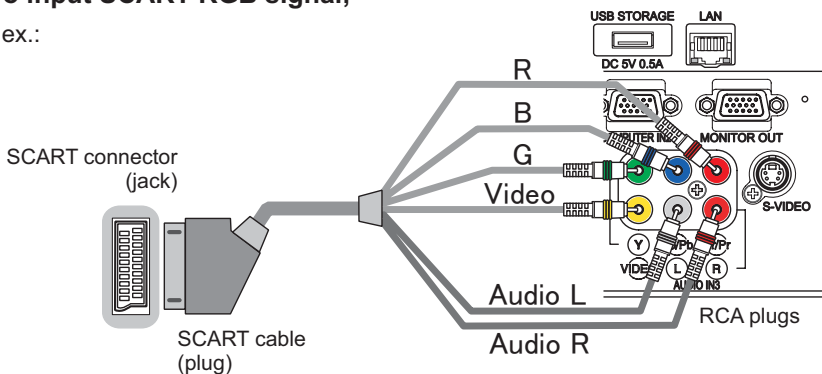

To input SCART RGB signal to the projector, use a SCART to RCA cable. Connect the plugs refer to above ex.. For more reference, please consult your dealer.

## Connection to the ports (continued)

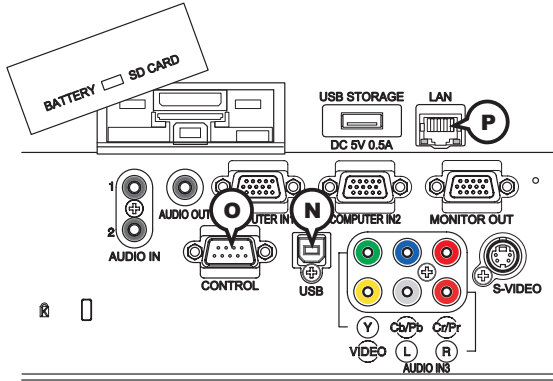

### **(N)** USB

USB B type jack

Pin	Signal
1	+5V
2	- Data
3	+ Data
4	Ground



### **(O)** CONTROL

D-sub 9pin plug

• About the details of RS-232C communication, please refer to the following page.

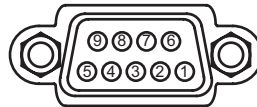

Pin	Signal	Pin	Signal	Pin	Signal
1	(No connection)	4	(No connection)	7	RTS
2	RD	5	Ground	8	CTS
3	TD	6	(No connection)	9	(No connection)

### **(P)** LAN

RJ-45 jack

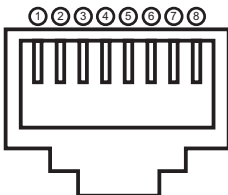

Pin	Signal	Pin	Signal	Pin	Signal
1	TX +	4	-	7	-
2	TX -	5	-	8	-
3	RX +	6	RX -	-	-

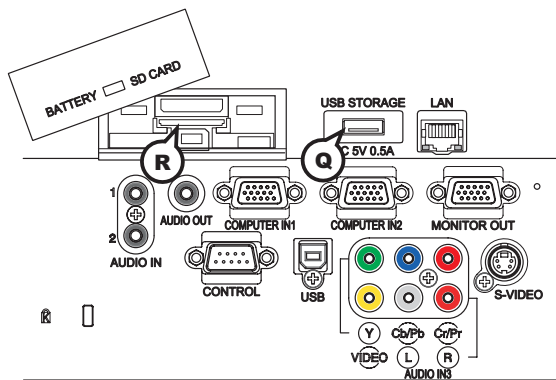

### Q USB STORAGE

USB A type jack

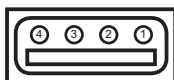

Pin	Signal
1	+5V
2	- Data
3	+ Data
4	Ground

### R SD card slot

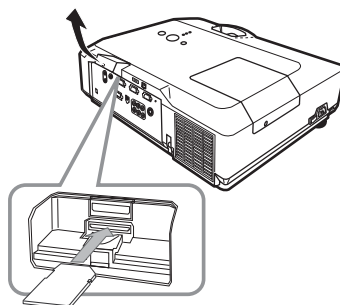

SD card slot



Pin	Signal	Pin	Signal	Pin	Signal
1	CD/DAT 3	4	VDD	7	DAT 0
2	CMD	5	CLK	8	DAT 1
3	VSS	6	VSS	9	DAT 2

## RS-232C Network Communication

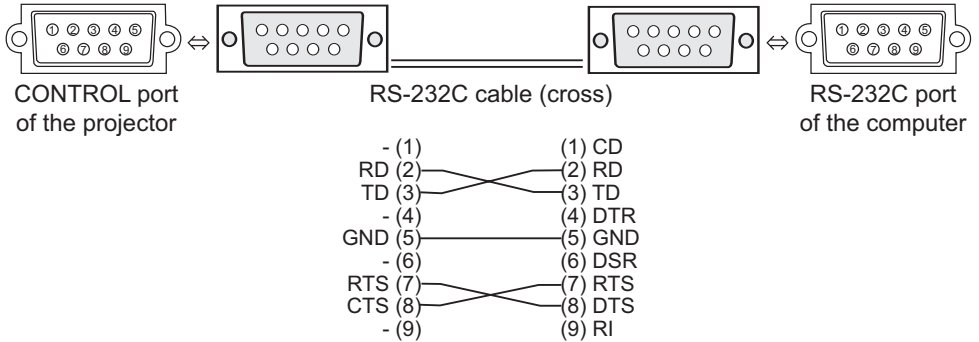

### Connecting the cable

1. Turn off the projector and the computer.
2. Connect the CONTROL port of the projector with a RS-232C port of the computer by a RS-232C cable (cross). Use the cable that fulfills the specification shown in the previous page.
3. Turn the computer on, and after the computer has started up turn the projector on.

### Communications setting

19200bps, 8N1

#### 1. Protocol

Consist of header (7 bytes) + command data (6 bytes)

#### 2. Header

BE + EF + 03 + 06 + 00 + CRC\_low + CRC\_high

CRC\_low: Lower byte of CRC flag for command data

CRC\_high: Upper byte of CRC flag for command data

#### 3. Command data

Command data chart

byte_0	byte_1	byte_2	byte_3	byte_4	byte_5
Action		Type		Setting code	
low	high	low	high	low	high

Action (byte\_0 - 1)

Action	Classification	Content
1	Set	Change setting to desired value.
2	Get	Read projector internal setup value.
4	Increment	Increment setup value by 1.
5	Decrement	Decrement setup value by 1.
6	Execute	Run a command.

**Requesting projector status (Get command)**

- (1) Send the following request code from the PC to the projector.  
*Header + Command data ('02H' + '00H' + type (2 bytes) + '00H' + '00H')*
- (2) The projector returns the response code '1DH' + data (2 bytes) to the PC.

**Changing the projector settings (Set command)**

- (1) Send the following setting code from the PC to the projector.  
*Header + Command data ('01H' + '00H' + type (2 bytes) + setting code (2 bytes))*
- (2) The projector changes the setting based on the above setting code.
- (3) The projector returns the response code '06H' to the PC.

**Using the projector default settings (Reset Command)**

- (1) The PC sends the following default setting code to the projector.  
*Header + Command data ('06H' + '00H' + type (2 bytes) + '00H' + '00H')*
- (2) The projector changes the specified setting to the default value.
- (3) The projector returns the response code '06H' to the PC.

**Increasing the projector setting value (Increment command)**

- (1) The PC sends the following increment code to the projector.  
*Header + Command data ('04H' + '00H' + type (2 bytes) + '00H' + '00H')*
- (2) The projector increases the setting value on the above setting code.
- (3) The projector returns the response code '06H' to the PC.

**Decreasing the projector setting value (Decrement command)**

- (1) The PC sends the following decrement code to the projector.  
*Header + Command data ('05H' + '00H' + type (2 bytes) + '00H' + '00H')*
- (2) The projector decreases the setting value on the above setting code.
- (3) The projector returns the response code '06H' to the PC.

**When the projector cannot understand the received command**

When the projector cannot understand the received command, the error code '15H' is sent back to the PC.

Sometimes the projector cannot properly receive the command. In such a case, the command is not executed and the error code '15H' is sent back to the PC. If this error code is returned, send the same command again.

**When the projector cannot execute the received command.**

When the projector cannot execute the received command, the error code '1CH' + 'xxxH' is sent back to the PC.

When the data length is greater than indicated by the data length code, the projector ignore the excess data code. Conversely when the data length is shorter than indicated by the data length code, an error code will be returned to the PC.

**NOTE** • Operation cannot be guaranteed when the projector receives an undefined command or data.

- Provide an interval of at least 40ms between the response code and any other code.
- The projector outputs test data when the power supply is switched ON, and when the lamp is lit. Ignore this data.
- Commands are not accepted during warm-up.

## Command Control via the Network

### Communication Port

The following two ports are assigned for the command control.

TCP #23

TCP #9715

### Command Control Settings

Configure the following items from a web browser when command control is used.

Port Settings		
<b>Network Control Port1 (Port: 23)</b>	Port open	Click the <b>[Enable]</b> check box to open <b>[Network Control Port1 (Port: 23)]</b> to use TCP #23. Default setting is "Enable".
	Authentication	Click the <b>[Enable]</b> check box for the <b>[Authentication]</b> setting when authentication is required. Default setting is "Disable".
<b>Network Control Port2 (Port: 9715)</b>	Port open	Click the <b>[Enable]</b> check box to open <b>[Network Control Port2 (Port: 9715)]</b> to use TCP #9715. Default setting is "Enable".
	Authentication	Click the <b>[Enable]</b> check box for the <b>[Authentication]</b> setting when authentication is required. Default setting is "Enable".

When the authentication setting is enabled, the following settings are required.

Security Settings		
<b>Network Control</b>	Authentication Password	Enter the desired authentication password. This setting will be the same for <b>[Network Control Port1 (Port: 23)]</b> and <b>[Network Control Port2 (Port: 9715)]</b> . Default setting is blank.
	Re-enter Authentication Password	

## Command Format

### [TCP #23]

#### 1. Protocol

Consist of header (7 bytes) + command data (6 bytes)

#### 2. Header

BE + EF + 03 + 06 + 00 + CRC\_low + CRC\_high

CRC\_low: Lower byte of CRC flag for command data

CRC\_high: Upper byte of CRC flag for command data

#### 3. Command data

Command data chart

byte_0	byte_1	byte_2	byte_3	byte_4	byte_5
Action		Type		Setting code	
low	high	low	high	low	high

Action (byte\_0 - 1)

Action	Classification	Content
1	Set	Change setting to desired value.
2	Get	Read projector internal setup value.
4	Increment	Increment setup value by 1.
5	Decrement	Decrement setup value by 1.
6	Execute	Run a command.

#### Requesting projector status (Get command)

(1) Send the following request code from the PC to the projector.

*Header + Command data ('02H' + '00H' + type (2 bytes) + '00H' + '00H')*

(2) The projector returns the response code '1DH' + data (2 bytes) to the PC.

#### Changing the projector settings (Set command)

(1) Send the following setting code from the PC to the projector.

*Header + Command data ('01H' + '00H' + type (2 bytes) + setting code (2 bytes))*

(2) The projector changes the setting based on the above setting code.

(3) The projector returns the response code '06H' to the PC.

#### Using the projector default settings (Reset Command)

(1) The PC sends the following default setting code to the projector.

*Header + Command data ('06H' + '00H' + type (2 bytes) + '00H' + '00H')*

(2) The projector changes the specified setting to the default value.

(3) The projector returns the response code '06H' to the PC.

#### Increasing the projector setting value (Increment command)

(1) The PC sends the following increment code to the projector.

*Header + Command data ('04H' + '00H' + type (2 bytes) + '00H' + '00H')*

(2) The projector increases the setting value on the above setting code.

(3) The projector returns the response code '06H' to the PC.



### Decreasing the projector setting value (Decrement command)

- (1) The PC sends the following decrement code to the projector.  
*Header + Command data ('05H' + '00H' + type (2 bytes) + '00H' + '00H')*
- (2) The projector decreases the setting value on the above setting code.
- (3) The projector returns the response code '06H' to the PC.

### When the projector cannot understand the received command

When the projector cannot understand the received command, the error code '15H' is sent back to the PC.

Sometimes the projector cannot properly receive the command. In such a case, the command is not executed and the error code '15H' is sent back to the PC. If this error code is returned, send the same command again.

### When the projector cannot execute the received command.

When the projector cannot execute the received command, the error code '1CH' + 'xxxxH' is sent back to the PC.

When the data length is greater than indicated by the data length code, the projector ignore the excess data code. Conversely when the data length is shorter than indicated by the data length code, an error code will be returned to the PC.

### When authentication error occurred.

When authentication error occurred, the error code the '1FH' + '0400H' is sent back to the PC.

**NOTE** • Operation cannot be guaranteed when the projector receives an undefined command or data.

- Provide an interval of at least 40ms between the response code and any other code.
- Commands are not accepted during warm-up.

## [TCP #9715]

### 1. Protocol

Consist of header (1 byte) + data length (1 byte) + command data (13 bytes) + check sum (1 bytes) + connection ID (1 byte).

### 2. Header

02, Fixed

### 3. Data Length

Network control commands byte length (0D, Fixed)

### 4. Command data

Network control commands that start with BE EF (13bytes).

### 5. Check Sum

This is the value to make zero on the addition of the lower 8 bits from the header to the checksum.

### 6. Connection ID

Random value from 0 to 255 (This value is attached to the reply data).

## 7. Reply Data

The connection ID (the data is same as the connection ID data on the sending data format) is attached to the Network control commands reply data.

ACK reply: '06H' + 'xxH'

NAK reply: '15H' + 'xxH'

Error reply: '1CH' + 'xxxxH' + 'xxH'

Data reply: '1DH' + 'xxxxH' + 'xxH'

Projector busy reply: '1FH' + 'xxxxH' + 'xxH'

Authentication error reply: '1FH' + '0400H' + 'xxH'

('xxH' : connection ID)

## Automatic Connection Break

The TCP connection will be automatically disconnected after there is no communication for 30 seconds after being established.

## Authentication

The projector does not accept commands without authentication success when authentication is enabled. The projector uses a challenge response type authentication with an MD5 (Message Digest 5) algorithm. When the projector is using a LAN, a random 8 bytes will be returned if authentication is enabled. Bind this received 8 bytes and the authentication password and digest this data with the MD5 algorithm and add this in front of the commands to send.

Following is a sample if the authentication password is set to "password" and the random 8 bytes are "a572f60c".

- 1) Select the projector.
- 2) Receive the random 8 bytes "a572f60c" from the projector.
- 3) Bind the random 8 bytes "a572f60c" and the authentication password "password" and it becomes "a572f60cpassword".
- 4) Digest this bind "a572f60cpassword" with MD5 algorithm.  
It will be "e3d97429adffa11bce1f7275813d4bde".
- 5) Add this "e3d97429adffa11bce1f7275813d4bde" in front of the commands and send the data.  
Send "e3d97429adffa11bce1f7275813d4bde"+command.
- 6) When the sending data is correct, the command will be performed and the reply data will be returned. Otherwise, an authentication error will be returned.

**NOTE** • As for the transmission of the second or subsequent commands, the authentication data can be omitted when the same connection.

## RS-232C communication / Network command table

Names	Operation Type	Header				Command Data			
						CRC	Action	Type	Setting Code
Power	Set	Turn off	BE EF	03	06 00	2A D3	01 00	00 60	00 00
		Turn on	BE EF	03	06 00	BA D2	01 00	00 60	01 00
	Get		BE EF	03	06 00	19 D3	02 00	00 60	00 00
		[Example return]	00 00 [Off]	01 00 [On]	02 00 [Cool down]				
Input Source	Set	COMPUTER1	BE EF	03	06 00	FE D2	01 00	00 20	00 00
		COMPUTER2	BE EF	03	06 00	3E D0	01 00	00 20	04 00
		COMPONENT	BE EF	03	06 00	AE D1	01 00	00 20	05 00
		S-VIDEO	BE EF	03	06 00	9E D3	01 00	00 20	02 00
		VIDEO	BE EF	03	06 00	6E D3	01 00	00 20	01 00
	MIU	BE EF	03	06 00	5E D1	01 00	00 20	06 00	
Error Status	Get		BE EF	03	06 00	CD D2	02 00	00 20	00 00
		[Example return]	00 00 [Normal]	01 00 [Cover error]	02 00 [Fan error]	03 00 [Lamp error]	04 00 [Temp error]	05 00 [Air flow error]	06 00 [Lamp time error]
BRIGHTNESS	Get		BE EF	03	06 00	89 D2	02 00	03 20	00 00
		Increment	BE EF	03	06 00	EF D2	04 00	03 20	00 00
		Decrement	BE EF	03	06 00	3E D3	05 00	03 20	00 00
BRIGHTNESS Reset	Execute		BE EF	03	06 00	58 D3	06 00	00 70	00 00
CONTRAST	Get		BE EF	03	06 00	FD D3	02 00	04 20	00 00
		Increment	BE EF	03	06 00	9B D3	04 00	04 20	00 00
		Decrement	BE EF	03	06 00	4A D2	05 00	04 20	00 00
CONTRAST Reset	Execute		BE EF	03	06 00	A4 D2	06 00	01 70	00 00
PICTURE MODE	Set	NORMAL	BE EF	03	06 00	23 F6	01 00	BA 30	00 00
		CINEMA	BE EF	03	06 00	B3 F7	01 00	BA 30	01 00
		DYNAMIC	BE EF	03	06 00	E3 F4	01 00	BA 30	04 00
		BOARD(BLACK)	BE EF	03	06 00	E3 EF	01 00	BA 30	20 00
		BOARD(GREEN)	BE EF	03	06 00	73 EE	01 00	BA 30	21 00
		WHITEBOARD	BE EF	03	06 00	83 EE	01 00	BA 30	22 00
	DAYTIME	BE EF	03	06 00	E3 C7	01 00	BA 30	40 00	
GAMMA	Get		BE EF	03	06 00	10 F6	02 00	BA 30	00 00
		[Example return]	00 00 [Normal]	01 00 [Cinema]	04 00 [Dynamic]	10 00 [Custom]	20 00 [BOARD(BLACK)]	21 00 [BOARD(GREEN)]	22 00 [WHITEBOARD]
GAMMA	Set	#1 DEFAULT	BE EF	03	06 00	07 E9	01 00	A1 30	20 00
		#1 CUSTOM	BE EF	03	06 00	07 FD	01 00	A1 30	10 00
		#2 DEFAULT	BE EF	03	06 00	97 E8	01 00	A1 30	21 00
		#2 CUSTOM	BE EF	03	06 00	97 FC	01 00	A1 30	11 00
		#3 DEFAULT	BE EF	03	06 00	67 E8	01 00	A1 30	22 00
		#3 CUSTOM	BE EF	03	06 00	67 FC	01 00	A1 30	12 00
		#4 DEFAULT	BE EF	03	06 00	F7 E9	01 00	A1 30	23 00
		#4 CUSTOM	BE EF	03	06 00	F7 FD	01 00	A1 30	13 00
		#5 DEFAULT	BE EF	03	06 00	C7 EB	01 00	A1 30	24 00
		#5 CUSTOM	BE EF	03	06 00	C7 FF	01 00	A1 30	14 00
	#6 DEFAULT	BE EF	03	06 00	57 EA	01 00	A1 30	25 00	
#6 CUSTOM	BE EF	03	06 00	57 FE	01 00	A1 30	15 00		
GAMMA	Get		BE EF	03	06 00	F4 F0	02 00	A1 30	00 00

## RS-232C communication / Network command table (continued)

Names	Operation Type	Header				Command Data			
						CRC	Action	Type	Setting Code
User Gamma Pattern	Set	Off	BE EF	03	06 00	FB FA	01 00	80 30	00 00
		9 steps gray scale	BE EF	03	06 00	6B FB	01 00	80 30	01 00
		15 steps gray scale	BE EF	03	06 00	9B FB	01 00	80 30	02 00
		Ramp	BE EF	03	06 00	0B FA	01 00	80 30	03 00
		Get	BE EF	03	06 00	C8 FA	02 00	80 30	00 00
User Gamma Point 1		Get	BE EF	03	06 00	08 FE	02 00	90 30	00 00
		Increment	BE EF	03	06 00	6E FE	04 00	90 30	00 00
		Decrement	BE EF	03	06 00	BF FF	05 00	90 30	00 00
User Gamma Point 2		Get	BE EF	03	06 00	F4 FF	02 00	91 30	00 00
		Increment	BE EF	03	06 00	92 FF	04 00	91 30	00 00
		Decrement	BE EF	03	06 00	43 FE	05 00	91 30	00 00
User Gamma Point 3		Get	BE EF	03	06 00	80 FF	02 00	92 30	00 00
		Increment	BE EF	03	06 00	D6 FF	04 00	92 30	00 00
		Decrement	BE EF	03	06 00	07 FE	05 00	92 30	00 00
User Gamma Point 4		Get	BE EF	03	06 00	4C FE	02 00	93 30	00 00
		Increment	BE EF	03	06 00	2A FE	04 00	93 30	00 00
		Decrement	BE EF	03	06 00	FB FF	05 00	93 30	00 00
User Gamma Point 5		Get	BE EF	03	06 00	38 FF	02 00	94 30	00 00
		Increment	BE EF	03	06 00	5E FF	04 00	94 30	00 00
		Decrement	BE EF	03	06 00	8F FE	05 00	94 30	00 00
User Gamma Point 6		Get	BE EF	03	06 00	C4 FE	02 00	95 30	00 00
		Increment	BE EF	03	06 00	A2 FE	04 00	95 30	00 00
		Decrement	BE EF	03	06 00	73 FF	05 00	95 30	00 00
User Gamma Point 7		Get	BE EF	03	06 00	80 FE	02 00	96 30	00 00
		Increment	BE EF	03	06 00	E6 FE	04 00	96 30	00 00
		Decrement	BE EF	03	06 00	37 FF	05 00	96 30	00 00
User Gamma Point 8		Get	BE EF	03	06 00	7C FF	02 00	97 30	00 00
		Increment	BE EF	03	06 00	1A FF	04 00	97 30	00 00
		Decrement	BE EF	03	06 00	CB FE	05 00	97 30	00 00
COLOR TEMP	Set	HIGH	BE EF	03	06 00	0B F5	01 00	B0 30	03 00
		CUSTOM-1 (HIGH)	BE EF	03	06 00	CB F8	01 00	B0 30	13 00
		MID	BE EF	03	06 00	9B F4	01 00	B0 30	02 00
		CUSTOM-2 (MID)	BE EF	03	06 00	5B F9	01 00	B0 30	12 00
		LOW	BE EF	03	06 00	6B F4	01 00	B0 30	01 00
		CUSTOM-3 (LOW)	BE EF	03	06 00	AB F9	01 00	B0 30	11 00
		Hi-BRIGHT-1	BE EF	03	06 00	3B F2	01 00	B0 30	08 00
		CUSTOM-4 (Hi-BRIGHT-1)	BE EF	03	06 00	FB FF	01 00	B0 30	18 00
		Hi-BRIGHT-2	BE EF	03	06 00	AB F3	01 00	B0 30	09 00
		CUSTOM-5 (Hi-BRIGHT-2)	BE EF	03	06 00	6B FE	01 00	B0 30	19 00
		Hi-BRIGHT-3	BE EF	03	06 00	5B F3	01 00	B0 30	0A 00
		CUSTOM-6 (Hi-BRIGHT-3)	BE EF	03	06 00	9B FE	01 00	B0 30	1A 00
				Get	BE EF	03	06 00	C8 F5	02 00
COLOR TEMP GAIN R		Get	BE EF	03	06 00	34 F4	02 00	B1 30	00 00
		Increment	BE EF	03	06 00	52 F4	04 00	B1 30	00 00
		Decrement	BE EF	03	06 00	83 F5	05 00	B1 30	00 00
COLOR TEMP GAIN G		Get	BE EF	03	06 00	70 F4	02 00	B2 30	00 00
		Increment	BE EF	03	06 00	16 F4	04 00	B2 30	00 00
		Decrement	BE EF	03	06 00	C7 F5	05 00	B2 30	00 00

(continued on next page)

RS-232C communication / Network command table (continued)

Names	Operation Type	Header				Command Data			
						CRC	Action	Type	Setting Code
COLOR TEMP GAIN B	Get	BE EF	03	06 00	8C F5	02 00	B3 30	00 00	
	Increment	BE EF	03	06 00	EA F5	04 00	B3 30	00 00	
	Decrement	BE EF	03	06 00	3B F4	05 00	B3 30	00 00	
COLOR TEMP OFFSET R	Get	BE EF	03	06 00	04 F5	02 00	B5 30	00 00	
	Increment	BE EF	03	06 00	62 F5	04 00	B5 30	00 00	
	Decrement	BE EF	03	06 00	B3 F4	05 00	B5 30	00 00	
COLOR TEMP OFFSET G	Get	BE EF	03	06 00	40 F5	02 00	B6 30	00 00	
	Increment	BE EF	03	06 00	26 F5	04 00	B6 30	00 00	
	Decrement	BE EF	03	06 00	F7 F4	05 00	B6 30	00 00	
COLOR TEMP OFFSET B	Get	BE EF	03	06 00	BC F4	02 00	B7 30	00 00	
	Increment	BE EF	03	06 00	DA F4	04 00	B7 30	00 00	
	Decrement	BE EF	03	06 00	0B F5	05 00	B7 30	00 00	
COLOR	Get	BE EF	03	06 00	B5 72	02 00	02 22	00 00	
	Increment	BE EF	03	06 00	D3 72	04 00	02 22	00 00	
	Decrement	BE EF	03	06 00	02 73	05 00	02 22	00 00	
COLOR Reset	Execute	BE EF	03	06 00	80 D0	06 00	0A 70	00 00	
TINT	Get	BE EF	03	06 00	49 73	02 00	03 22	00 00	
	Increment	BE EF	03	06 00	2F 73	04 00	03 22	00 00	
	Decrement	BE EF	03	06 00	FE 72	05 00	03 22	00 00	
TINT Reset	Execute	BE EF	03	06 00	7C D1	06 00	0B 70	00 00	
SHARPNESS	Get	BE EF	03	06 00	F1 72	02 00	01 22	00 00	
	Increment	BE EF	03	06 00	97 72	04 00	01 22	00 00	
	Decrement	BE EF	03	06 00	46 73	05 00	01 22	00 00	
SHARPNESS Reset	Execute	BE EF	03	06 00	C4 D0	06 00	09 70	00 00	
MY MEMORY Load	Set	1	BE EF	03	06 00	0E D7	01 00	14 20	00 00
		2	BE EF	03	06 00	9E D6	01 00	14 20	01 00
		3	BE EF	03	06 00	6E D6	01 00	14 20	02 00
		4	BE EF	03	06 00	FE D7	01 00	14 20	03 00
MY MEMORY Save	Set	1	BE EF	03	06 00	F2 D6	01 00	15 20	00 00
		2	BE EF	03	06 00	62 D7	01 00	15 20	01 00
		3	BE EF	03	06 00	92 D7	01 00	15 20	02 00
		4	BE EF	03	06 00	02 D6	01 00	15 20	03 00
PROGRESSIVE	Set	TURN OFF	BE EF	03	06 00	4A 72	01 00	07 22	00 00
		TV	BE EF	03	06 00	DA 73	01 00	07 22	01 00
		FILM	BE EF	03	06 00	2A 73	01 00	07 22	02 00
	Get	BE EF	03	06 00	79 72	02 00	07 22	00 00	
VIDEO NR	Set	LOW	BE EF	03	06 00	26 72	01 00	06 22	01 00
		MID	BE EF	03	06 00	D6 72	01 00	06 22	02 00
		HIGH	BE EF	03	06 00	46 73	01 00	06 22	03 00
	Get	BE EF	03	06 00	85 73	02 00	06 22	00 00	
ASPECT	Set	4:3	BE EF	03	06 00	9E D0	01 00	08 20	00 00
		16:9	BE EF	03	06 00	0E D1	01 00	08 20	01 00
		14:9	BE EF	03	06 00	CE D6	01 00	08 20	09 00
		SMALL	BE EF	03	06 00	FE D1	01 00	08 20	02 00
	NORMAL	BE EF	03	06 00	5E DD	01 00	08 20	10 00	
Get	BE EF	03	06 00	AD D0	02 00	08 20	00 00		

(continued on next page)

## RS-232C communication / Network command table (continued)

Names	Operation Type	Header				Command Data			
						CRC	Action	Type	Setting Code
OVER SCAN	Get	BE EF	03	06 00	91 70	02 00	09 22	00 00	
	Increment	BE EF	03	06 00	F7 70	04 00	09 22	00 00	
	Decrement	BE EF	03	06 00	26 71	05 00	09 22	00 00	
OVER SCAN Reset	Execute	BE EF	03	06 00	EC D9	06 00	27 70	00 00	
V POSITION	Get	BE EF	03	06 00	0D 83	02 00	00 21	00 00	
	Increment	BE EF	03	06 00	6B 83	04 00	00 21	00 00	
	Decrement	BE EF	03	06 00	BA 82	05 00	00 21	00 00	
V POSITION Reset	Execute	BE EF	03	06 00	E0 D2	06 00	02 70	00 00	
H POSITION	Get	BE EF	03	06 00	F1 82	02 00	01 21	00 00	
	Increment	BE EF	03	06 00	97 82	04 00	01 21	00 00	
	Decrement	BE EF	03	06 00	46 83	05 00	01 21	00 00	
H POSITION Reset	Execute	BE EF	03	06 00	1C D3	06 00	03 70	00 00	
H PHASE	Get	BE EF	03	06 00	49 83	02 00	03 21	00 00	
	Increment	BE EF	03	06 00	2F 83	04 00	03 21	00 00	
	Decrement	BE EF	03	06 00	FE 82	05 00	03 21	00 00	
H SIZE	Get	BE EF	03	06 00	B5 82	02 00	02 21	00 00	
	Increment	BE EF	03	06 00	D3 82	04 00	02 21	00 00	
	Decrement	BE EF	03	06 00	02 83	05 00	02 21	00 00	
H SIZE Reset	Execute	BE EF	03	06 00	68 D2	06 00	04 70	00 00	
AUTO ADJUST	Execute	BE EF	03	06 00	91 D0	06 00	0A 20	00 00	
COLOR SPACE	Set	AUTO	BE EF	03	06 00	0E 72	01 00	04 22	00 00
		RGB	BE EF	03	06 00	9E 73	01 00	04 22	01 00
		SMPTE240	BE EF	03	06 00	6E 73	01 00	04 22	02 00
		REC709	BE EF	03	06 00	FE 72	01 00	04 22	03 00
		REC601	BE EF	03	06 00	CE 70	01 00	04 22	04 00
	Get	BE EF	03	06 00	3D 72	02 00	04 22	00 00	
COMPONENT	Set	COMPONENT	BE EF	03	06 00	4A D7	01 00	17 20	00 00
		SCART RGB	BE EF	03	06 00	DA D6	01 00	17 20	01 00
		Get	BE EF	03	06 00	79 D7	02 00	17 20	00 00
C-VIDEO FORMAT	Set	AUTO	BE EF	03	06 00	A2 70	01 00	11 22	0A 00
		NTSC	BE EF	03	06 00	C2 74	01 00	11 22	04 00
		PAL	BE EF	03	06 00	52 75	01 00	11 22	05 00
		SECAM	BE EF	03	06 00	52 70	01 00	11 22	09 00
		NTSC4.43	BE EF	03	06 00	62 77	01 00	11 22	02 00
		M-PAL	BE EF	03	06 00	C2 71	01 00	11 22	08 00
		N-PAL	BE EF	03	06 00	32 74	01 00	11 22	07 00
	Get	BE EF	03	06 00	31 76	02 00	11 22	00 00	
S-VIDEO FORMAT	Set	AUTO	BE EF	03	06 00	E6 70	01 00	12 22	0A 00
		NTSC	BE EF	03	06 00	86 74	01 00	12 22	04 00
		PAL	BE EF	03	06 00	16 75	01 00	12 22	05 00
		SECAM	BE EF	03	06 00	16 70	01 00	12 22	09 00
		NTSC4.43	BE EF	03	06 00	26 77	01 00	12 22	02 00
		M-PAL	BE EF	03	06 00	86 71	01 00	12 22	08 00
		N-PAL	BE EF	03	06 00	76 74	01 00	12 22	07 00
	Get	BE EF	03	06 00	75 76	02 00	12 22	00 00	

(continued on next page)

RS-232C communication / Network command table (continued)

Names	Operation Type	Header					Command Data		
		CRC	Action	Type	Setting Code				
FRAME LOCK – COMPUTER1	Set	TURN OFF	BE EF	03	06 00	3B C2	01 00	50 30	00 00
		TURN ON	BE EF	03	06 00	AB C3	01 00	50 30	01 00
	Get	BE EF	03	06 00	08 C2	02 00	50 30	00 00	
FRAME LOCK – COMPUTER2	Set	TURN OFF	BE EF	03	06 00	7F C2	01 00	54 30	00 00
		TURN ON	BE EF	03	06 00	EF C3	01 00	54 30	01 00
	Get	BE EF	03	06 00	4C C2	02 00	54 30	00 00	
COMPUTER IN1	Set	SYNC ON G ON	BE EF	03	06 00	CE D6	01 00	10 20	03 00
		SYNC ON G OFF	BE EF	03	06 00	5E D7	01 00	10 20	02 00
	Get	BE EF	03	06 00	0D D6	02 00	10 20	00 00	
COMPUTER IN2	Set	SYNC ON G ON	BE EF	03	06 00	32 D7	01 00	11 20	03 00
		SYNC ON G OFF	BE EF	03	06 00	A2 D6	01 00	11 20	02 00
	Get	BE EF	03	06 00	F1 D7	02 00	11 20	00 00	
KEYSTONE V	Get	BE EF	03	06 00	B9 D3	02 00	07 20	00 00	
	Increment	BE EF	03	06 00	DF D3	04 00	07 20	00 00	
	Decrement	BE EF	03	06 00	0E D2	05 00	07 20	00 00	
KEYSTONE V Reset	Execute	BE EF	03	06 00	08 D0	06 00	0C 70	00 00	
AUTO KEYSTONE EXECUTE	Execute	BE EF	03	06 00	E5 D1	06 00	0D 20	00 00	
WHISPER	Set	NORMAL	BE EF	03	06 00	3B 23	01 00	00 33	00 00
		WHISPER	BE EF	03	06 00	AB 22	01 00	00 33	01 00
	Get	BE EF	03	06 00	08 23	02 00	00 33	00 00	
MIRROR	Set	NORMAL	BE EF	03	06 00	C7 D2	01 00	01 30	00 00
		H:INVERT	BE EF	03	06 00	57 D3	01 00	01 30	01 00
		V:INVERT	BE EF	03	06 00	A7 D3	01 00	01 30	02 00
		H&V:INVERT	BE EF	03	06 00	37 D2	01 00	01 30	03 00
	Get	BE EF	03	06 00	F4 D2	02 00	01 30	00 00	
VOLUME-COMPUTER1	Get	BE EF	03	06 00	CD CC	02 00	60 20	00 00	
	Increment	BE EF	03	06 00	AB CC	04 00	60 20	00 00	
	Decrement	BE EF	03	06 00	7A CD	05 00	60 20	00 00	
VOLUME-COMPUTER2	Get	BE EF	03	06 00	FD CD	02 00	64 20	00 00	
	Increment	BE EF	03	06 00	9B CD	04 00	64 20	00 00	
	Decrement	BE EF	03	06 00	4A CC	05 00	64 20	00 00	
VOLUME-COMPONENT	Get	BE EF	03	06 00	01 CC	02 00	65 20	00 00	
	Increment	BE EF	03	06 00	67 CC	04 00	65 20	00 00	
	Decrement	BE EF	03	06 00	B6 CD	05 00	65 20	00 00	
VOLUME-S-Video	Get	BE EF	03	06 00	75 CD	02 00	62 20	00 00	
	Increment	BE EF	03	06 00	13 CD	04 00	62 20	00 00	
	Decrement	BE EF	03	06 00	C2 CC	05 00	62 20	00 00	
VOLUME-Video	Get	BE EF	03	06 00	31 CD	02 00	61 20	00 00	
	Increment	BE EF	03	06 00	57 CD	04 00	61 20	00 00	
	Decrement	BE EF	03	06 00	86 CC	05 00	61 20	00 00	
VOLUME – MIU	Get	BE EF	03	06 00	45 CC	02 00	66 20	00 00	
	Increment	BE EF	03	06 00	23 CC	04 00	66 20	00 00	
	Decrement	BE EF	03	06 00	F2 CD	05 00	66 20	00 00	
MUTE	Set	TURN OFF	BE EF	03	06 00	46 D3	01 00	02 20	00 00
		TURN ON	BE EF	03	06 00	D6 D2	01 00	02 20	01 00
	Get	BE EF	03	06 00	75 D3	02 00	02 20	00 00	

(continued on next page)

## RS-232C communication / Network command table (continued)

Names	Operation Type	Header				Command Data			
						CRC	Action	Type	Setting Code
SPEAKER	Set	TURN ON	BE EF	03	06 00	FE D4	01 00	1C 20	01 00
		TURN OFF	BE EF	03	06 00	6E D5	01 00	1C 20	00 00
	Get	BE EF	03	06 00	5D D5	02 00	1C 20	00 00	
AUDIO-COMPUTER1	Set	AUDIO1	BE EF	03	06 00	6E DC	01 00	30 20	01 00
		AUDIO2	BE EF	03	06 00	9E DC	01 00	30 20	02 00
		AUDIO3	BE EF	03	06 00	0E DD	01 00	30 20	03 00
	Turn off	BE EF	03	06 00	FE DD	01 00	30 20	00 00	
	Get	BE EF	03	06 00	CD DD	02 00	30 20	00 00	
AUDIO-COMPUTER2	Set	AUDIO1	BE EF	03	06 00	5E DD	01 00	34 20	01 00
		AUDIO2	BE EF	03	06 00	AE DD	01 00	34 20	02 00
		AUDIO3	BE EF	03	06 00	3E DC	01 00	34 20	03 00
	Turn off	BE EF	03	06 00	CE DC	01 00	34 20	00 00	
	Get	BE EF	03	06 00	FD DC	02 00	34 20	00 00	
AUDIO-COMPONENT	Set	AUDIO1	BE EF	03	06 00	A2 DC	01 00	35 20	01 00
		AUDIO2	BE EF	03	06 00	52 DC	01 00	35 20	02 00
		AUDIO3	BE EF	03	06 00	C2 DD	01 00	35 20	03 00
	Turn off	BE EF	03	06 00	32 DD	01 00	35 20	00 00	
	Get	BE EF	03	06 00	01 DD	02 00	35 20	00 00	
AUDIO-S-VIDEO	Set	AUDIO1	BE EF	03	06 00	D6 DD	01 00	32 20	01 00
		AUDIO2	BE EF	03	06 00	26 DD	01 00	32 20	02 00
		AUDIO3	BE EF	03	06 00	B6 DC	01 00	32 20	03 00
	Turn off	BE EF	03	06 00	46 DC	01 00	32 20	00 00	
	Get	BE EF	03	06 00	75 DC	02 00	32 20	00 00	
AUDIO-VIDEO	Set	AUDIO1	BE EF	03	06 00	92 DD	01 00	31 20	01 00
		AUDIO2	BE EF	03	06 00	62 DD	01 00	31 20	02 00
		AUDIO3	BE EF	03	06 00	F2 DC	01 00	31 20	03 00
	Turn off	BE EF	03	06 00	02 DC	01 00	31 20	00 00	
	Get	BE EF	03	06 00	31 DC	02 00	31 20	00 00	
AUDIO-MIU	Set	AUDIO1	BE EF	03	06 00	E6 DC	01 00	36 20	01 00
		AUDIO2	BE EF	03	06 00	16 DC	01 00	36 20	02 00
		AUDIO3	BE EF	03	06 00	86 DD	01 00	36 20	03 00
		MIU	BE EF	03	06 00	B6 D0	01 00	36 20	10 00
	Turn off	BE EF	03	06 00	76 DD	01 00	36 20	00 00	
	Get	BE EF	03	06 00	45 DD	02 00	36 20	00 00	
REMOTE FREQ. NORMAL	Set	Off	BE EF	03	06 00	FF 3D	01 00	30 26	00 00
		On	BE EF	03	06 00	6F 3C	01 00	30 26	01 00
	Get	BE EF	03	06 00	CC 3D	02 00	30 26	00 00	
REMOTE FREQ. HIGH	Set	Off	BE EF	03	06 00	03 3C	01 00	31 26	00 00
		On	BE EF	03	06 00	93 3D	01 00	31 26	01 00
	Get	BE EF	03	06 00	30 3C	02 00	31 26	00 00	

(continued on next page)



## RS-232C communication / Network command table (continued)

Names	Operation Type	Header					Command Data		
							CRC	Action	Type
LANGUAGE	Set	ENGLISH	BE EF	03	06 00	F7 D3	01 00	05 30	00 00
		FRANÇAIS	BE EF	03	06 00	67 D2	01 00	05 30	01 00
		DEUTSCH	BE EF	03	06 00	97 D2	01 00	05 30	02 00
		ESPAÑOL	BE EF	03	06 00	07 D3	01 00	05 30	03 00
		ITALIANO	BE EF	03	06 00	37 D1	01 00	05 30	04 00
		NORSK	BE EF	03	06 00	A7 D0	01 00	05 30	05 00
		NEDERLANDS	BE EF	03	06 00	57 D0	01 00	05 30	06 00
		PORTUGUÊS	BE EF	03	06 00	C7 D1	01 00	05 30	07 00
		日本語	BE EF	03	06 00	37 D4	01 00	05 30	08 00
		简体中文	BE EF	03	06 00	A7 D5	01 00	05 30	09 00
		繁體中文	BE EF	03	06 00	37 DE	01 00	05 30	10 00
		한글	BE EF	03	06 00	57 D5	01 00	05 30	0A 00
		SVENSKA	BE EF	03	06 00	C7 D4	01 00	05 30	0B 00
		РУССКИЙ	BE EF	03	06 00	F7 D6	01 00	05 30	0C 00
	SUOMI	BE EF	03	06 00	67 D7	01 00	05 30	0D 00	
POLSKI	BE EF	03	06 00	97 D7	01 00	05 30	0E 00		
TÜRKÇE	BE EF	03	06 00	07 D6	01 00	05 30	0F 00		
	Get	BE EF	03	06 00	C4 D3	02 00	05 30	00 00	
MENU POSITION H	Get	BE EF	03	06 00	04 D7	02 00	15 30	00 00	
	Increment	BE EF	03	06 00	62 D7	04 00	15 30	00 00	
	Decrement	BE EF	03	06 00	B3 D6	05 00	15 30	00 00	
MENU POSITION H Reset	Execute	BE EF	03	06 00	DC C6	06 00	43 70	00 00	
MENU POSITION V	Get	BE EF	03	06 00	40 D7	02 00	16 30	00 00	
	Increment	BE EF	03	06 00	26 D7	04 00	16 30	00 00	
	Decrement	BE EF	03	06 00	F7 D6	05 00	16 30	00 00	
MENU POSITION V Reset	Execute	BE EF	03	06 00	A8 C7	06 00	44 70	00 00	
BLANK	Set	MyScreen	BE EF	03	06 00	FB CA	01 00	00 30	20 00
		ORIGINAL	BE EF	03	06 00	FB E2	01 00	00 30	40 00
		BLUE	BE EF	03	06 00	CB D3	01 00	00 30	03 00
		WHITE	BE EF	03	06 00	6B D0	01 00	00 30	05 00
	BLACK	BE EF	03	06 00	9B D0	01 00	00 30	06 00	
	Get	BE EF	03	06 00	08 D3	02 00	00 30	00 00	
BLANK On/Off	Set	TURN OFF	BE EF	03	06 00	FB D8	01 00	20 30	00 00
		TURN ON	BE EF	03	06 00	6B D9	01 00	20 30	01 00
	Get	BE EF	03	06 00	C8 D8	02 00	20 30	00 00	
START UP	Set	MyScreen	BE EF	03	06 00	CB CB	01 00	04 30	20 00
		ORIGINAL	BE EF	03	06 00	0B D2	01 00	04 30	00 00
		TURN OFF	BE EF	03	06 00	9B D3	01 00	04 30	01 00
	Get	BE EF	03	06 00	38 D2	02 00	04 30	00 00	
MyScreen LOCK	Set	TURN OFF	BE EF	03	06 00	3B EF	01 00	C0 30	00 00
		TURN ON	BE EF	03	06 00	AB EE	01 00	C0 30	01 00
	Get	BE EF	03	06 00	08 EF	02 00	C0 30	00 00	
MESSAGE	Set	TURN OFF	BE EF	03	06 00	8F D6	01 00	17 30	00 00
		TURN ON	BE EF	03	06 00	1F D7	01 00	17 30	01 00
	Get	BE EF	03	06 00	BC D6	02 00	17 30	00 00	
AUTO SEARCH	Set	TURN OFF	BE EF	03	06 00	B6 D6	01 00	16 20	00 00
		TURN ON	BE EF	03	06 00	26 D7	01 00	16 20	01 00
	Get	BE EF	03	06 00	85 D6	02 00	16 20	00 00	

(continued on next page)

## RS-232C communication / Network command table (continued)

Names	Operation Type	Header				Command Data			
						CRC	Action	Type	Setting Code
AUTO KEYSTONE	Set	TURN OFF	BE EF	03	06 00	EA D1	01 00	0F 20	00 00
		TURN ON	BE EF	03	06 00	7A D0	01 00	0F 20	01 00
	Get	BE EF	03	06 00	D9 D1	02 00	0F 20	00 00	
AUTO ON	Set	TURN OFF	BE EF	03	06 00	3B 89	01 00	20 31	00 00
		TURN ON	BE EF	03	06 00	AB 88	01 00	20 31	01 00
	Get	BE EF	03	06 00	08 89	02 00	20 31	00 00	
AUTO OFF	Get	BE EF	03	06 00	08 86	02 00	10 31	00 00	
	Increment	BE EF	03	06 00	6E 86	04 00	10 31	00 00	
	Decrement	BE EF	03	06 00	BE 87	05 00	10 31	00 00	
LAMP TIME	Get	BE EF	03	06 00	C2 FF	02 00	90 10	00 00	
LAMP TIME Reset	Execute	BE EF	03	06 00	58 DC	06 00	30 70	00 00	
FILTER TIME	Get	BE EF	03	06 00	C2 F0	02 00	A0 10	00 00	
FILER TIME Reset	Execute	BE EF	03	06 00	98 C6	06 00	40 70	00 00	
MY BUTTON-1	COMPUTER1	BE EF	03	06 00	3A 33	01 00	00 36	00 00	
	COMPUTER2	BE EF	03	06 00	FA 31	01 00	00 36	04 00	
	COMPONENT	BE EF	03	06 00	6A 30	01 00	00 36	05 00	
	S-VIDEO	BE EF	03	06 00	5A 32	01 00	00 36	02 00	
	VIDEO	BE EF	03	06 00	AA 32	01 00	00 36	01 00	
	MIU	BE EF	03	06 00	9A 30	01 00	00 36	06 00	
	INFORMATION	BE EF	03	06 00	FA 3E	01 00	00 36	10 00	
	AUTO KEYSTONE V	BE EF	03	06 00	6A 3F	01 00	00 36	11 00	
	MY MEMORY	BE EF	03	06 00	9A 3F	01 00	00 36	12 00	
	PICTURE MODE	BE EF	03	06 00	0A 3E	01 00	00 36	13 00	
	FILTER RESET	BE EF	03	06 00	3A 3C	01 00	00 36	14 00	
	e-SHOT	BE EF	03	06 00	5A 3D	01 00	00 36	16 00	
	VOLUME +	BE EF	03	06 00	CA 3C	01 00	00 36	17 00	
	VOLUME -	BE EF	03	06 00	3A 39	01 00	00 36	18 00	
	LIVE MODE	BE EF	03	06 00	FA 2A	01 00	00 36	20 00	
	THUMBNAIL	BE EF	03	06 00	6A 2B	01 00	00 36	21 00	
	SLIDE SHOW	BE EF	03	06 00	9A 2B	01 00	00 36	22 00	
	DIRECTORY	BE EF	03	06 00	0A 2A	01 00	00 36	23 00	
	REMOVE MEDIA	BE EF	03	06 00	3A 28	01 00	00 36	24 00	
	Get	BE EF	03	06 00	09 33	02 00	00 36	00 00	
MY BUTTON-2	COMPUTER1	BE EF	03	06 00	C6 32	01 00	01 36	00 00	
	COMPUTER2	BE EF	03	06 00	06 30	01 00	01 36	04 00	
	COMPONENT	BE EF	03	06 00	96 31	01 00	01 36	05 00	
	S-VIDEO	BE EF	03	06 00	A6 33	01 00	01 36	02 00	
	VIDEO	BE EF	03	06 00	56 33	01 00	01 36	01 00	
	MIU	BE EF	03	06 00	66 31	01 00	01 36	06 00	
	INFORMATION	BE EF	03	06 00	06 3F	01 00	01 36	10 00	
	AUTO KEYSTONE V	BE EF	03	06 00	96 3E	01 00	01 36	11 00	
	MY MEMORY	BE EF	03	06 00	66 3E	01 00	01 36	12 00	
	PICTURE MODE	BE EF	03	06 00	F6 3F	01 00	01 36	13 00	
	FILTER RESET	BE EF	03	06 00	C6 3D	01 00	01 36	14 00	
	e-SHOT	BE EF	03	06 00	A6 3C	01 00	01 36	16 00	
	VOLUME +	BE EF	03	06 00	36 3D	01 00	01 36	17 00	
	VOLUME -	BE EF	03	06 00	C6 38	01 00	01 36	18 00	
	LIVE MODE	BE EF	03	06 00	06 2B	01 00	01 36	20 00	
	THUMBNAIL	BE EF	03	06 00	96 2A	01 00	01 36	21 00	
	SLIDE SHOW	BE EF	03	06 00	66 2A	01 00	01 36	22 00	
	DIRECTORY	BE EF	03	06 00	F6 2B	01 00	01 36	23 00	
	REMOVE MEDIA	BE EF	03	06 00	C6 29	01 00	01 36	24 00	
	Get	BE EF	03	06 00	F5 32	02 00	01 36	00 00	

RS-232C communication / Network command table (continued)

Names	Operation Type	Header				Command Data			
						CRC	Action	Type	Setting Code
MAGNIFY	Get	BE EF	03	06 00	7C D2	02 00	07 30	00 00	
	Increment	BE EF	03	06 00	1A D2	04 00	07 30	00 00	
	Decrement	BE EF	03	06 00	CB D3	05 00	07 30	00 00	
FREEZE	Set	NORMAL	BE EF	03	06 00	83 D2	01 00	02 30	00 00
		FREEZE	BE EF	03	06 00	13 D3	01 00	02 30	01 00
e-SHOT	Set	Get	BE EF	03	06 00	B0 D2	02 00	02 30	00 00
		OFF	BE EF	03	06 00	3A C3	01 00	00 35	00 00
		IMAGE1	BE EF	03	06 00	AA C2	01 00	00 35	01 00
		IMAGE2	BE EF	03	06 00	5A C2	01 00	00 35	02 00
		IMAGE3	BE EF	03	06 00	CA C3	01 00	00 35	03 00
		IMAGE4	BE EF	03	06 00	FA C1	01 00	00 35	04 00
e-SHOT IMAGE1 Delete	Execute	BE EF	03	06 00	09 C3	02 00	00 35	00 00	
e-SHOT IMAGE2 Delete	Execute	BE EF	03	06 00	71 C3	06 00	01 35	00 00	
e-SHOT IMAGE3 Delete	Execute	BE EF	03	06 00	35 C3	06 00	02 35	00 00	
e-SHOT IMAGE4 Delete	Execute	BE EF	03	06 00	C9 C2	06 00	03 35	00 00	
CLOSED CAPTION DISPLAY	Set	TURN OFF	BE EF	03	06 00	BD C3	06 00	04 35	00 00
		TURN ON	BE EF	03	06 00	FA 62	01 00	00 37	00 00
		AUTO	BE EF	03	06 00	6A 63	01 00	00 37	01 00
	Get	BE EF	03	06 00	9A 63	01 00	00 37	02 00	
CLOSED CAPTION MODE	Set	CAPTIONS	BE EF	03	06 00	C9 62	02 00	00 37	00 00
		TEXT	BE EF	03	06 00	06 63	01 00	01 37	00 00
	Get	BE EF	03	06 00	96 62	01 00	01 37	01 00	
CLOSED CAPTION CHANNEL	Set	1	BE EF	03	06 00	35 63	02 00	01 37	00 00
		2	BE EF	03	06 00	D2 62	01 00	02 37	01 00
		3	BE EF	03	06 00	22 62	01 00	02 37	02 00
		4	BE EF	03	06 00	B2 63	01 00	02 37	03 00
	Get	BE EF	03	06 00	82 61	01 00	02 37	04 00	
	Get	BE EF	03	06 00	71 63	02 00	02 37	00 00	

# HITACHI

## Inspire the Next

**Hitachi, Ltd. Japan**  
292 Yoshida-cho  
Totsuka-ku, Yokohama-city  
Kanagawa 244-0817

### **HITACHI EUROPE LTD.**

Consumer Affairs Department  
PO Box 3007  
Maidenhead  
SL6 8ZE

### **UNITED KINGDOM**

Tel: 0870 405 4405  
Email: [consumer.mail@Hitachi-eu.com](mailto:consumer.mail@Hitachi-eu.com)

### **HITACHI EUROPE GmbH**

Munich Office  
Dornacher Strasse 3  
D-85622 Feldkirchen bei München

### **GERMANY**

Tel: +49 -89-991 80-0  
Fax: +49 - 89 - 991 80 -224  
Hotline: +49 - 180 - 551 25 51 (12ct/min.)  
Email: [HSE-DUS.Service@Hitachi-eu.com](mailto:HSE-DUS.Service@Hitachi-eu.com)

### **HITACHI EUROPE SRL**

Via T. Gulli n.39  
20147 MILAN

### **ITALY**

Tel: 02 487861  
Fax: 02 48786381  
Servizio Clienti  
Tel. 02 38073415  
Email: [customerservice.italy@hitachi-eu.com](mailto:customerservice.italy@hitachi-eu.com)

### **HITACHI EUROPE S.A.S**

Lyon Office  
B.P.45, 4 Allée des Sorbiers 69671 Bron Cedex

### **FRANCE**

Tel: 04 72 14 29 70  
Fax: 04 72 14 29 99  
Email: [france.consommateur@hitachi-eu.com](mailto:france.consommateur@hitachi-eu.com)

### **HITACHI EUROPE S.A.**

364, Kifissias Ave. & 1, Delfon Str.  
152 33 Chalandri  
Athens  
**GREECE**

Tel: 1-6837200  
Fax: 1-6835694  
Email: [service.hellas@hitachi-eu.com](mailto:service.hellas@hitachi-eu.com)

### **HITACHI EUROPE S.A.**

Gran Via Carlos III  
86 Planta 5a Edificios  
Trade - Torre Este  
08028 Barcelona

### **SPAIN**

Tel: 93 409 2550  
Fax: 93 491 3513  
Email: [atencion.cliente@hitachi-eu.com](mailto:atencion.cliente@hitachi-eu.com)

### **HITACHI EUROPE AB**

Box 77  
S-164 94 KISTA

### **SWEDEN**

Tel: 08 562 711 00  
Fax: 08 562 711 11  
Email: [csgswe@hitachi-eu.com](mailto:csgswe@hitachi-eu.com)

### **HITACHI EUROPE LTD.**

Norwegian Branch Office  
Strandveien 18  
1366 Lysaker

### **NORWAY**

Tel: 02205 9060  
Fax: 02205 9061  
Email: [csgnor@hitachi-eu.com](mailto:csgnor@hitachi-eu.com)

**HITACHI EUROPE LTD.**  
**BENELUX BRANCHE OFFICE**  
BERGENSESTEENWEG 421  
1600 SINT-PIETERS-LEEUV  
**BELGIUM**  
Tel:0032/2 363 99 01  
Fax:0032/2 363 99 00  
Email:[info@hitachi.be](mailto:info@hitachi.be)

[www.hitachidigitalmedia.com](http://www.hitachidigitalmedia.com)