

Acer P1165E & P5260E Service Manual

FORWORD

For your convenience, all service parts, identified in this manual are available through Acer's normal distribution channels.

In addition to service part number, the generic description has been given, where possible, to allow your service technicians to substitute equivalent components which might be available from other sources.

All orders for service parts will be honored. However, on instance where generic components are considered to be available from several common sources, as would be the case with an industry standard fuse, resistor, or semiconductor, it may be more economical and expeditious to purchase the part locally.

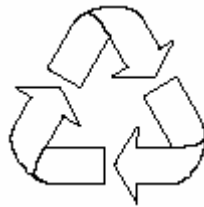

100% Recycled Paper

Date: 2007/10/05

Update History

2007/10/05

First edition completed

Conventions

The following conventions are used in this manual

Screen Messages	Denote actual messages that appear on screen.
Note	Give bits and pieces of additional information related to the current topic.
Warning	Alert you any damage that might result form doing or not doing specific actions.
Caution	Give precautionary measures to avoid possible hardware or software problems.
Important	Remind you doing specific actions relevant to the accomplishment of procedures.

Table of Contents

1	System Introduction	1
1.1	Technical Specification	1
1.2	Lamp Specification	2
1.2.1	Lamp for P1165E.....	2
1.2.2	Lamp for P2560E	3
1.3	P1165E/P5260E System Block Diagram	5
2	Firmware Upgraded Flow.....	6
2.1	Setup Tool/Equipment	7
2.2	Upgrading Procedure	7
3	Machine Disassembly and Replacement	11
3.1	Tools.....	11
3.2	Disassembly Procedure	12
3.3	Disassembly Lamp Module	17
3.4	Disassembly the main board and DMD board.....	20
4	Troubleshooting and Verifying the Repair	22
4.1	Troubleshooting.....	22
4.2	Verifying the Repair	28
5	Connector Information	34
5.1	Main Board.....	34
5.2	Ballast Board.....	35
5.3	Power board.....	37
5.4	I/O board.....	38
6	FRU (Field Replaceable Unit) List.....	39
6.1	Mechanical Drawing	40
6.2	Accessory.....	43
6.3	Board/Module	43
6.4	Case/Cover/Bracket Assembly	43
6.5	Optical Device.....	44
6.6	Fans	43
6.7	Miscellaneous.....	44
6.8	Wire	44
6.9	Screws	44
Appendix :	Service mode.....	45

1 System Introduction

1.1 Technical Specification

	P1165E	P5260E
Display Type	0.5 DMD/ 12 ° / LVDS	
Resolution(Pixels)	SVGA(800*600)	XGA (1024 *768)
Lens	Manual Zoom (1.17X) F=2.5~2.74 f=22~25.5mm Screen Size 34 – 307 inches	
Contrast Ratio	2000:1	2000:1
Uniformity	> 54%	
Lamp	Osram E20.6N, 200W	Osram E20.6, 230W
Projection Type	Front, Rear,	
Input Source	D-Sub (15 pin), S-Video, Composite Video, YPbPr, Audio in(Stereo phone jack), USB,	D-Sub (15 pin), S-Video, Composite Video, YPbPr, Audio in(Stereo phone jack), USB, HDMI
Video Compatibility	NTSC 4.43, NTSC-M,PAL-60, PAL-M, N, (B, D, G, H, I), SECAM	
Scanning Frequency		
Horizontal Frequency	15 -80 KHz	
Vertical Frequency	50 – 85 Hz	
Digital Keystone Correction	Vertical + / - 16°	
Integrated Speaker	1(4Ω*2W)	
Noise Level	Less than 35 dBA in Normal mode, or 32 dBA in lamp saver mode	
Environment	Operating: Temperature:+5°C ~ +35°C (41oF–95oF) Humidity:10% ~ 90% Storage: Temperature:-20°C to 60°C Humidity:90% maximum (No condensation)	
Power Requirement	AC 88-264V, 50/60 Hz	
Power Consumption	240W Standby mode: less than 10W	270W Standby mode: less than 10W
Dimension	309 x 229 x 131mm(without elevator foot)	
Weight	< 3 lb	

Note: Designs and specifications are subject to change without prior notice

1.2 Lamp Specification

1.2.1 Lamp for P1165E

Product Type: Short arc mercury lamp with reflector.

The product is a lamp system consisting of a short arc burner within a reflector and an electronic lamp driver.

Type lamp	P-VIP 200/1.0 E20.6n Identcode: A 503 31E
Type driver	PT VIP O3 MID (200W) Identcode: A 493 438

The lamp must be operated with the OSRAM lamp driver only.

Initial Characteristics

Lamp power :	200 W
Measurement :	U sphere
Aperture:	5.0 x 3.8 mm

Radiated Power

UV-output	UVC	248-280 nm	0.01 W typical
	UVB	280-315 nm	TBD
	UVA	315-380 nm	TBD
Total visible flux		380-780 nm	TBD
IR		780-1650 nm	TBD

1.2.2 Lamp for P5260E

Product Type: Short arc mercury lamp with reflector.

The product is a lamp system consisting of a short arc burner within a reflector and an electronic lamp driver.

Type lamp	P-VIP 180-230/1.0 20.6 Identcode: A494 90E
Type driver	PT VIP O3 MID – UNISHAPE Identcode: A516 93D (lock type)

The lamp must be operated with the OSRAM lamp driver only.

Initial Characteristics

Lamp power :	230 W
Measurement :	Integrating sphere
Aperture:	5.0 x 3.8 mm

Power consumption

UV-output	UVC	248-280 nm	0.01 W typical
	UVB	280-315 nm	0.05 W
	UVA	315-380 nm	3 W
Total visible flux		380-780 nm	49 W typical
IR		780-1650 nm	5 W typical

Note: More information about lamp replacement procedure, resetting lamp timer and lamp part number, please check the page 18.

Attention for handling

- ◆ Do not touch the lamp until it has cooled completely, because the lamp is very hot during operation and immediately after turned off.
- ◆ The lamp has to be fixed firmly to the base or socket.
- ◆ Turn off the power supply during maintenance.
- ◆ Do not hold the lamp except outer surface of the reflector.
- ◆ Wear protective gloves and eyeglasses when handling the lamp.
- ◆ Any unusual shock or vibration to the lamp should be avoided.
- ◆ The lamp contains the mercury. Its breakage might cause mercury to flow out of the reflector. Please manage provision at the customer's product.
- ◆ Do not pull the lead wire and plug by more than 24.5N.
- ◆ Please be careful of handling the lamp because it is made of glass.
- ◆ Please notice for keeping or handling the lamp, because there is a projection of this lamp with reflector ahead.
- ◆ Do not touch the bulb and the mirror area of the reflector.

Attention for use

- ◆ Do not close or cover the lamp with any flammable stuff.
- ◆ During operation, the lamp is under extremely high pressure. Please manage provision at the customer's product to prevent fragments of bulb and mercury from flowing out of it. If the lamp bursts in case of an emergency, the sound will be occurred.
- ◆ Lamp operation should be with the specified lamp driver and the system ONLY.
- ◆ Do not look at the lamp directly during operations.
- ◆ Do not expose your skin directly. We recommend to you to put on something for protection for your skin. For example, long sleeve shirt, gloves, glassed and so on.
- ◆ Do not modify the lamp and never use a lamp that has been modified.
- ◆ Any unusual shock or vibration to the lamp should be avoided during operation.
- ◆ Do not use any broken lamps.
- ◆ Dispose of used lamps according to your local instruction.
- ◆ Do not turn on the lamp while the system is opened.
- ◆ The lamp contains mercury. If the lamp bursts during operation ventilate the area sufficiently to avoid inhaling harmful mercury fumes.
- ◆ Use the lead below 200 °C to prevent a deterioration of cladding clad of the fluorocarbon resin.
- ◆ The lead wire insulation clad shouldn't touch the reflector.
- ◆ Exchange the lamp that has already passed the life time immediately.

1.3 P1165E & P5260E System Block Diagram

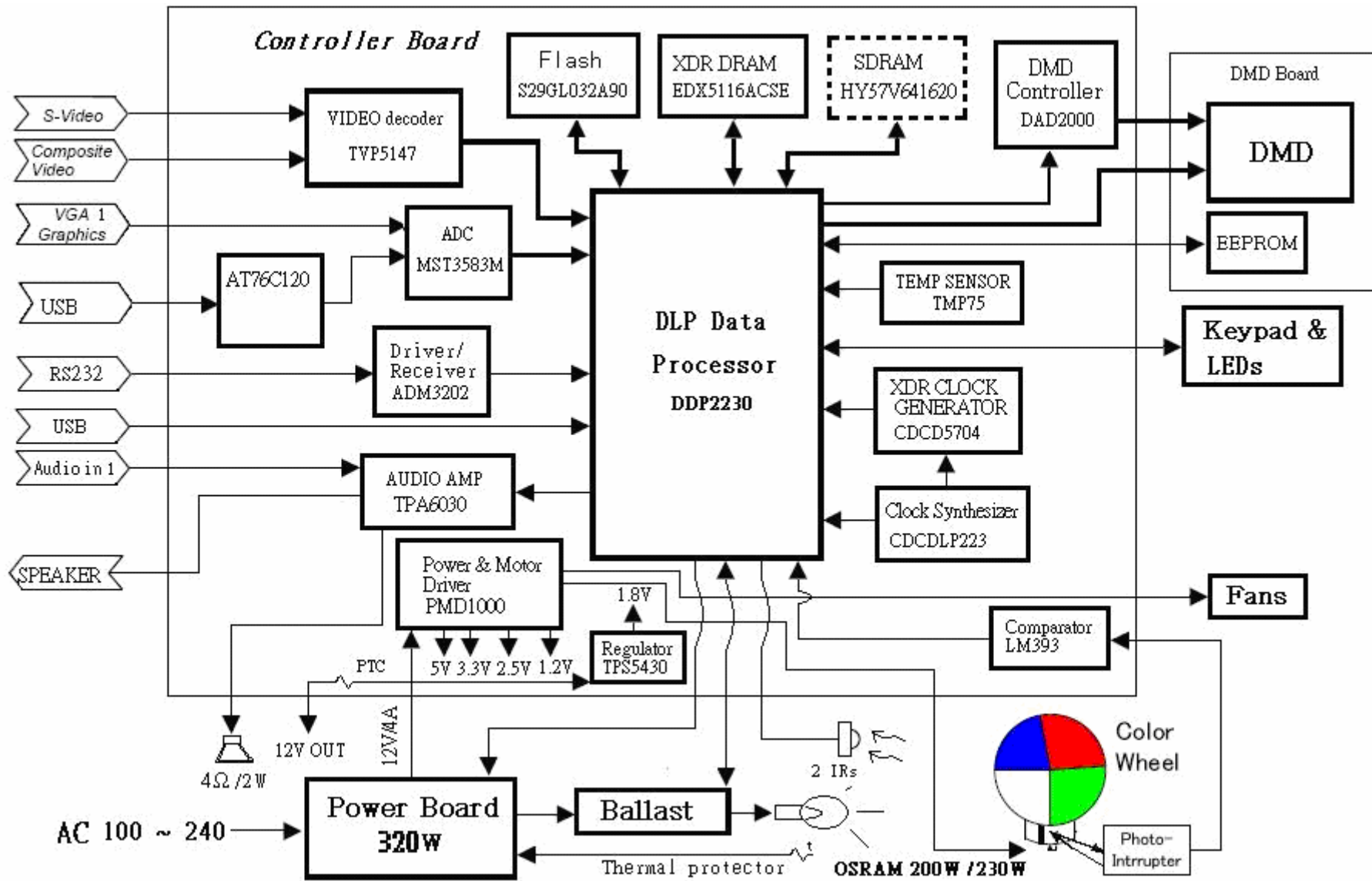

2 Firmware Upgraded Flow

This chapter provides the information regarding relevant equipments and upgrading procedure for firmware upgrade.

Note:

Please check the firmware and composer version before any firmware upgrade procedures. During firmware download period, please do not shut down PC or projector, this will cause flash memory's damage. And need to return the unit to manufacturer for flash memory recovery.

2.1 Setup Tool/Equipment

- Computer
- USB Cable (See the picture)
- Power Cord



2.2 Upgrading Procedure

Installing [DLP Composer (TM) Lite]

1. Double-click [DLP Composer Lite v7.1 Setup.exe].
2. Installation starts. Click [Next] to continue the installation process.
3. On the [License Agreement] screen, move the scroll bar on the right to the bottom, select [I accept and agree to be bound by all the terms and conditions of this License Agreement], and click Next to continue the installation process.
4. On the Select [Installation Type] screen, select [ALL] and click [Next] to continue the installation process.



5. When the installation is finished, click [Finish] and reboot the PC. (A shortcut to DLP Composer (TM) Lite is created on the desktop.) **Note: Please notice the version is 7.1 not 6.0.**



USB Support - Installation (All Platforms)

This release includes support for a USB communications interface to DDP2230-based projectors. The setup program includes the files needed to install USB support (for Windows 98/Me/2000/XP only – Win95, WinNT and Windows Vista are not supported). After DLP Composer™ Lite is installed, to install the USB support, choose the "Install DDP2230 USB Driver" icon under "DLP Composer™ Lite" in your Start menu. **Note: The version is 7.1 not 6.0**



Follow the instruction on the screen to press any key and wait for the installation done.

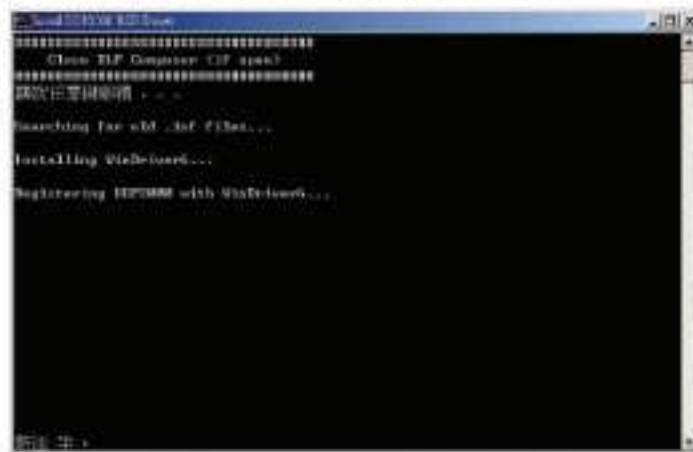

Operating procedure

1. Connect the Projector and PC via USB cable.
2. Double-click **[DLP Composer (TM) Lite]**. The following screen will appear.



3. Select **[Edit]/[Preferences]/[Communications]** to check **USB** in **[Projector Interface]**.

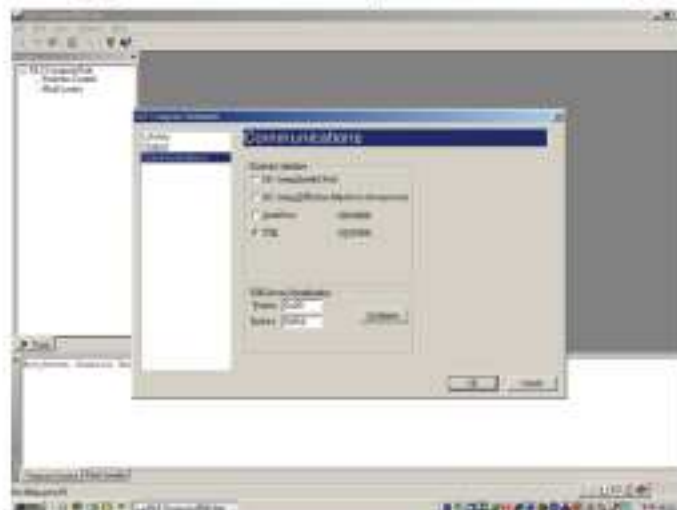

4. Click **[USB Device Identification]**.
5. Set the items on the **[Vendor 0x451, Product 0x2000]**.
6. Click **[OK]**
7. Move the cursor to **[Flash Loader]** on the Project window of **[DLP Composer Lite]**. (The **[Flash Loader]** screen will appear.)
8. Click **[Browse]** and select where the firmware **[xxxxxxx.img]** is for download.
9. Make sure **[Skip Boot Loader Area]** is with a check.
10. Press Menu and Power buttons constantly and then give power supply (switch power on). Power LED and Lamp LED will become amber. That indicates the projector is in the download mode. At this moment, you can release these two buttons.
11. Click **[Start Download]**. When the dialog box is displayed, click **[Yes]**.

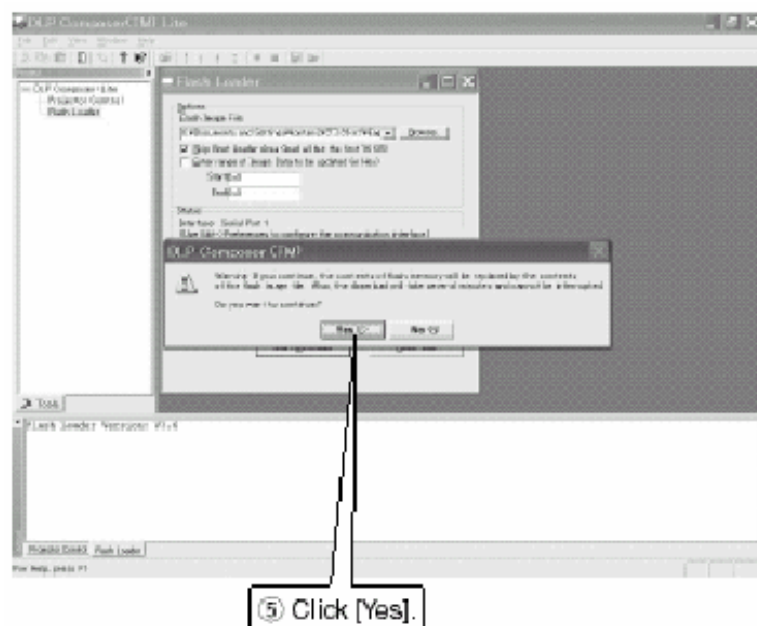
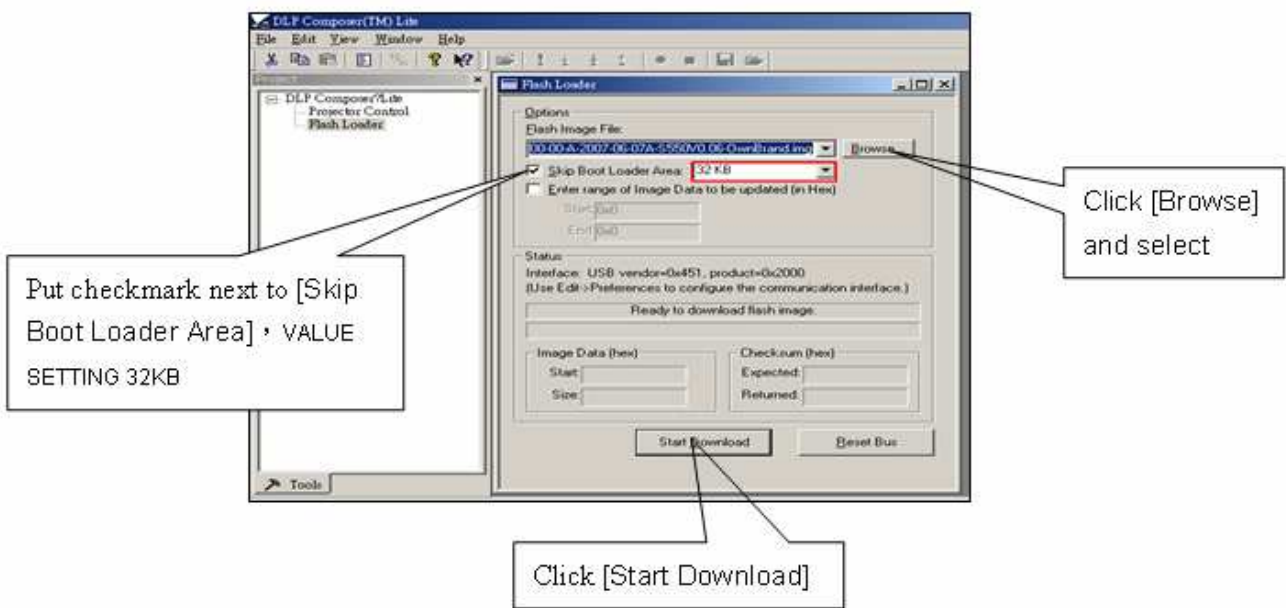





12. Wait for the Completion of Burning and then remove Power Cord and Burning Cord

Note: In case, the device manager can't recognize the DDP2230 as blow, please disable this device. This will not affect upgrade procedure.

3 Machine Disassembly and Replacement

3.1 Tools

Item	Photo
Long Nose Nipper	
Hex Sleeves 5mm	
Screw Bit(+):107 Screw Bit(+):101 Screw Bit(+):102	
Anti-static wrist strap	
Anti-static wrist gloves	

3.2 Disassembly Procedure

Warning

- ◆ Put on the Static Electricity Ring when starting for repair.
- ◆ Repair Environment suggest in Clean-room class 10000. Do not remove Optical Engine or DMD panel outside the clean room. Please return the optical engine to supplier if your repair condition can not meet the requirement.
- ◆ While screwing or unscrewing screws, please keep the screwdriver straight. Keeping screwdriver inclined will damage the screw holes.
- ◆ Please turn off the power before replacing any parts.
- ◆ Please wait for the projector lamp cooling down and turn off the power before changing it. Never touch or hit the lamp module when replacing the lamp.
- ◆ When you replace the projector lamp, never touch the new lamp with your bare hands. The invisible residue left by the oil on your hands may shorten the lamp life. Use lint-free gloves or finger cots are recommended.

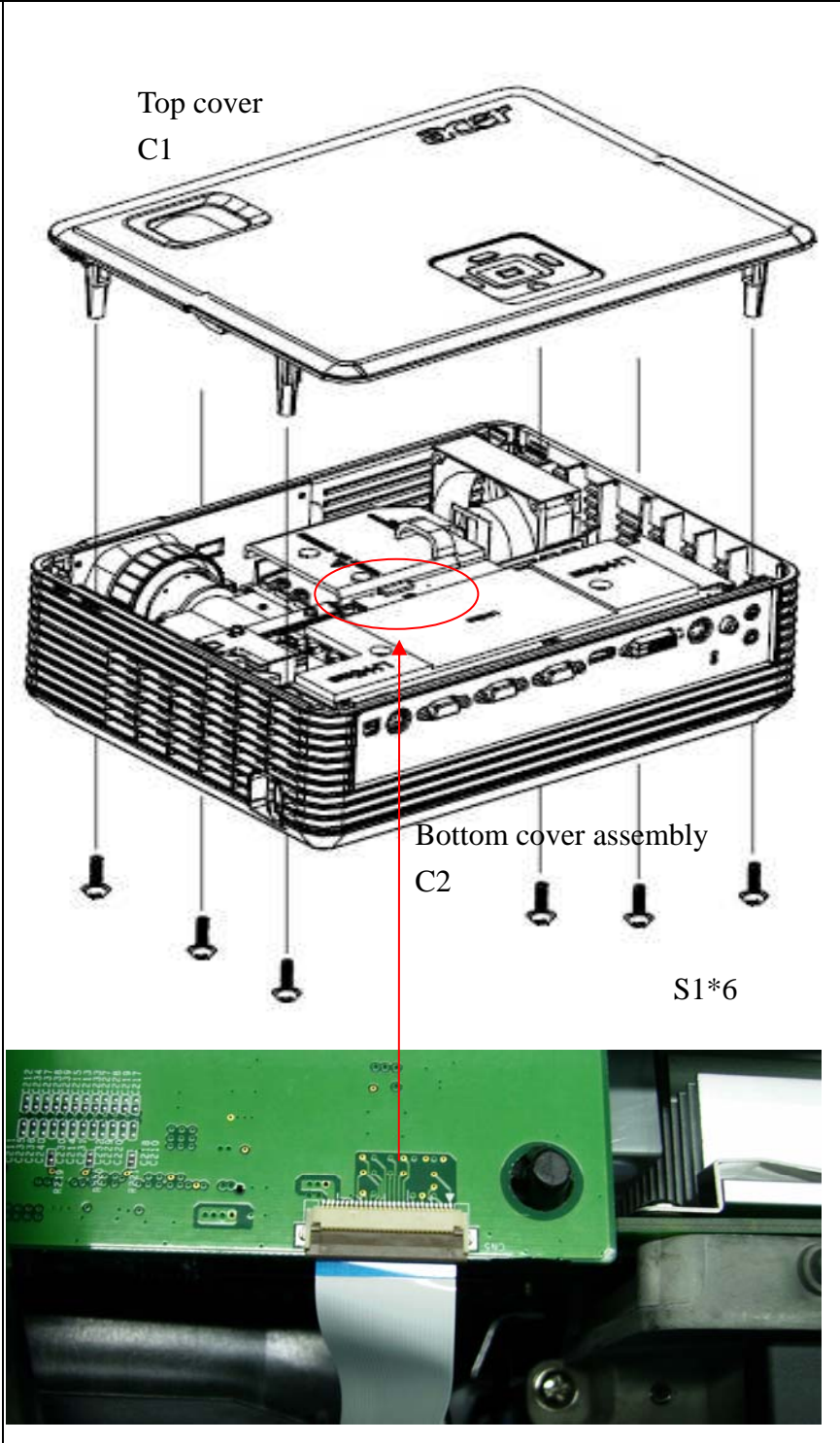
Step	Figure	Description
1	 <p>Top cover C1</p> <p>Bottom cover assembly C2</p> <p>S1*6</p>	<p>Preparation: Press the power button to shutdown the projector and disconnect the power cord.</p> <p>Flip the projector and remove the screws (6ea) as the photo showing, then turn over the projector to take off the top cover.</p> <p>Note: 1. If the lamp is hot, please do not start any procedure until the lamp cools down. 2. If you feel the top cover is hard to take off, try to open the lamp cover first then take the cover off.</p> <p>How to open the lamp cover? Refer to 3.3 Disassembly Lamp Module.</p> <p>3. When taking off the top cover, take care of the flex wire. Disconnect the wire first (as the photo showing).</p>

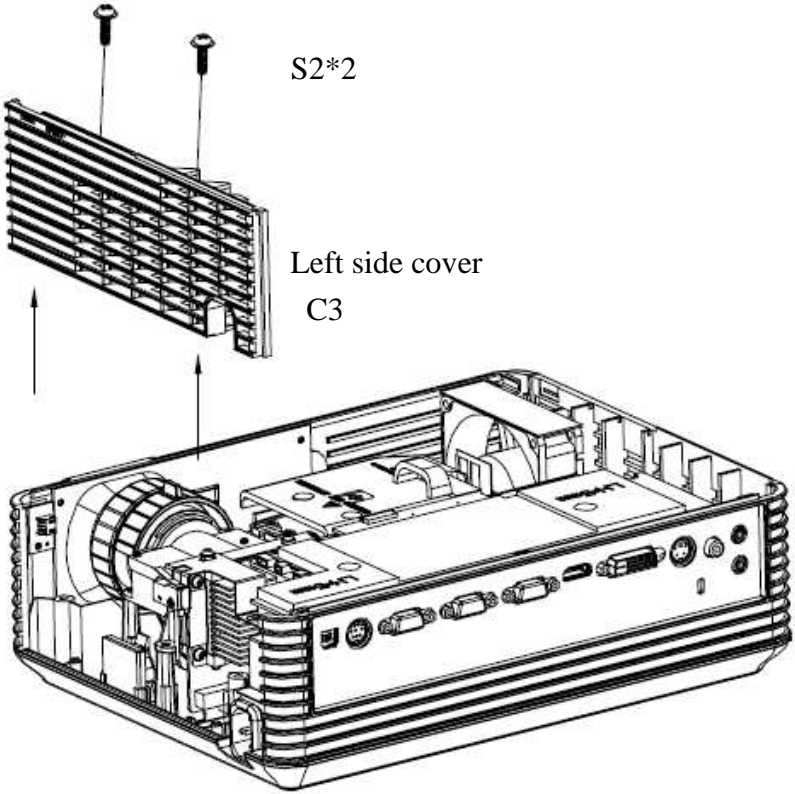
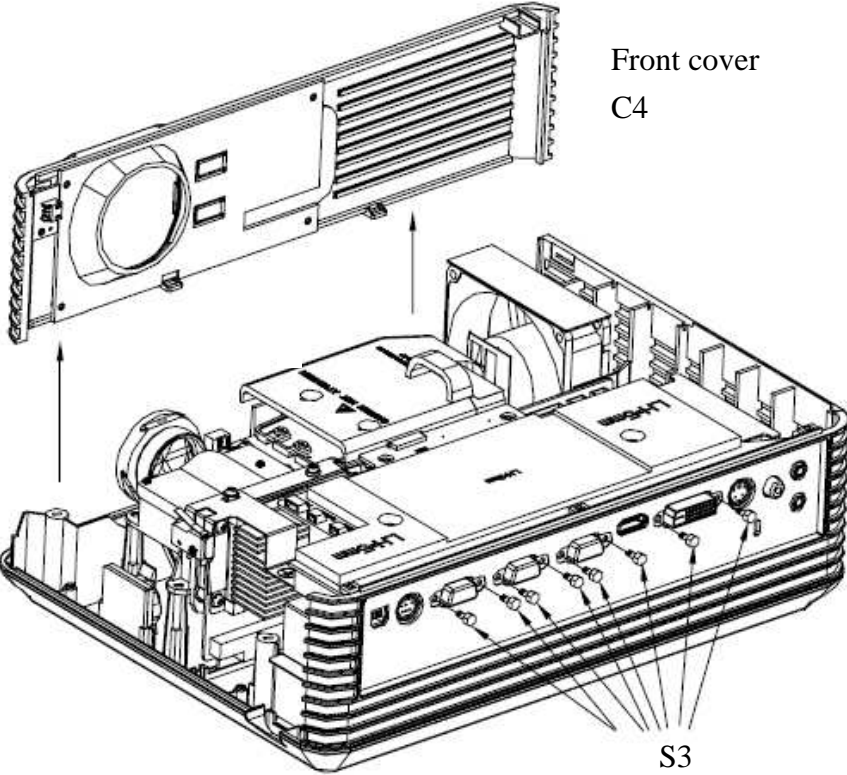

Step	Figure	Description
2	 <p>S2*2</p> <p>Left side cover C3</p>	<p>Loosen the screws (2ea) as shown to disassemble the side cover.</p>
3	 <p>Front cover C4</p> <p>S3</p>	<p>Pull the front cover up to disassemble it (as photo showing). Then loosen the screws of the I/O board on back cover as shown.</p> <p>Note: there are 8ea screws for P5260E but 6ea for P1166, because of one more VGA connector.</p>

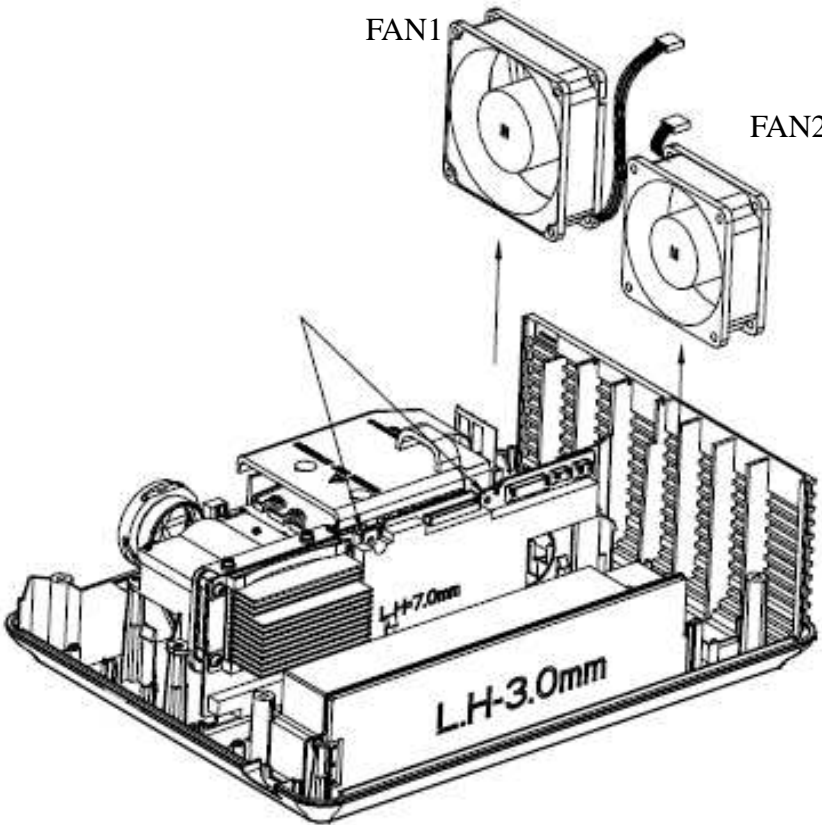
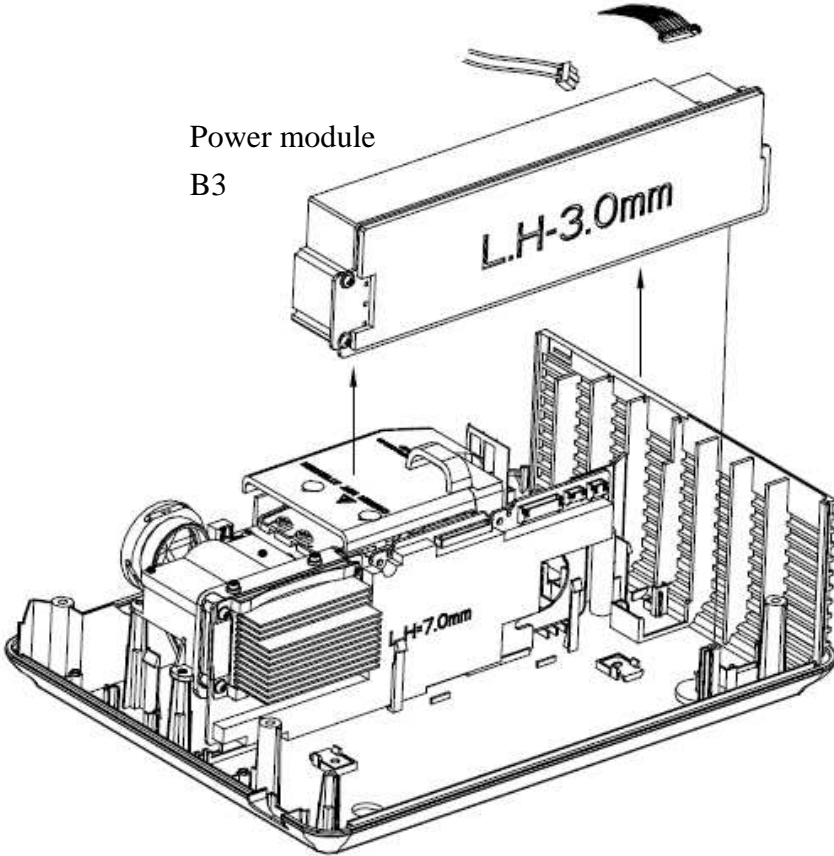
Step	Figure	Description
4	<p style="text-align: center;">S4*2</p> <p>I/O Board B1</p> <p>Back cover C6</p> <p>I/O name plate C7</p> <p>S2*1</p> <p>LH-3.0mm</p>	<p>Loosen the screws of the I/O board (as photo shown) then take off the board and back cover.</p> <p>Note: before removing the boards, make sure the wires are all disconnecting. Or you may destroy the wire or connector.</p>
5	<p>S5*1 S2*2</p> <p>S4*1</p> <p>Ballast B2</p> <p>LH-7.0mm</p> <p>LH-3.0mm</p>	<p>Remove the ballast module.</p> <p>As photo showing, loosen the screws (3ea for the metal dome and 1ea for the ground wire), then take off the module.</p> <p>Note: the metal has a hook for tightening the module, be careful when taking it off.</p>

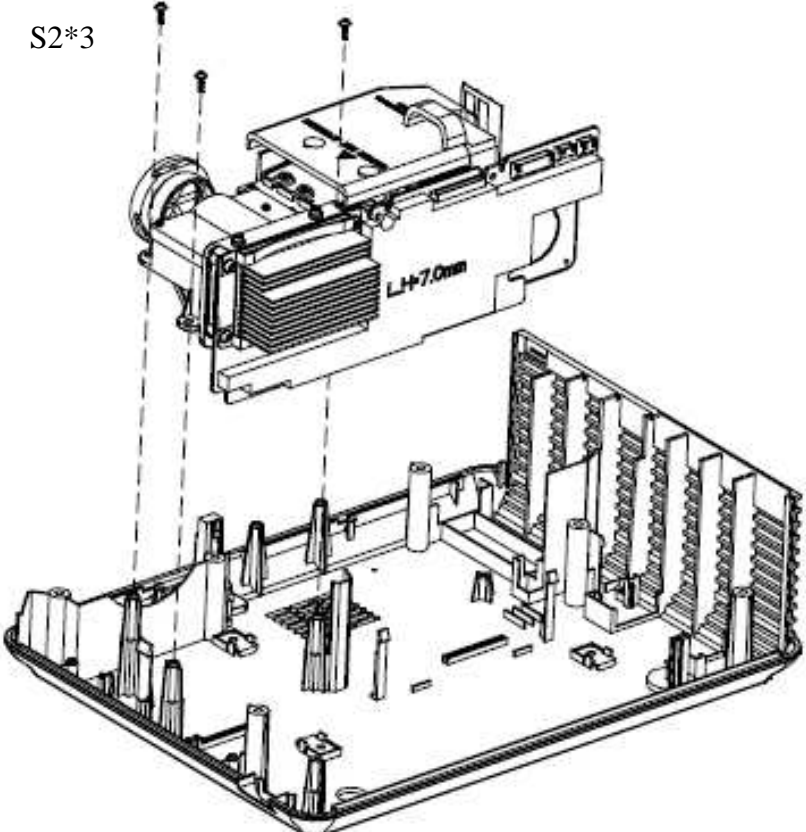
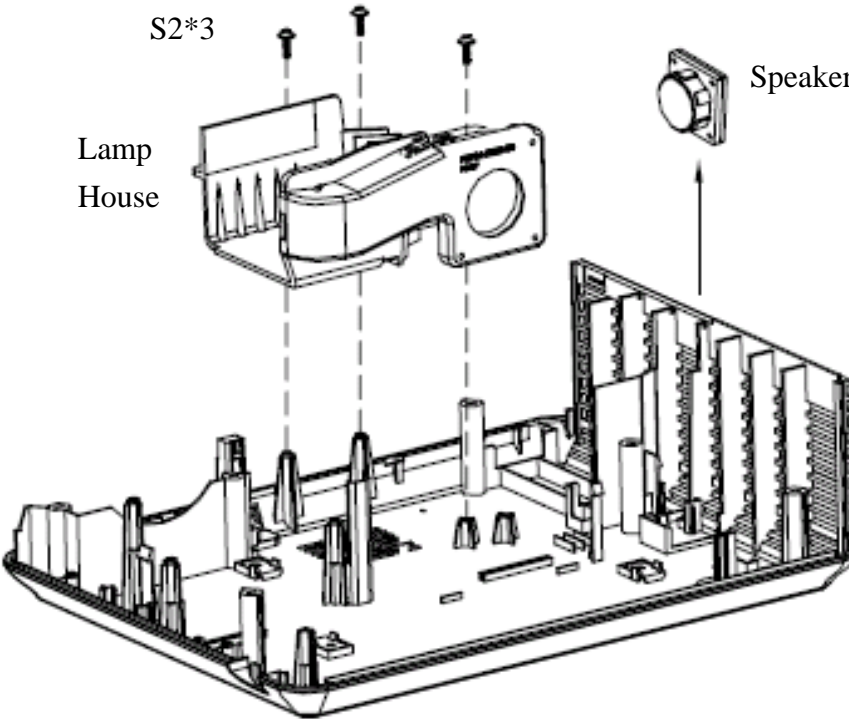
Step	Figure	Description
6	 <p>FAN1</p> <p>FAN2</p> <p>L.H-7.0mm</p> <p>L.H-3.0mm</p>	<p>Disconnect the connectors of the fans, then pull off the fans as the direction as the photo showing.</p>
7	 <p>Power module B3</p> <p>L.H-3.0mm</p> <p>L.H-7.0mm</p>	<p>Disconnect the wires then pull the power module out.</p> <p>Note: there is no screw for the module.</p>

Step	Figure	Description
8	 <p>S2*3</p>	<p>Remove the screws as showing and take off the optical engine.</p>
9	 <p>S2*3</p> <p>Lamp House</p> <p>Speaker</p>	<p>Loosen the screws and take off the lamp house. Take off the speaker.</p>

3.3 Disassembly Lamp Module

Step	Figure	Description
1		<ul style="list-style-type: none"> ● Turn off the projector. ● Unplug the power cord. ● Open the lamp cover as the photo showing (Push the switch on "OPEN" to unlock the lamp cover, then push the lamp cover as the direction the arrow showing. Uncover the lamp cover then you open the cover.)
2		<ul style="list-style-type: none"> ● Loosen the two screws of lamp module

3

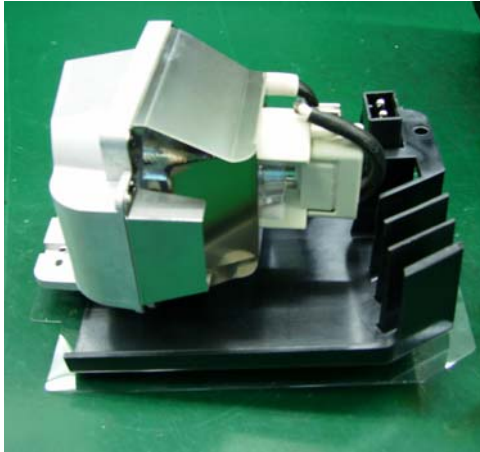

- Pull the lamp module out by lamp handle.
- Insert the new lamp module into the projector and tighten the screws.
- Replace the lamp cover and tighten the screws.
- Reset the lamp timer. Press **MENU**, go to **Setup > Advanced setup > Reset lamp hours**, and press **MENU**.

Note: Turn on the projector. If the lamp does not turn on after the warm-up period, please reinstall the lamp.

3.4 Disassembly the main board and DMD board

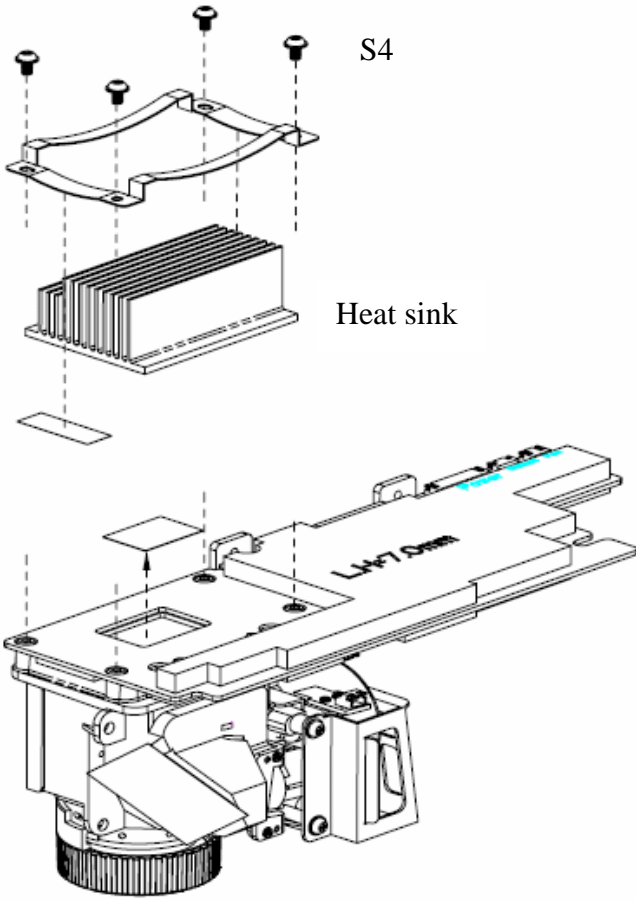
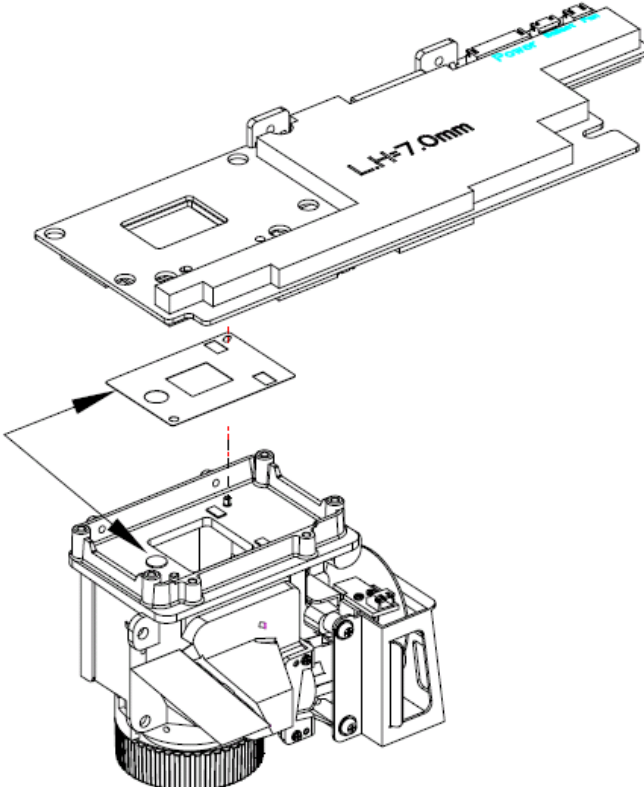
Step	Figure	Description
1		<p>Prepare the optical engine disassembled just now.</p> <ul style="list-style-type: none"> ● Remove the screws*4 ● Take the heat sink off. ● Take off the PCB pad and thermal pad carefully. <p>Note: Remember the assembling direction of the heat sink. It will help you when you assemble the main board again.</p>
2		<ul style="list-style-type: none"> ● Take the main board off. ● Take off the DMD aperture. <p>Note: Take attention to the shape of DMD aperture holes.</p>

3

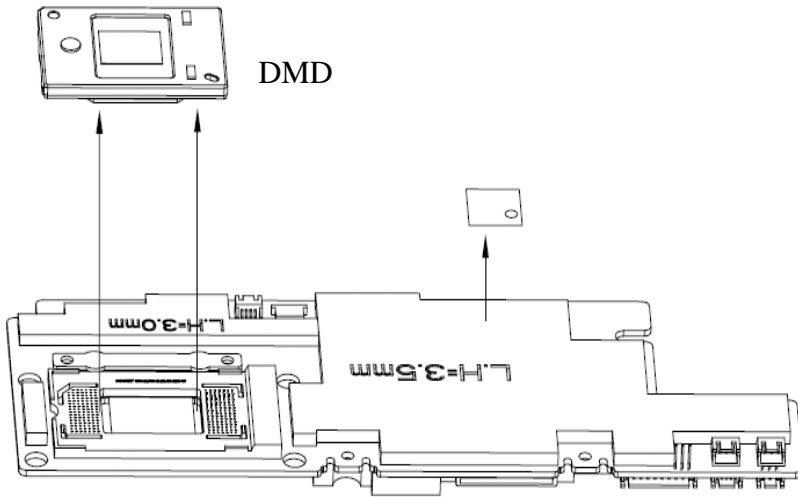

DMD

- Take off the DMD.

Warning: If there is exactly need to disassemble the main board or DMD, doing this in a workshop with a higher air grade than 1000 is strongly suggested.

4 Troubleshooting and Verifying the Repair

This chapter provides technicians with electronic background how to maintain the product. Moreover, you can get the appropriate operation to solve some complicated problems of component repairing and professional problems.



4.1 Troubleshooting

Warning

- Do not directly look into the lens to avoid eyesight damages.
- The projector is equipped with ventilation holes (intake) and ventilation holes (exhaust). Do not block or place anything near these slots, or internal heat build-up may occur, causing picture degradation or damage to the projector.

Confirm Software and hardware

- (1) Confirm FW version and lamp using hours(version and lamp hours in the help menu)
- (2) Confirm LED indicator

State/ Problems	Icon/ Messages	Close Messages	LED Indicators	
			TEMP	LAMP
Environment overheat			On	
Fan lock				
System error			F2	F2
Lamp life time	The lamp life is ending.	Press any key		
Lamp error				On

F2: Flash 2Hz

- (3) Confirm cable connection well.
- (4) Confirm Main-board version

Note: Swapping modules that may be defective with others known to be good is generally an ideal way to find the module responsible for the problem. A failure symptom is rarely caused by more than one module, so you will not usually need to replace more than one to correct a particular failure. Whatever main board, ballast, IR board, power board, lamp module or optical engine are all suitable to check by swapping modules.

Power Source Troubleshooting:

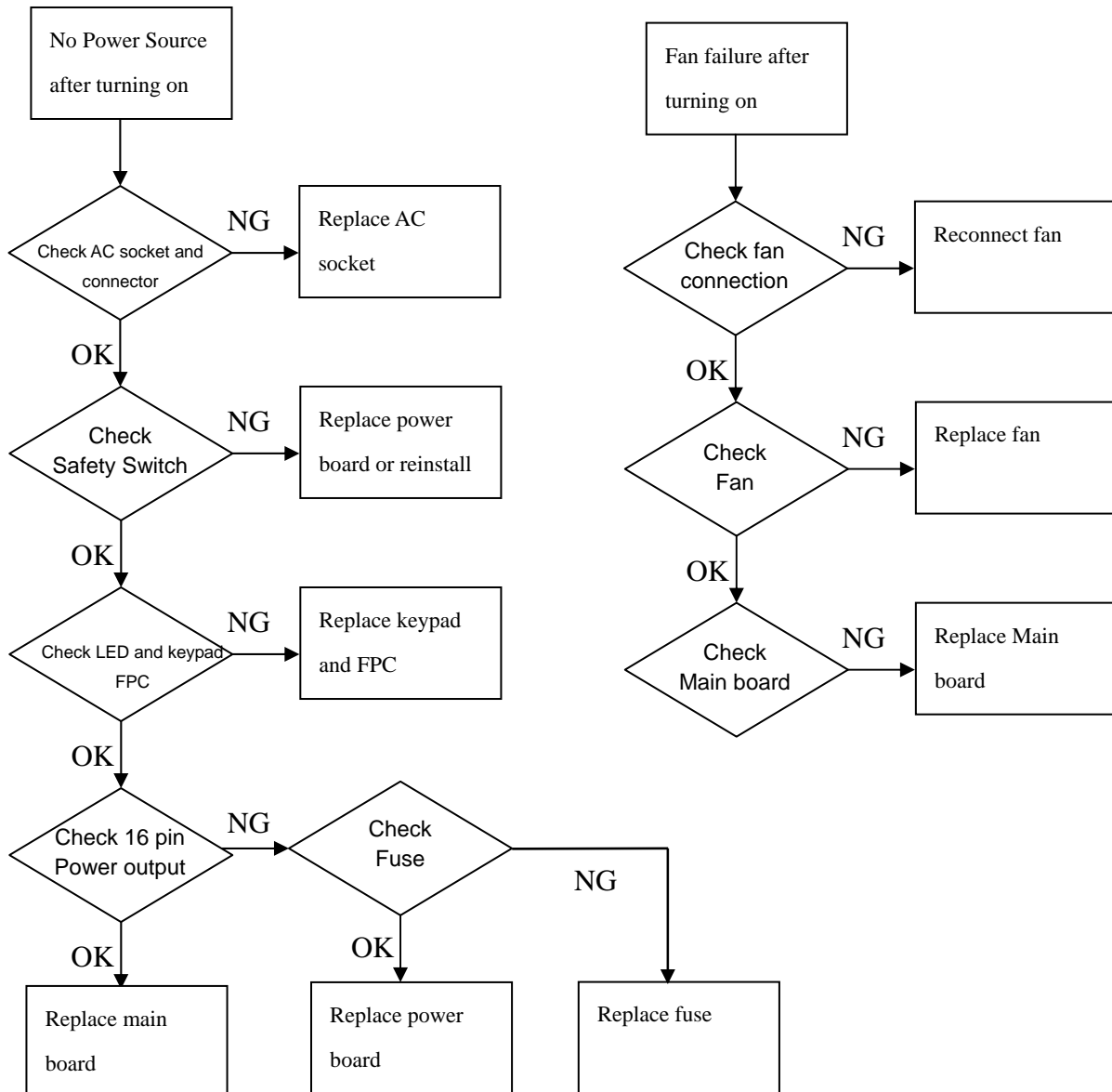

How to check the power board?

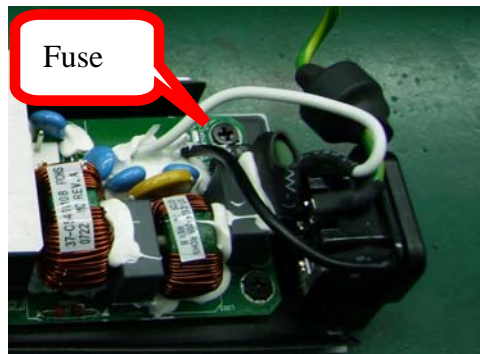
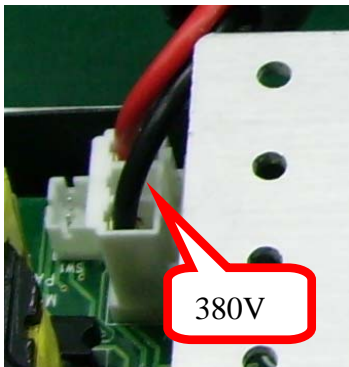

- check the 380v output on connector 3 (see ballast board page 35)
- check the fuse on the power board

Light and Sound Troubleshooting

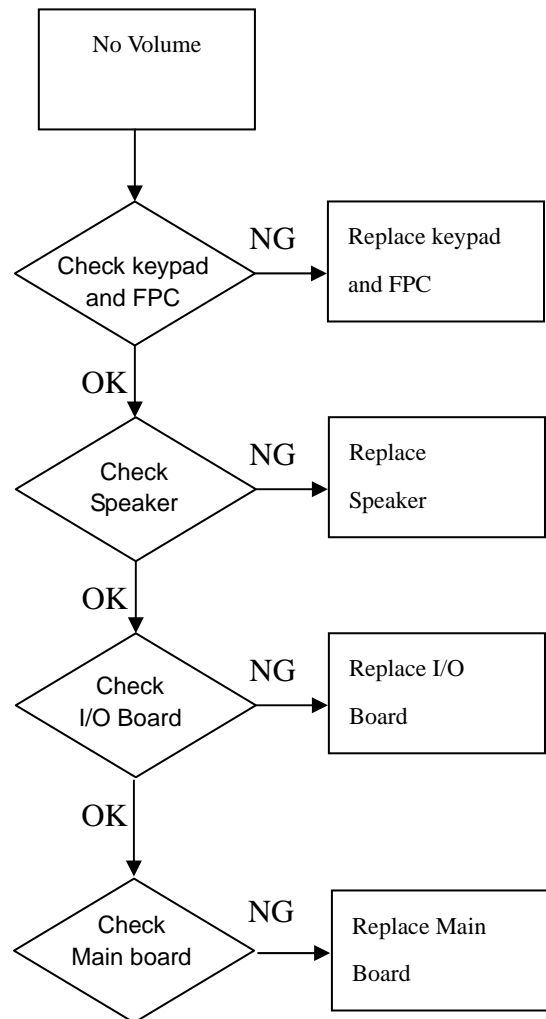
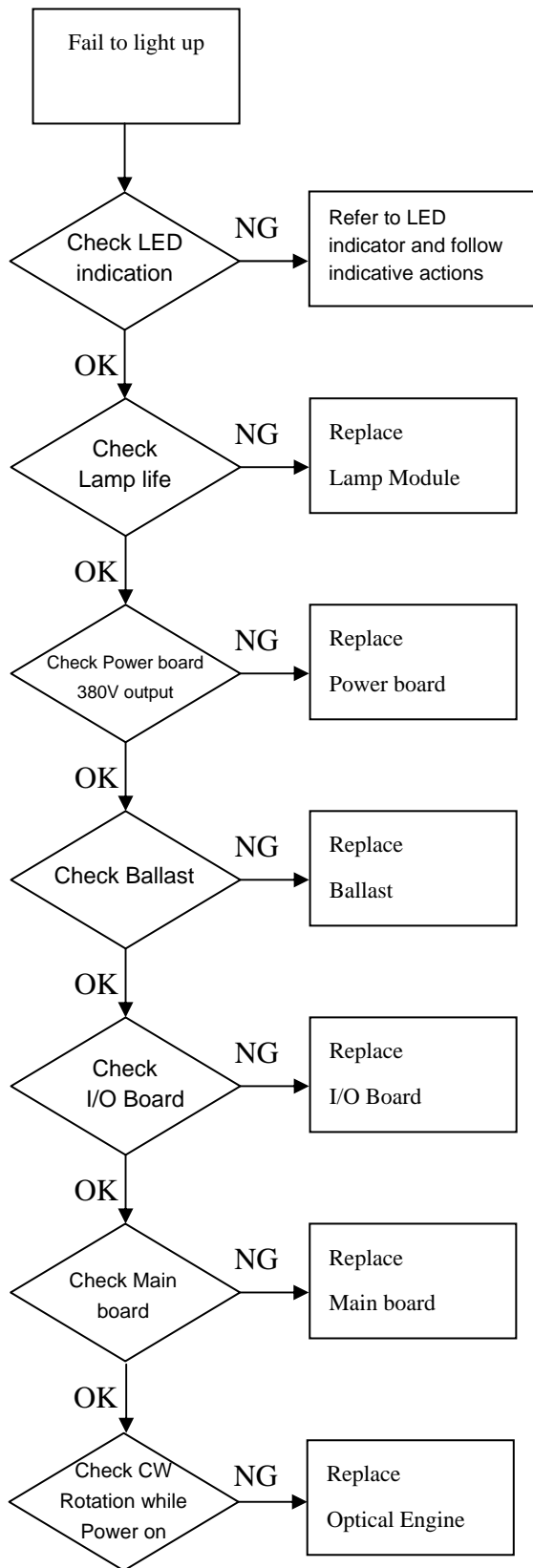

Video Signal Troubleshooting

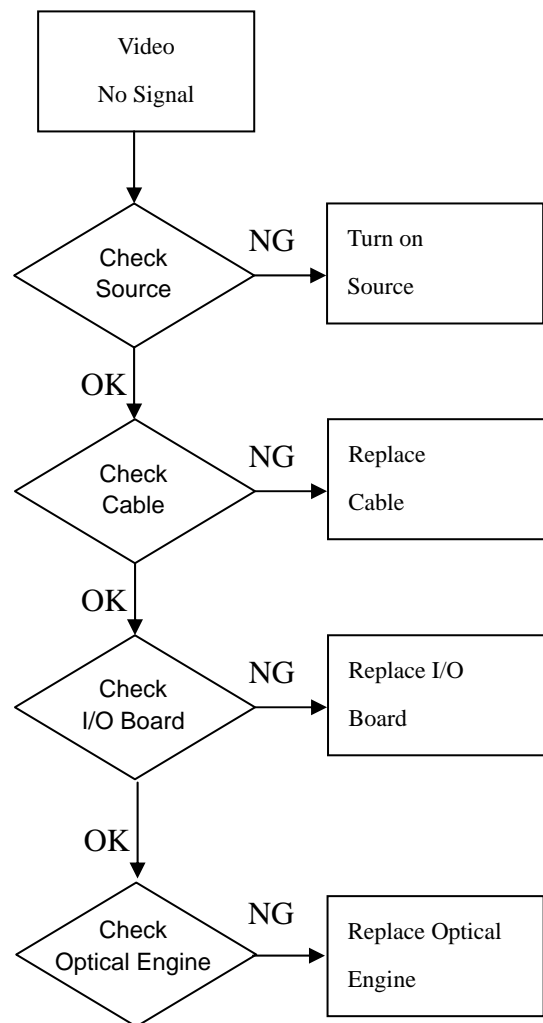
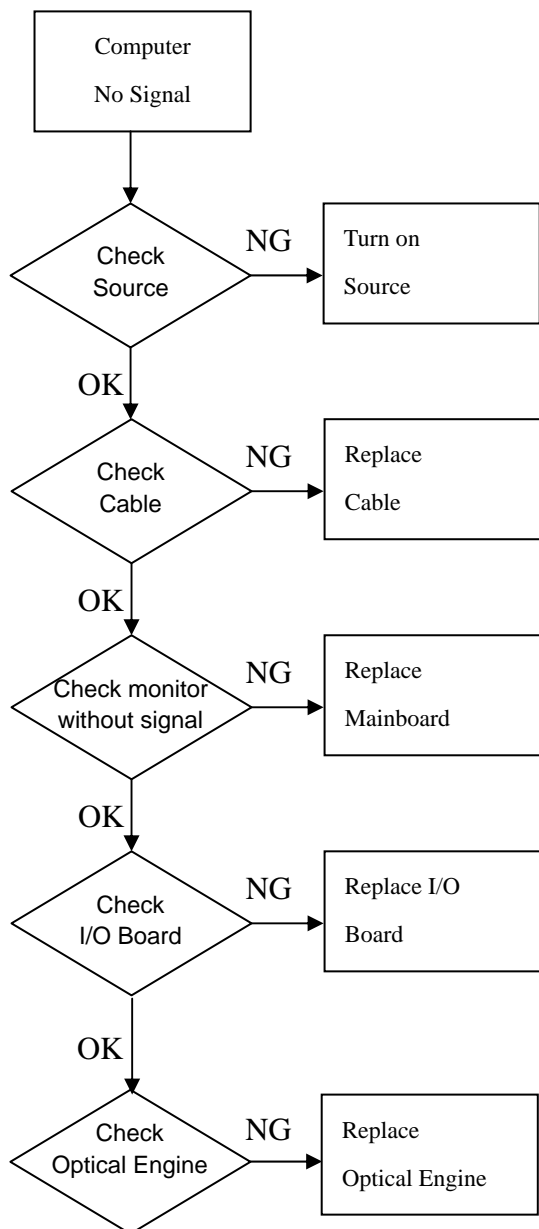

Abnormal Image Troubleshooting

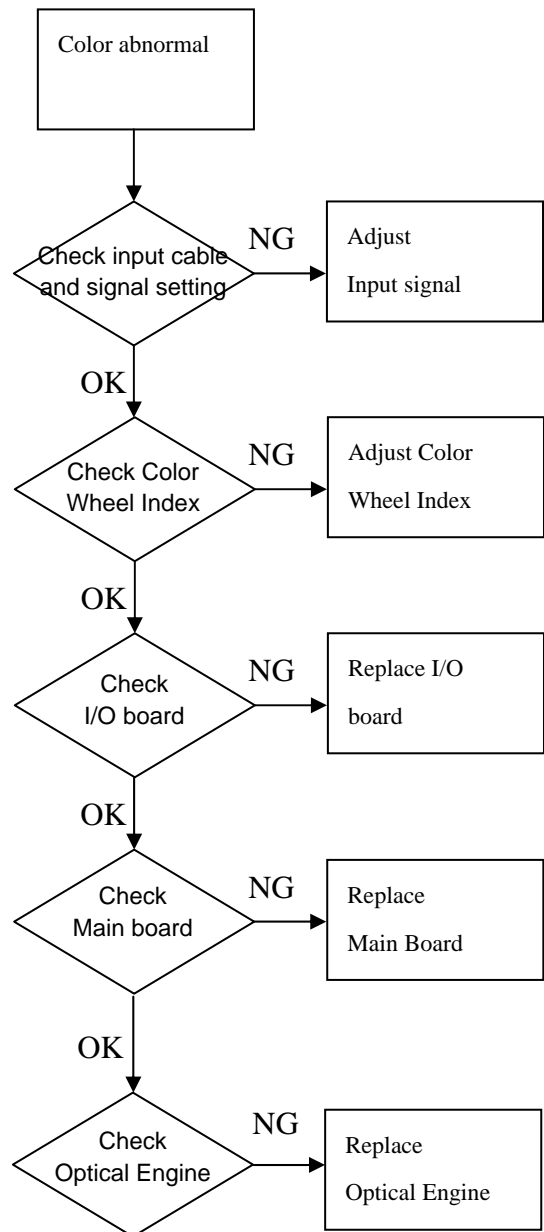
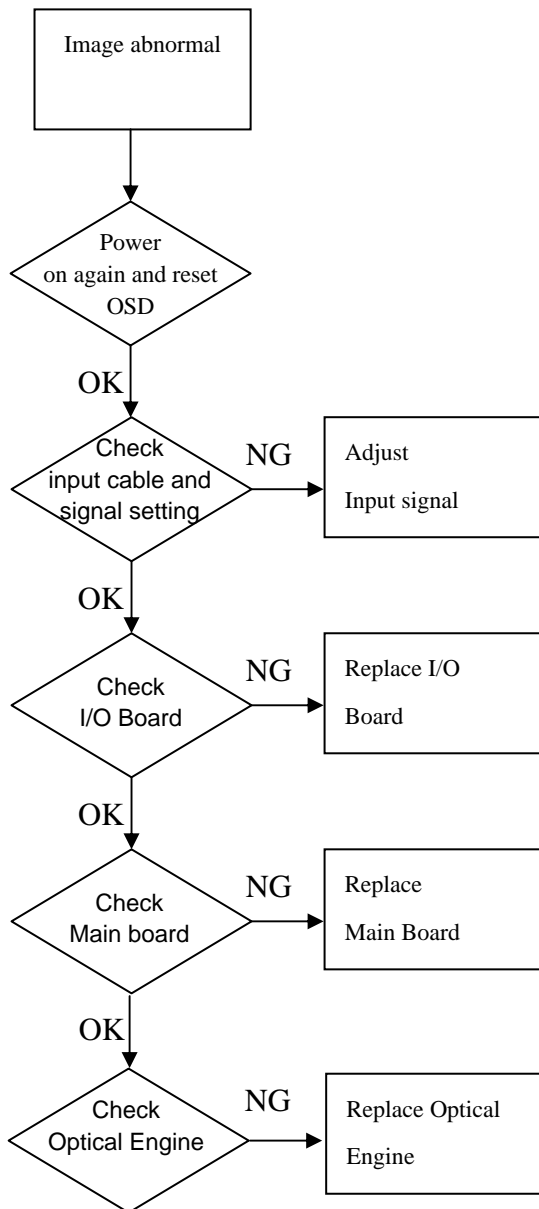

Operation Function Troubleshooting

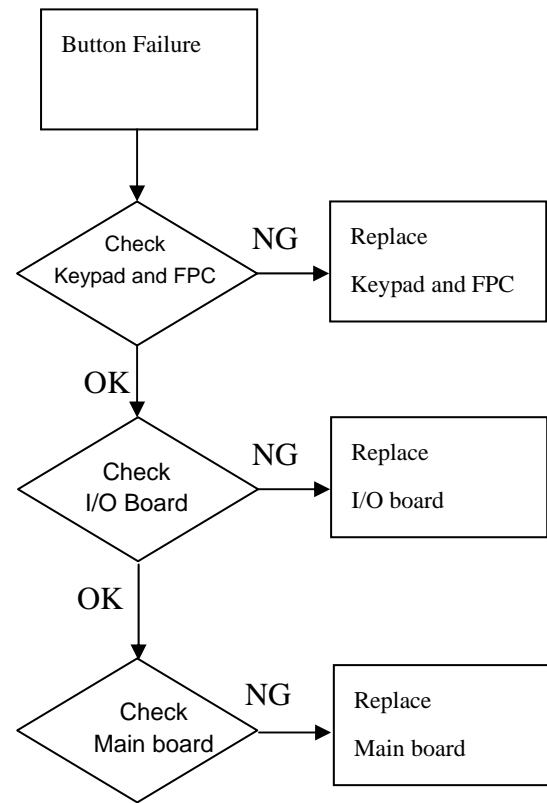
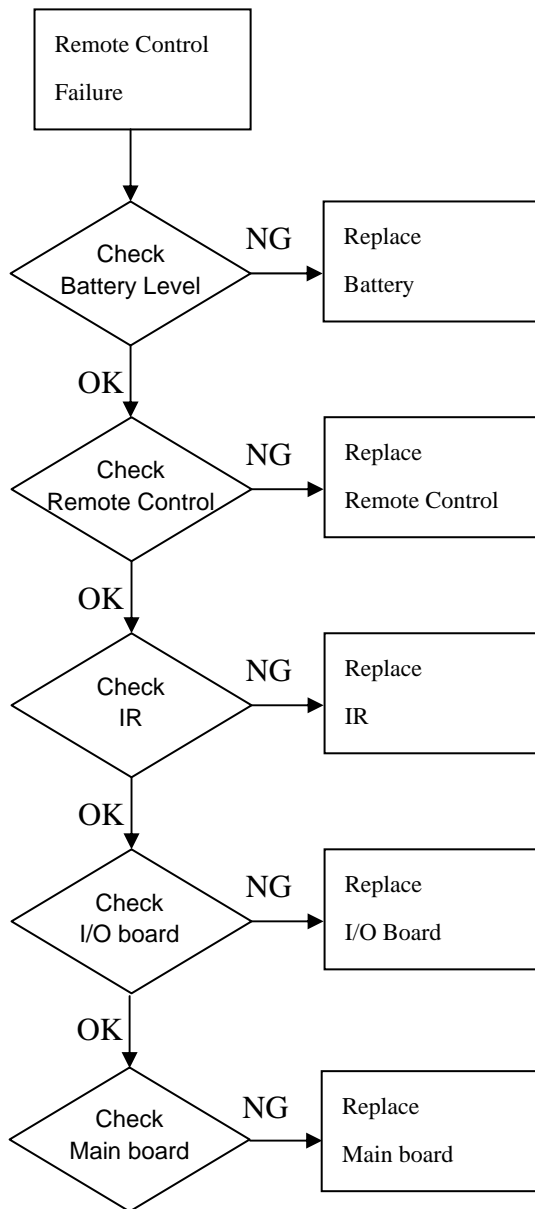

4.2 Verifying the Repair

After repairing projector (Disassembling and assembling projector), Repair center should verify the quality of repaired unit.

(1) Signal test (Each I/O can function normally)

Connect all connector to the jacks one after another to check whether each channel can project normally

I/O port	Monitor In (VGA)
Test Equipment	Standard Pattern generator (Ex. Quantum data)
Signal format	1024*768 60Hz (800*600 for P1166)

I/O port	Video
Test Equipment	Standard Pattern generator (Ex. Quantum data) or DVD player
Signal format	NTSC

I/O port	S-Video
Test Equipment	Standard Pattern generator or DVD player
Signal format	480i

I/O port	USB
Test Equipment	PC and Remote controller
Test method	<ol style="list-style-type: none">1. Connect PC (laptop) VGA output to projector. Set PC (laptop) output signal to projector2. Connect projector USB to PC. Press remote controller page up/down to scroll presentation file up and down (ex Microsoft office series)

I/O port	Audio input
Test Equipment	Connect audio input to audio output of DVD player
Signal format	480i

(2) Operation test

Buttons operation

Button description	Test criteria
Power button	1. Mechanical motion (Up & Down) should be free from getting stuck when pressing the button 2. Press "power" button and projector will switch on
Menu/Enter	1. Mechanical motion (Up & Down) should be free from getting stuck when pressing the button. 2. Press Menu/Enter button can make projector function normally.
4-way button (Keystone/Auto/Source)	1. Mechanical motion (Up & Down) should be free from getting stuck when pressing the 4-way button. 2. Press Menu/Enter button can make projector function normally.

Foot adjuster operation

Foot adjuster.	Test criteria
Foot adjuster button	Foot adjusters should stretch downward smoothly by pressing the foot adjuster buttons on the two sides

Zoom ring and Focus ring

Ring	Test criteria
Zoom ring	Mechanical motion of rotating Zoom ring to the end of right and left by hand should be free from getting stuck.
Focus ring	The feeling of rotating Focus ring to the end of right and left by hand should free from seizing

(3) Image Quality



Projected image size: 60 inches (diagonal length)

Zoom ring: Adjust zoom ring to wide (Maximum projection size)

VGA

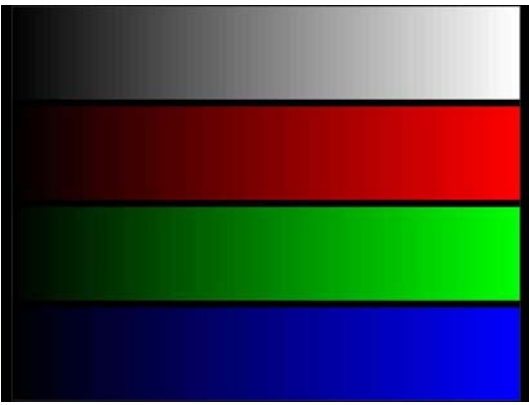
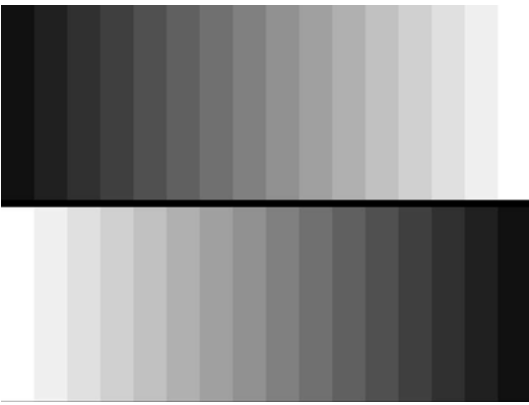
I/O port	Monitor In (VGA)
Test Equipment	Standard Pattern generator (Ex. Quantum data)
Signal format	1024*768 60Hz (800*600 for P1166)
Projected image size	60" in diagonal length

Test Pattern	Test criteria
	<p>Full white</p> <p>Apparent color strip, bend and streak corner on the projected image are not allowable</p>
	<p>256 level RGB</p> <p>--256 level of RGB color should be distinguishable, at least Red color scales should be.</p> <p>-- For each RGB 256 levels, Noise or color deviation in R, G, and B single level respectively are acceptable.</p>
	<p>16 gray level</p> <p>--16 level of gray level color should be distinguishable</p> <p>--When Gamma selected to "RGB"</p> <p>Not distinguishable of 2 brightest levels /2 darkest levels are acceptable.</p>

	<p>Gray 10 Blemish, stain are not allowable on the projected screen</p>
	<p>Full darkness Light leak in the non-effective area. Should be less than 0.7 lux(<0.7lux)</p>

S-Video

I/O port	S-Video
Test Equipment	Standard Pattern generator (Ex. Quantum data)&DVD player
Signal format	480i
Criteria	No apparent color deviation on the projected image

Video

I/O port	Video
Test Equipment	Standard Pattern generator (Ex. Quantum data)&DVD player
Criteria	No apparent color deviation on the projected image

(4) Resolution

I/O port	VGA
Test Equipment	PC
Test Method	<ol style="list-style-type: none"> 1. Rotate Zoom ring to wide mode (Maximum projected image) 2. Fix projector to set diagonal length of projected image to 60". 3. Adjust focus ring to make resolution of 4 corners and center are balanced. 4. Check he characters should be recognized easily. 5. Rotate Zoom ring to tele mode (Minimum projected image) 6. Adjust focus ring to make resolution of 4 corners and center are balanced. 7. Check the characters should be recognized easily.

(5) Front and Rear infrared sensor

Device	Front and Rear infrared
Test Equipment	Remote controller
Test method	<ol style="list-style-type: none"> 1. Cover front sensor and operate remote controller to test rear sensor 2. Cover rear sensor and operate remote controller to test front sensor

(6) Brightness measurements

Test items	Brightness measurements
Test Equipment	Chroma automatic system (The alternative is CL-200)
Test method	Measure 9 points
Criteria	Marketing spec 20% off

(7) Safety test equipments

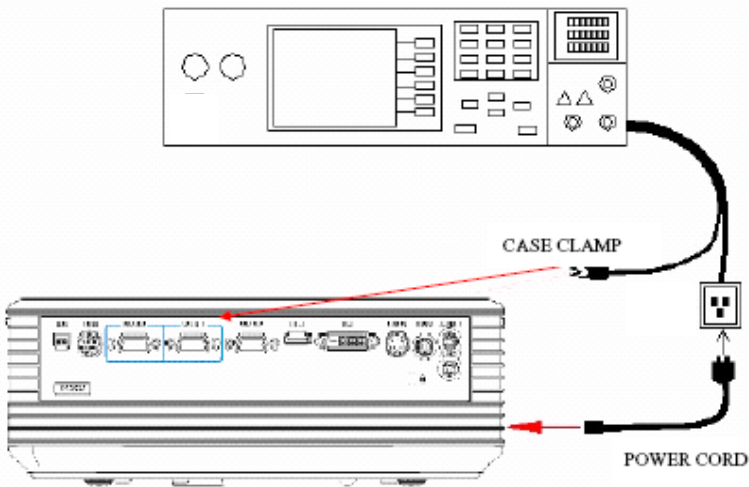
Test items	Safety test
Test Equipment	Safety analyzer
Test method	<ol style="list-style-type: none"> 1. Clamp the metal shell of VGA connector 2. Plug the power cord to socket 
Test criteria	<p>GND 30A 3sec 100mΩ DCW 2506V 1sec 250uA Single Step OFF</p>

(8) Cosmetic standard for repaired projector

Follow cosmetic standard of repair center.

5 Connector Information

This section provides each connector location on boards and function of each board. They will be useful for your detecting the defective boards.

5.1 Main Board

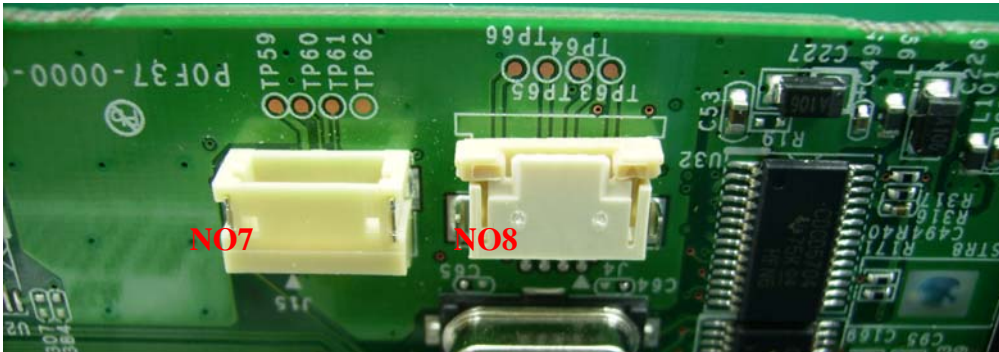
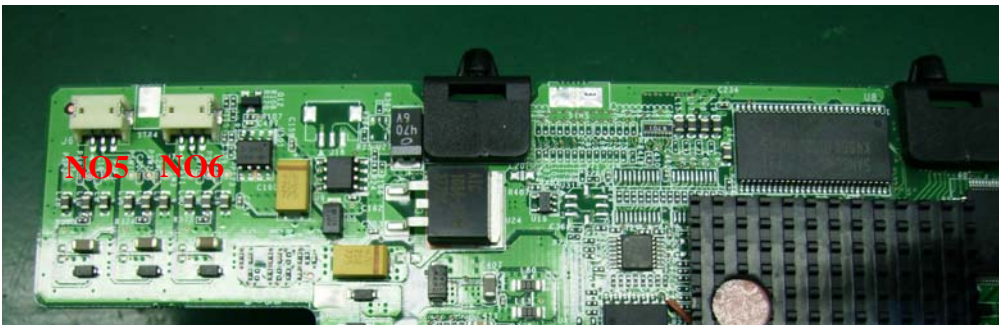

Connector	Description
No 1	Connect to I/O board
No 2	Power supply
No 3	Ballast control
No 4	Fan2
No 5	Fan1
No 6	Fan3
No 7	C/W sensor
No 8	Color wheel control

5.2 Ballast Board

BALLAST FOR P1165E

Tc1 switch point (NTC SMD resistor at bottom side of pcb) : tbd°C +/- 5°C

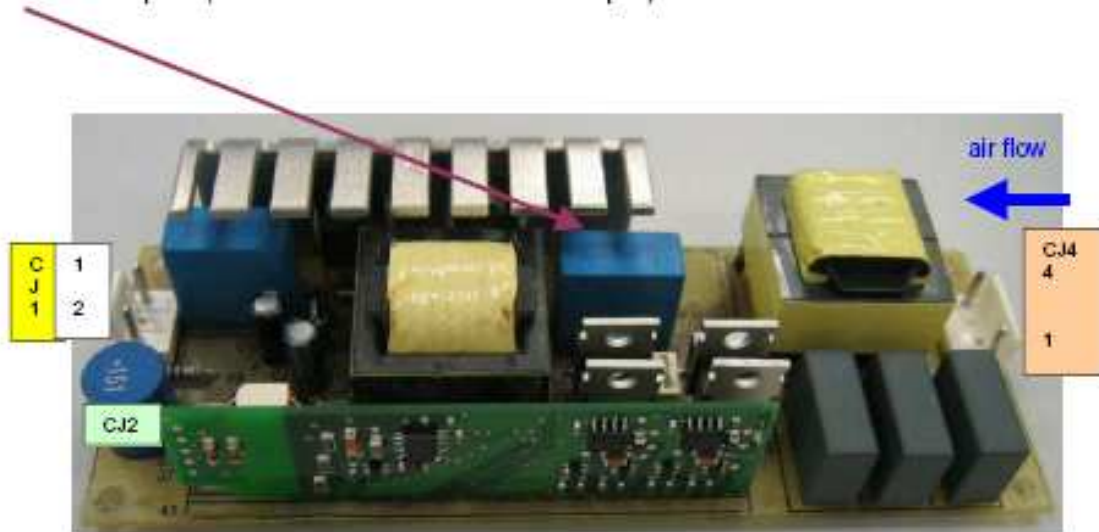

powersupply connector CJ1	pin 1	GND
	pin 2	+ 380V DC
lamp output connector CJ4	pin 1	lamp output
	pin 2	lamp output

Control board interface of ballast (CJ2)

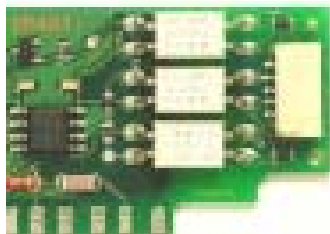

Pin 5
Pin 1

PIN 1	Flag / TxD+ (collector)
PIN 2	Flag / TxD- (emitter)
PIN 3	Common LED+ (anodes)
PIN 4	SCI / Sync. (cathode LED)
PIN 5	DIM / RxD (cathode LED)

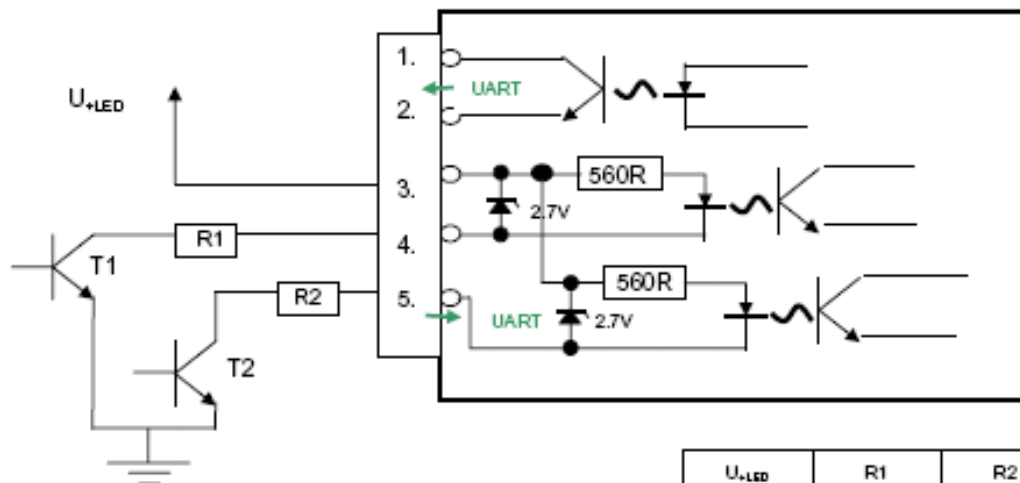

Dimensioning of LED series resistors R1, R2 @ 6mA:
LED interface current level requirement

- LED OFF current (Pin 4 or 5) 0 ... 0.1 mA
- LED ON current (Pin 4 or 5) 4..6..20 mA

U _{+LED}	R1	R2
2,7V	0R	0R
3,3V	100R	100R
5V	390R	390R
10V	1k2	1k2
15V	2k2	2k2

BALLAST FOR P5260E

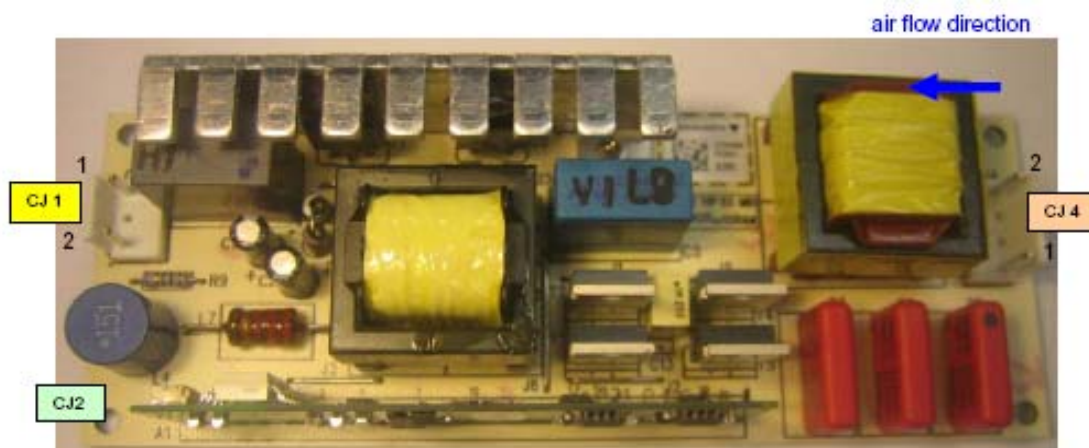

Power supply connector CJ1	pin 1	GND
	pin 2	+ 380V DC
lamp output connector CJ4	pin 1	lamp output
	pin 2	lamp output

Control board interface of ballast (CJ2)

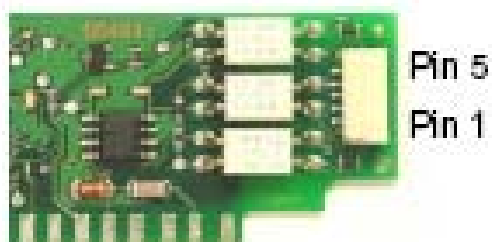

PIN 1	Flag / TxD+ (collector)
PIN 2	Flag / TxD- (emitter)
PIN 3	Common LED+ (anodes)
PIN 4	SCI / Sync. (cathode LED)
PIN 5	DIM / RxD (cathode LED)

5.3 Power board

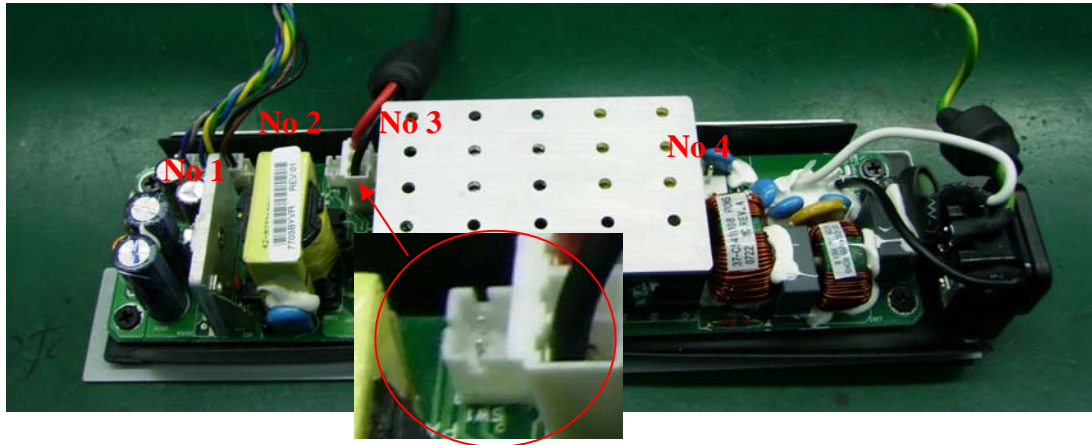

Connector	Description
No 1	Connect to main board
No 2	Safety switch
No 3	Power supply for ballast
No 4	Thermal sensor

Connector to main board details

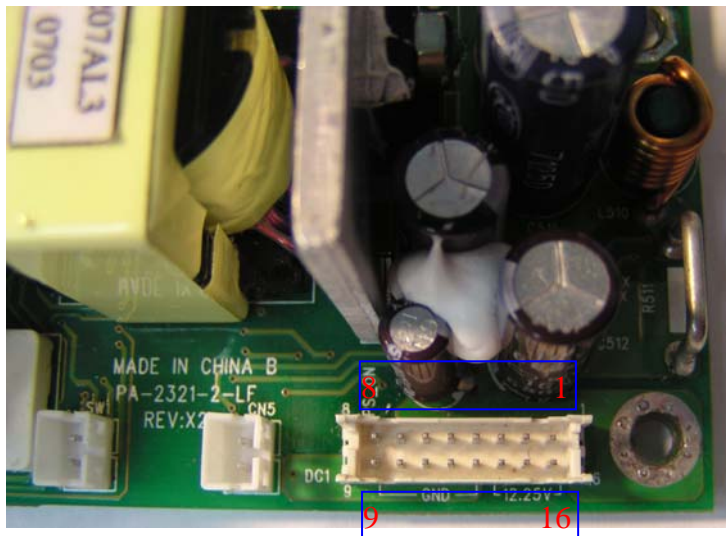

Pin	Signal	Pin	Signal
1	+12.25V	9	GND
2	+12.25V	10	GND
3	+12.25V	11	GND
4	GND	12	GND
5	GND	13	GND
6	GND	14	+12.25V
7	GND	15	+12.25V
8	PFC - ON	16	+12.25V

5.4 I/O Board

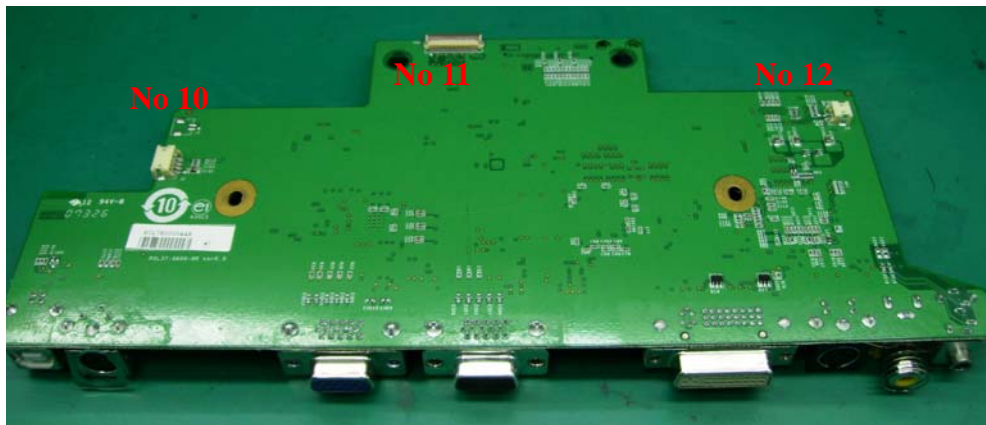
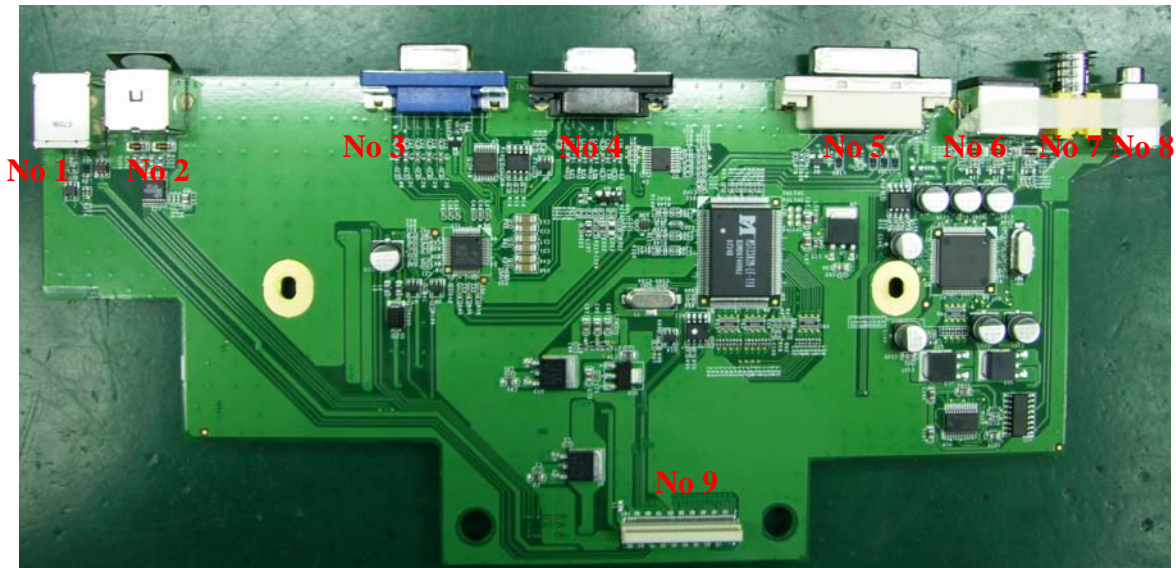

Connector	Description
No 1	USB Connector
No 2	RS232 Jack
No 3	VGA Input
No 4	VGA OUT
No 5	DVI input
No 6	S-VIDEO Jack
No 7	VIDEO Jack
No 8	Audio Jack
No 9	I/O board connector
No 10	Front IR board
No 11	Keypad connector
No 12	Speaker

Notes: There is one more VGA connector for Model P5260E than Model P1165E, and also a HDMI connector. The description just takes Model P1165E as example.

6 FRU (Field Replaceable Unit) List

Introduction

This section is a list of all the FRU removal. Following the FRU table of contents is an enlarged view of the entire projector, which shows the primary FRUs in the projector.

When working on the projector, use appropriate anti-static precautions such as anti-static mats, wrist straps and grounded work surfaces. Failure to do this can destroy static-sensitive components and make the product inoperable.

6.1 Mechanical Drawing

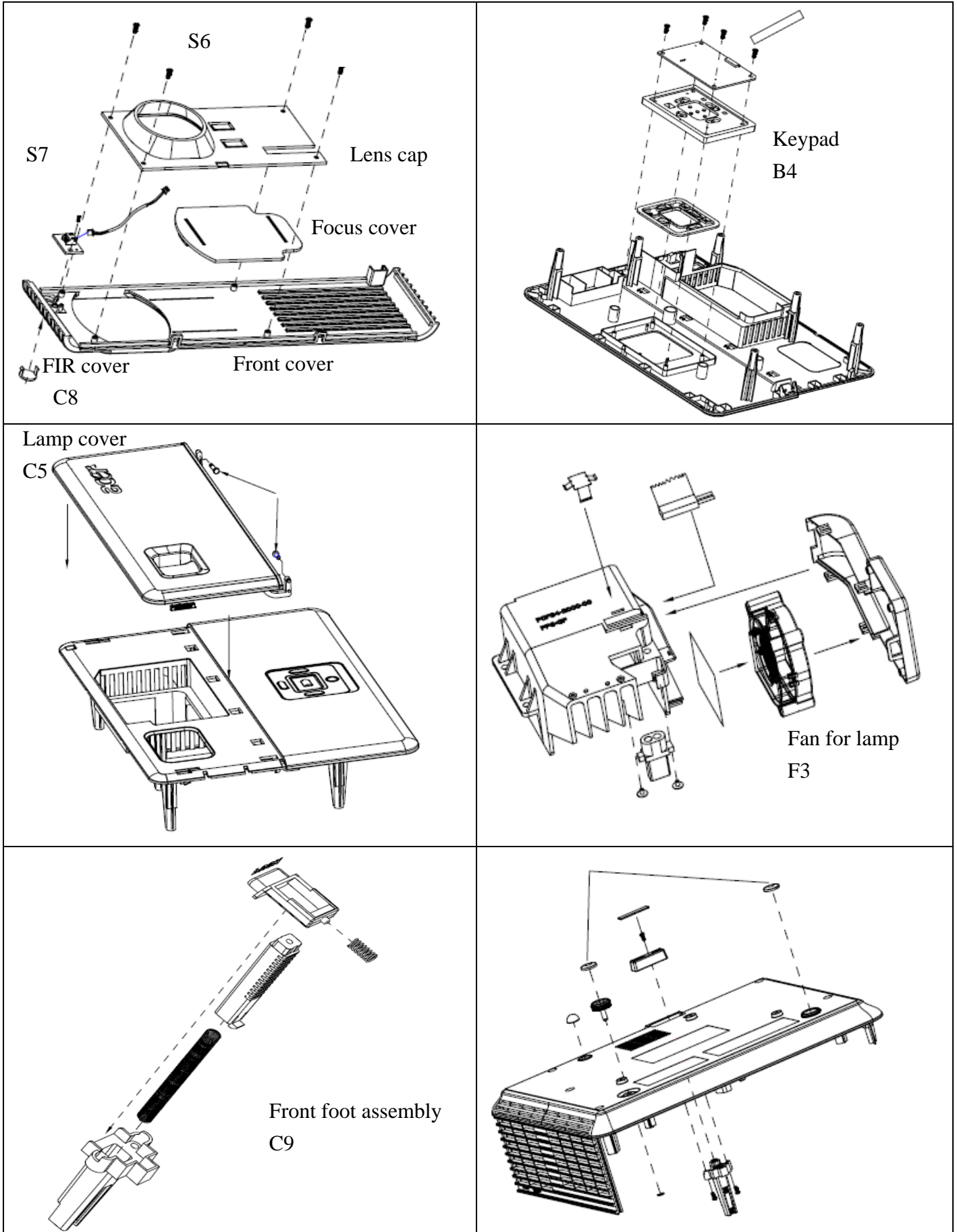

Lamp module assembly

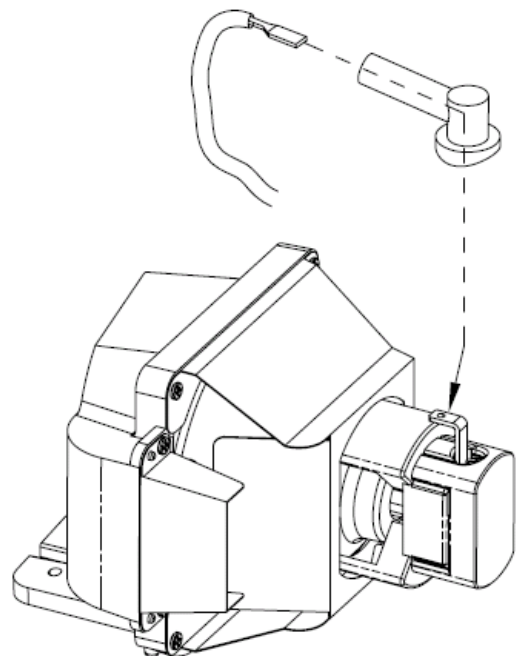
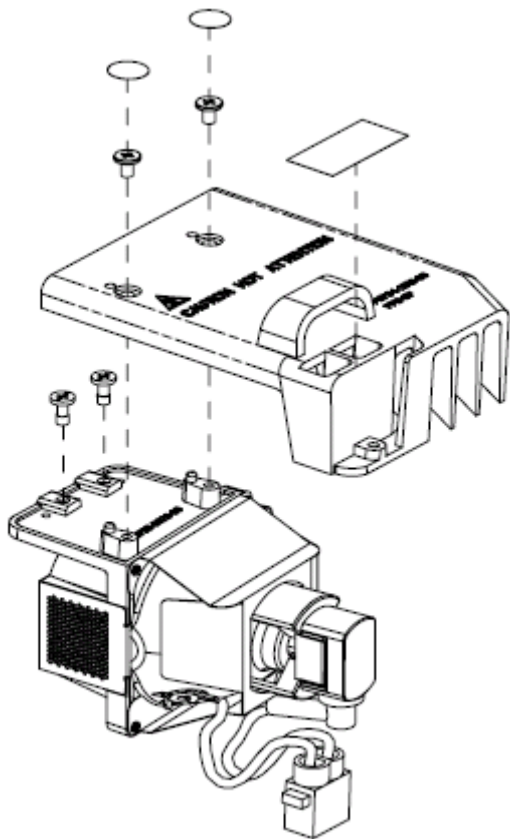
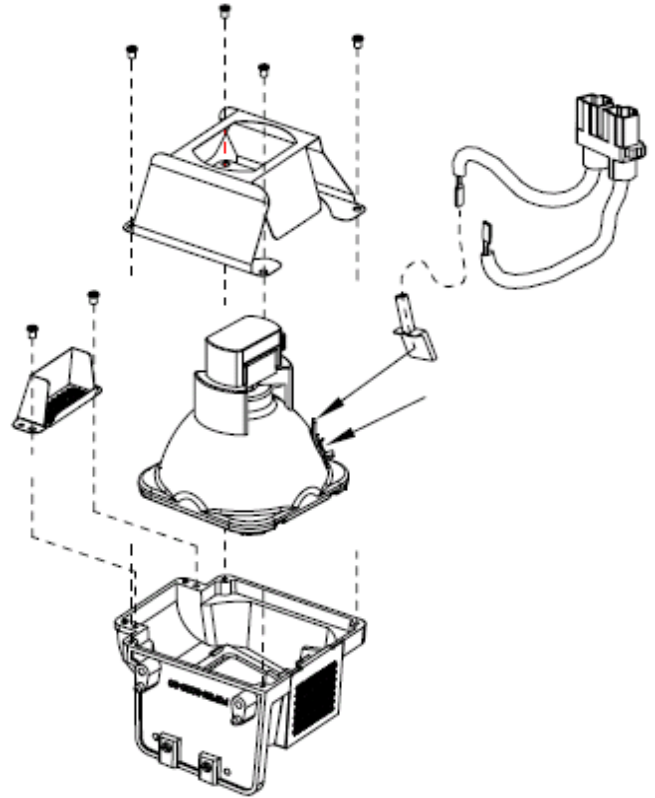
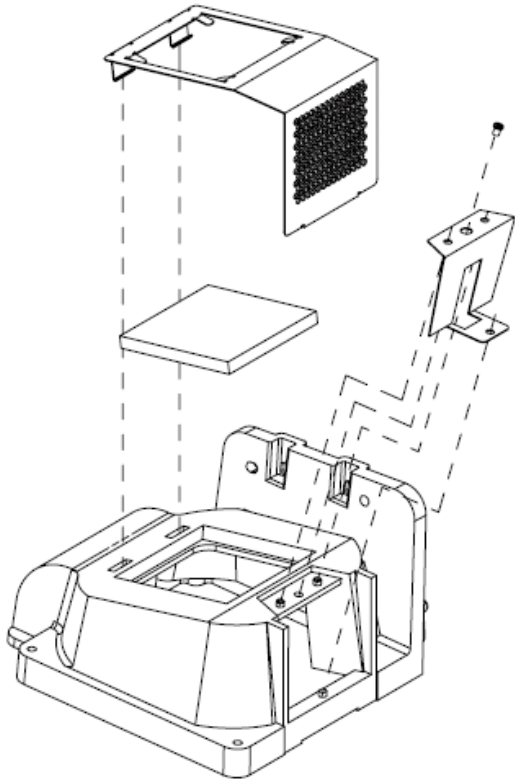

Engine body assembly

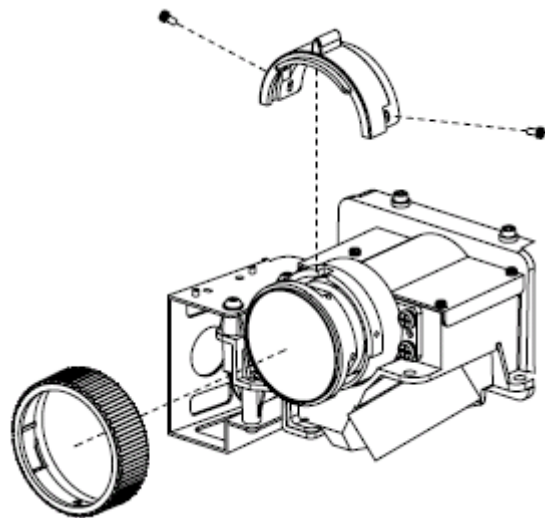
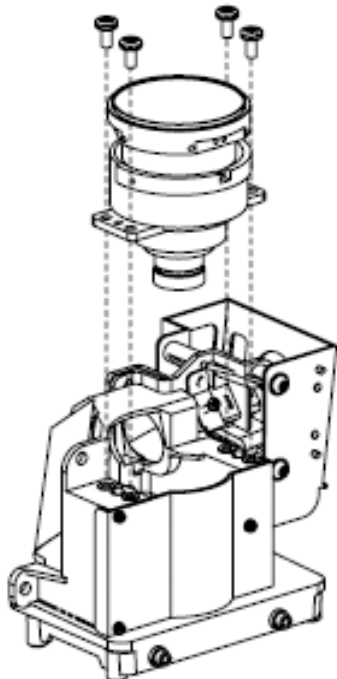
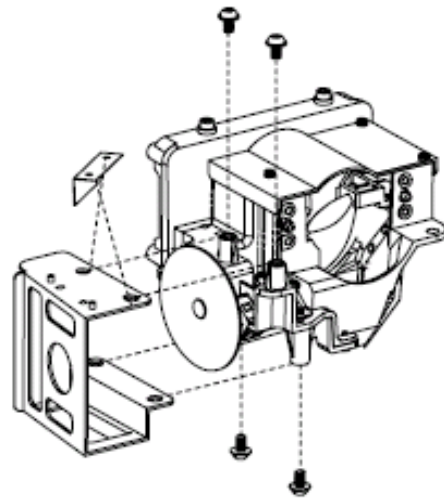
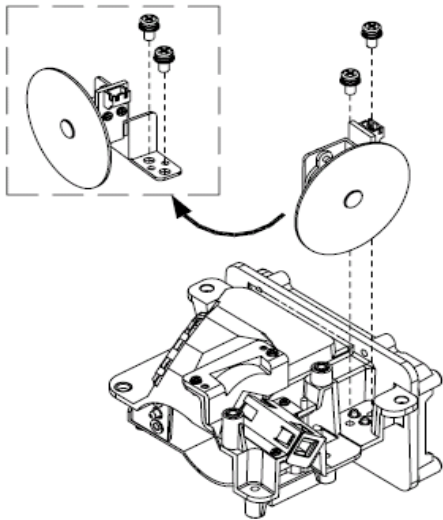
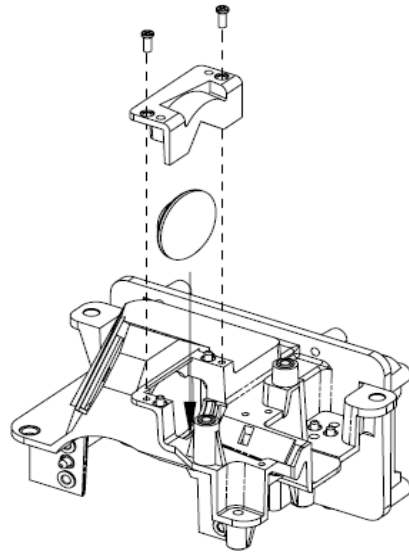
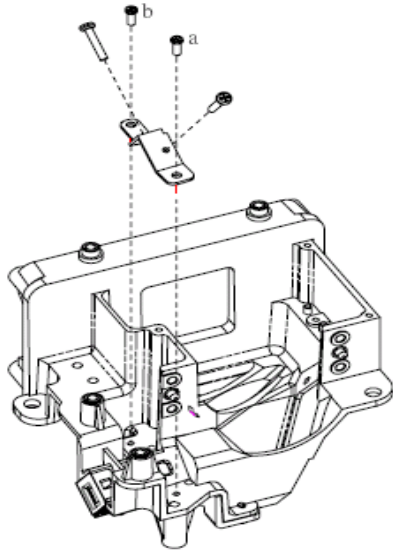

6.2 Accessory

Key No.	P/N	Description	P1165E	P5260E
RC	P0K00-RC01	ACER_REMOTE CONTROL_APD-X510_W/B_AAA2PCS	V	V

6.3 Board/Module

Key No.	P/N	Description	P1165E	P5260E
B1	P0L47-6100	IO_DIP_PCB_ASY_APD-S520_ROHS		V
	P0K47-6100	IO_DIP_PCB_ASY_APD-X510_ROHS	V	
B2	P0L43-1013	BALLAST-ASM_APD-S520_ROHS	V	
	P0K43-1013	BALLAST-ASM_APD-X510_ROHS		V
B3	P0K43-1018	LITEON-POWER-ASM_APD-X510_ROHS	V	V
B4	P0K43-1017	KEY-PAD-ASY_APD-X510_ROHS	V	V
B5	P0K47-5100	FIR SENSOR_DIP_PCB_ASY_APD-X510_ROHS	V	V
B6	P0F47-5000	CW SENSOR_SMT_PCB_ASY_PD-S550_ROHS	V	V

6.4 Case/Cover/Bracket Assembly

Key No.	P/N	Description	P1165E	P5260E
C1	P0L43-1011	TOP COVER_ASY_APD-S520_ROHS	V	
	P0K43-1011	TOP COVER_ASY_APD-X510_ROHS		V
C2	P0L43-1015	BOTTOM-COVER_ASY_APD-S520_ROHS	V	
	P0K43-1015	BOTTOM-COVER_ASY_APD-X510_ROHS		V
C3	P0K34-4550-00	LEFT-COVER_APD-X510_00_NO PAINTING_ROHS	V	V
C4	P0K43-1012	FRONT-COVER_ASY_APD-X510_ROHS	V	V
C5	P0L43-1010	LAMP COVER_ASY_APD-S520_ROHS	V	
	P0K43-1010	LAMP COVER_ASY_APD-X510_ROHS		V
C6	P0L43-1014	BACK COVER_ASY_APD-S520_ROHS	V	
	P0K43-1014	BACK COVER_ASY_APD-X510_ROHS		V
C7	P0L38-1560-00	IO-NAME-PLATE_APD-S520_ROHS	V	
	P0K38-1560-00	IO-NAME-PLATE_APD-X510_ROHS		V
C8	P0P34-4610-00	FRONT IR COVER	V	V
C9	P0P43-1050	FRONT FOOT ASSY	V	V

6.5 Fans

Key No.	P/N	Description	P1165E	P5260E
F1	J2394-0074-00	FAN._3110KL-04W-B39-S00(L=100MM)_NMB_ROHS	V	V
F2	J2394-0069-00	FAN._AUB0712M-R00(L=80)_DELTA_ROHS	V	V
F3	J2394-0087-00	FAN_BUB0512VHD-7T72(L=140MM)_DELTA_ROHS		V
	J2394-0070-00	FAN._BUB0512LD(L=60MM)_DELTA_ROHS	V	

6.6 Optical Device

Key No.	P/N	Description	P1165E	P5260E
O1	P0L43-1002	OPTICAL ENGINE_APD-S520	V	
	P0K43-1002	OPTICAL ENGINE_APD-X510		V
O2	P0L43-1005	LAMP MODULE_APD-S520_ROHS	V	
	P0K43-1005	LAMP MODULE_APD-X510_ROHS		V
O3	P0F36-7010-00	DMD-0.55 X-TYPE_PD-S550_ROHS	V	
	P0G36-7010-00	DMD-0.55XGA X-TYPE_PD-X550_ROHS		V
O4	P0K43-1006	COLORWHEEL MODULE_APD-X510_ROHS	V	V

6.7 Miscellaneous

Key No.	P/N	Description	P1165E	P5260E
M1	J2413-0024-03	SPEAKER_P28KC04-9-7JS5_VECO_ROHS	V	V

6.8 Wire

Key No.	P/N	Description	P1165E	P5260E
W1	J2591-0014-01	FFC CABLE_A28200C4466NB_ENTERY_0.5PITCH_28PIN	V	V
W2	J2595-0220-00	WIRE CON-CON_1102003-99_MSK_9PIN-2*8PIN_L105MM	V	V
W3	J2595-0231-00	WIRE ASSY_CON-SW	V	V
W4	J2595-0203-00	WIRE CON-CON_1102003-87_MSK_5PIN_L200MM	V	V
W5	J2595-0218-00	WIRE CON-CON_1102003-98_MSK_2PIN_L140MM		V
W6	J2595-0198-00	WIRE CON-MOTOR PROTECTOR	V	V
W7	J2595-0201-00	WIRE LAMP-BALA_2PIN_285MM	V	V
W8	J2595-0202-01	WIRE CON-CON_1102003-104_MSK_4PIN	V	V
W9	J2595-0208-00	WIRE ASSY_LAMP-BALA	V	V
W10	J2595-0066-00	WIRE CON-CON_1102003-36_MSK_4PIN_L50MM	V	V

6.9 Screws

Key No.	P/N	Description	P1165E	P5260E
S1	P2535-7350-00	SCREW-TB-Q669D715-10_EMS-DX540	V	V
S2	J1635-A491-00	SCREW-WASHER_TP_3_10_D_7_D=5.3	V	V
S3	82035-2510-00	HEXAGON-HEAT-BOLT-4.8_PJ-X900_3M	V	V
S4	J1635-3660-00	SCREW_M_3_5_D_2_D=5.5_NI	V	V
S5	J1635-D420-00	SCREW-WASHER_M_4_6_A_2.6_D=7	V	V
S6	J1635-3720-00	SCREW-WASHER_TP_2_4_D_1_D=3.2_NI	V	V
S7	J1635-A020-00	SCREW-WASHER_TP_2_3_D_1_D=3.2_NI	V	V
S8	J1635-B730-00	SCREW_M_3_5_E_1.2_D=6.5_BLACK	V	V
S9	J1635-3172-00	SCREW-WASHER_M_2_4_A_1.3_D=3.5_BLACK	V	V

Appendix : Service mode

1. Connect the power code and signal cable then turn on the "Power" button.
2. After PROJECTOR searched signal then press the "Left" button and "Power" button simultaneously. Keep 2~3 seconds then release 2 button. Press "MENU" button to enter the service mode.

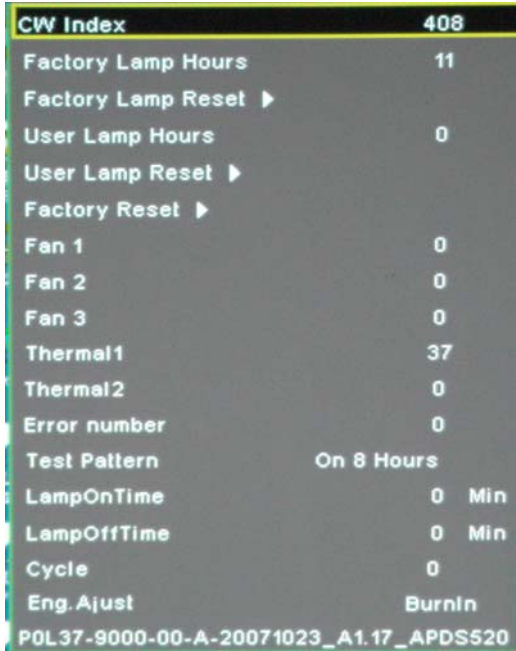

CW Index	408
Factory Lamp Hours	11
Factory Lamp Reset ▶	
User Lamp Hours	0
User Lamp Reset ▶	
Factory Reset ▶	
Fan 1	0
Fan 2	0
Fan 3	0
Thermal1	37
Thermal2	0
Error number	0
Test Pattern	On 8 Hours
LampOnTime	0 Min
LampOffTime	0 Min
Cycle	0
Eng. Ajust	BurnIn
P0L37-9000-00-A-20071023_A1.17_APDS520	

3. "Factory Lamp Hours" is lamp hour record. Press "Down" button to choose "Factory Lamp Reset" then press the "Right" button to reset the lamp hours.

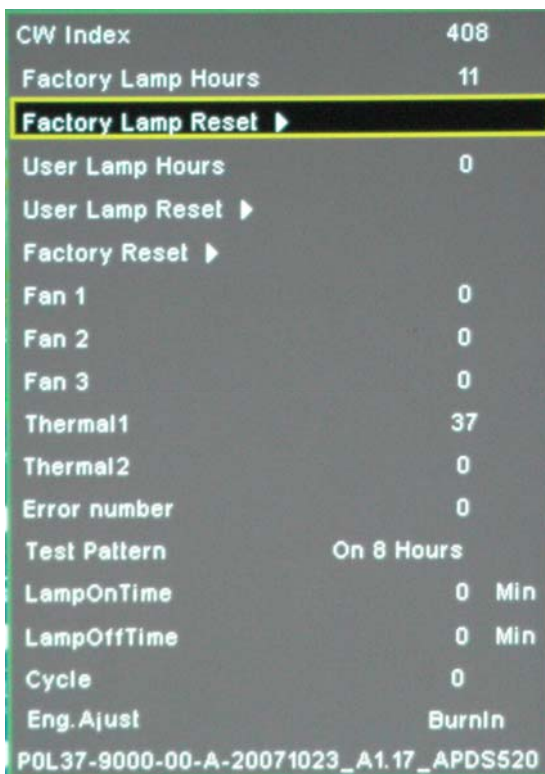

CW Index	408
Factory Lamp Hours	11
Factory Lamp Reset ▶	
User Lamp Hours	0
User Lamp Reset ▶	
Factory Reset ▶	
Fan 1	0
Fan 2	0
Fan 3	0
Thermal1	37
Thermal2	0
Error number	0
Test Pattern	On 8 Hours
LampOnTime	0 Min
LampOffTime	0 Min
Cycle	0
Eng. Ajust	BurnIn
P0L37-9000-00-A-20071023_A1.17_APDS520	