

S P E C F I L E

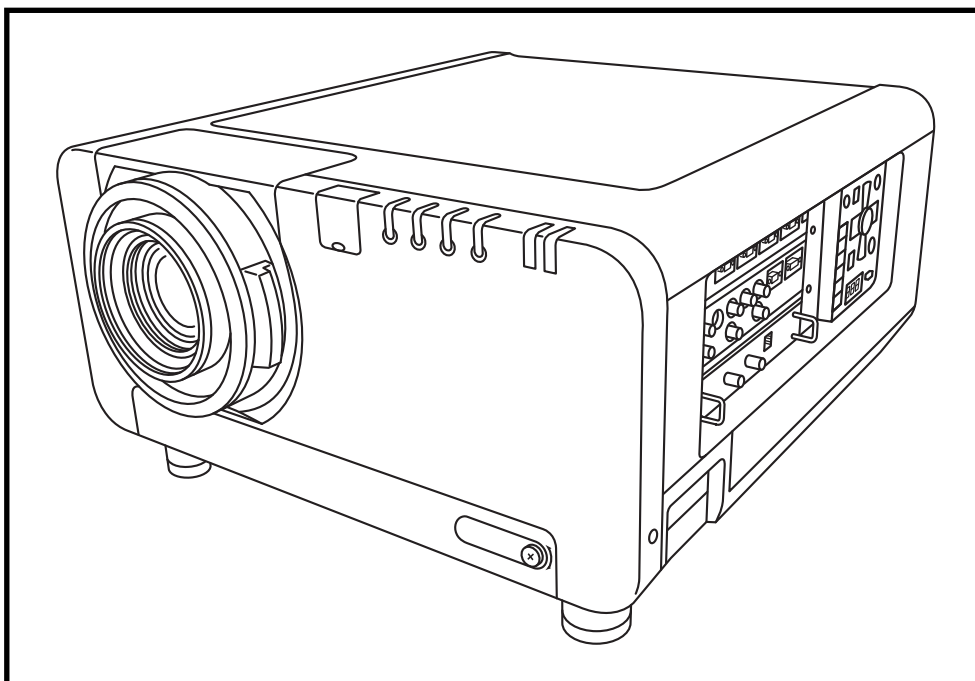

Product Number : **PT-D12000**

Product Name : 3-Chip DLP™ Projector

Specifications

Main Unit

Power supply:	North America:	120–240 V AC, 16–9.0 A, 50/60 Hz (3-wire single-phase)
	Europe, Asia	220–240 V AC, 9.5 A, 50/60 Hz (3-wire single-phase)
Power consumption:	North America:	1,600–1,500 W (10–15 W in standby mode with fan stopped)
	Europe, Asia	1,500 W (15 W in standby mode with fan stopped)
DLP™ chip:	Panel size:	0.95" diagonal (4:3 aspect ratio)
	Display method:	DLP™ chip x 3 (R, G, B), DLP™ projection system
	Pixels:	1,470,000 (1,400 x 1,050) x 3, total of 4,410,000 pixels
Lens:		Optional powered zoom/focus lenses
Lamp:		300 W UHM™ lamp x 4
Screen size:		70–600 inches, 4:3 aspect ratio (70–300 inches with the ET-D75LE5, 4:3 aspect ratio)
Brightness*1:		12,000 lumens (four-lamp operation mode)
Center-to-corner uniformity*1:		90%
Contrast*1:		5,000:1 (full on/full off, in dynamic iris 3 mode)
Resolution:		1,400 x 1,050 pixels (Input signals that exceed this resolution will be converted to 1,400 x 1,050 pixels.)
Scanning frequency:	RGB:	Horizontal: 15–100 kHz, Vertical: 24–120 Hz*2, Dot clock: 20–162 MHz
	YPbPr (YCbCr):	480i: fh 15.75 kHz; fv 60 Hz, 576i: fh 15.63 kHz; fv 50 Hz, 480p: fh 31.50 kHz; fv 60 Hz, 576p: fh 31.25 kHz; fv 50 Hz, 720/60p: fh 45.00 kHz; fv 60 Hz, 720/50p: fh 37.50 kHz; fv 50 Hz, 1035/60i: fh 33.75 kHz; fv 60 Hz, 1080/60i: fh 33.75 kHz; fv 60 Hz, 1080/50i: fh 28.13 kHz; fv 50 Hz, 1080/25p: fh 28.13 kHz; fv 25 Hz, 1080/24p: fh 27.00 kHz; fv 24 Hz, 1080/24sF: fh 27.00 kHz; fv 48 Hz, 1080/30p: fh 33.75 kHz; fv 30 Hz, 1080/60p: fh 67.50 kHz; fv 60 Hz, 1080/50p: fh 56.25 kHz; fv 50 Hz
	S-Video/Video:	Horizontal: 15.75/15.63 kHz, Vertical: 50/60 Hz, (NTSC, NTSC4.43, PAL, PAL60, PAL-N, PAL-M, SECAM)
Optical axis shift*3:	Vertical:	±50% (±40% with the ET-D75LE6) from center of screen, powered
	Horizontal:	±30% (±20% with the ET-D75LE6) from center of screen, powered
Keystone correction range:		Vertical: ±40° (±22° with the ET-D75LE5, ±28° with the ET-D75LE6), with geometric adjustment: vertical ±10°, horizontal ±15°
Installation:		Ceiling/floor, front/rear
Terminals:	DVI-D IN:	DVI-D 24-pin x 1, DVI 1.0 compliant, compatible with HDCP, compatible with single link only, 480p, 576p, 720/60p, 720/50p, 1080/60i, 1080/50i, 1080/24p, 1080/24sF, 1080/25p, 1080/30p, 1080/60p, 1080/50p VGA (640 x 480)–WUXGA*4 (1,920 x 1,200), compatible with non-interlaced signals only, dot clock: 25–162 MHz
	RGB1 IN:	BNC x 5
	R, G, B:	G: 0.7 Vp-p (1.0 Vp-p for sync on G), 75 ohms, B, R: 0.7 Vp-p, 75 ohms HD, VD, SYNC: 1.4–5.0 Vp-p, positive/negative automatic
	Y, Pb, Pr	Y: 1.0 p-p, 75 ohms (incl. sync signal), Pb/Pr: 0.7 Vp-p, 75 ohms 0.7 Vp-p (1.0 Vp-p for sync on G), 75 ohms

NOTE: HD/SYNC, and VD terminals do not accept 3-value direct sync signals.

RGB2 IN:	D-sub HD 15-pin x 1
R, G, B:	0.7 Vp-p (1.0 Vp-p for sync on G), 75 ohms
	HD, VD, SYNC: TTL, high impedance, positive/negative automatic
	VD: 1.4–5.0 Vp-p, positive/negative automatic, 75 ohms
Y, PB, PR	Y: 1.0 p-p, 75 ohms (incl. sync signal), PB/PR: 0.7 Vp-p, 75 ohms
	NOTE: HD/SYNC, and VD terminals do not accept 3-value direct sync signals.
VIDEO IN:	BNC x 1, 1.0 Vp-p, 75 ohms
VIDEO OUT:	BNC x 1, 1.0 Vp-p, active through
S-VIDEO IN:	Mini DIN 4-pin x 1
	Y: 1.0 Vp-p, C: 0.286 Vp-p, 75 ohms (S1 signal compatible)
LAN:	RJ-45 x 1, 10Base-T/100Base-TX, compatible with PJLink™ (class 1)
SERIAL IN*5:	D-sub 9-pin (female) x 2, for external control (RS-232C/RS-422 compliant)
SERIAL OUT*5:	D-sub 9-pin (male) x 1, for link control
REMOTE 1 IN:	M3 jack x 1 for wired remote control
REMOTE 1 OUT:	M3 jack x 1 for link control
REMOTE 2 IN:	D-sub 9-pin x 1 for external control (parallel)
Optional board slot*6:	
With ET-MD77SD1 installed:	SERIAL IN: BNC x 1, SD-SDI signal (YCbCr 4:2:2 10-bit):
	SMPTE 259M compliant: 480i, 576i
	SERIAL OUT: BNC x 1, active through
With ET-MD77SD3 installed:	SERIAL IN: BNC x 1
	SD-SDI signal (YCbCr 4:2:2 10-bit):
	SMPTE 259M compliant: 480i, 576i
	Single-link HD-SDI signal (YCbCr 4:2:2 10-bit):
	SMPTE 292M compliant: 720/50p, 720/60p, 1035/60i, 1080/50i,
	1080/60i, 1080/25p, 1080/24p, 1080/24sF, 1080/30p
	SERIAL OUT: BNC x 1, active through
With ET-MD100SD4 installed:	Link A/Link B IN: BNC x 1 for each
	SD-SDI signal (YCbCr 4:2:2 10-bit):
	SMPTE 259M compliant: 480i, 576i
	Single-link HD-SDI signal (YCbCr 4:2:2 10-bit):
	SMPTE 292M compliant: 720/50p, 720/60p, 1080/50i, 1080/60i,
	1080/25p, 1080/24p, 1080/24sF, 1080/30p
	Dual-link HD-SDI signal (RGB 4:4:4 12-bit/10-bit):
	SMPTE 372M compliant: 1920 x 1080/50i, 1920 x 1080/60i, 1920 x
	1080/25p, 1920 x 1080/24p, 1920 x 1080/24sF, 1920 x 1080/30p
	Dual-link HD-SDI signal (X'Y'Z' 4:4:4 12-bit):
	2048 x 1080/24p, 2048 x 1080/24sF
With ET-MD77DV installed:	DVI-D IN: DVI-D 24-pin x 1, DVI 1.0 compliant, compatible with HDCP, compatible with single link only,
	480p, 576p, 720/60p, 720/50p, 1080/60i, 1080/50i, 1080/24p,
	1080/24sF, 1080/25p, 1080/30p, 1080/60p, 1080/50p
	VGA (640 x 480)–WUXGA**4 (1,920 x 1,200), compatible with non-interlaced signals only, dot clock: 25–162 MHz
Power cord:	3 m/9.8'
Cabinet material:	Moulded plastic
Dimensions (W x H x D):	578 x 320 x 643 mm (22-3/4" x 12-19/32" x 25-5/16") (without lens)
Weight*7:	Approx. 35 kg (77.2 lbs) (without lens)

Operating temperature*8:	0°C–45°C (32°F–113°F)
Operating humidity:	10%–80% (no condensation)

Remote Control Unit

Number of functions:	35 keys, 39 functions
Power supply:	3 V DC (AA battery x 2)
Operation range*9:	Approx. 30 m (98.4') when operated from directly signal receptor
Dimensions (W x H x D):	51 x 22.7 x 176 mm (2" x 7/8" x 6-15/16")
Weight:	134 g (4.7 oz) (including batteries)

Supplied Accessories

Power cord
Wireless/wired remote control unit
Batteries for remote control (x 2)
Eye bolts (x 4)
Wire rope

Optional Accessories

Zoom lens (0.9–1.1:1):	ET-D75LE6
Zoom lens (1.4–1.8:1):	ET-D75LE1
Zoom lens (1.8–2.8:1):	ET-D75LE2
Zoom lens (2.8–4.6:1):	ET-D75LE3
Zoom lens (4.6–7.4:1):	ET-D75LE4
Zoom lens (7.3–13.8:1):	ET-D75LE8
Fixed-focus lens (0.7:1):	ET-D75LE5
SD-SDI board:	ET-MD77SD1
HD/SD-SDI board:	ET-MD77SD3
Dual link HD-SDI board:	ET-MD100SD4
DVI-D board:	ET-MD77DV
Replacement lamp unit	ET-LAD12K (one unit) ET-LAD12KF (a set of four lamps)
Ceiling mount bracket for high ceilings	ET-PKD100H
Ceiling mount bracket for low ceilings	ET-PKD100S
Frame	ET-PFD100
Carrying handle	ET-HAD100
Smoke cut filter	ET-SFD100

Weights and dimensions shown are approximate. Specifications subject to change without notice.

*1 Measurement, measuring conditions, and method of notation all comply with ISO 21118 international standards.

*2 Smooth image reproduction may not be possible when a motion video signal with a vertical frequency other than 50 or 60 Hz is input.

*3 Shift range is limited during simultaneous horizontal and vertical shifting.

*4 WUXGA resolution is supported only when the signals are compliant with VESA CVT-RB (Coordinated Video Timing-Reduced Blanking).

*5 Contact your dealers for details when the control using RS-232C or RS-422 is required.

*6 The LAN terminal on the optional board will be inactivated after installation. Use the LAN terminal on the main unit.

*7 Average value. May differ depending on models.

*8 The operating temperature range is 0°C (32°F) to 40°C (104°F) when used in High-Altitude mode (1,400 m [4,593 feet] to 2,700 m [8,858 feet]). Also, if the ambient temperature exceeds 40°C (104°F) (35°C [95°F] in High-Altitude mode) when using all four lamps, the light output may be reduced approximately 30% to protect the projector.

*9 Operation range differs depending on environments.

Shape of the plug receptacle

PT-D12000U

125 V AC, 20 A
(NEMA 5-20R)

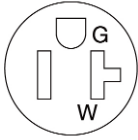

250 V AC, 15 A
(NEMA 6-15R)

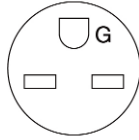

PT-D12000E

220-240V AC, 16 A

220-240V AC, 13 A/15 A

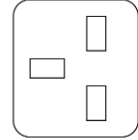
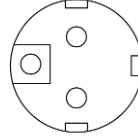

Note: Be sure to use the power plug adaptor cord supplied with the projector. The supplied power plug adaptor can be used with the PT-D12000 only.

Dimensions

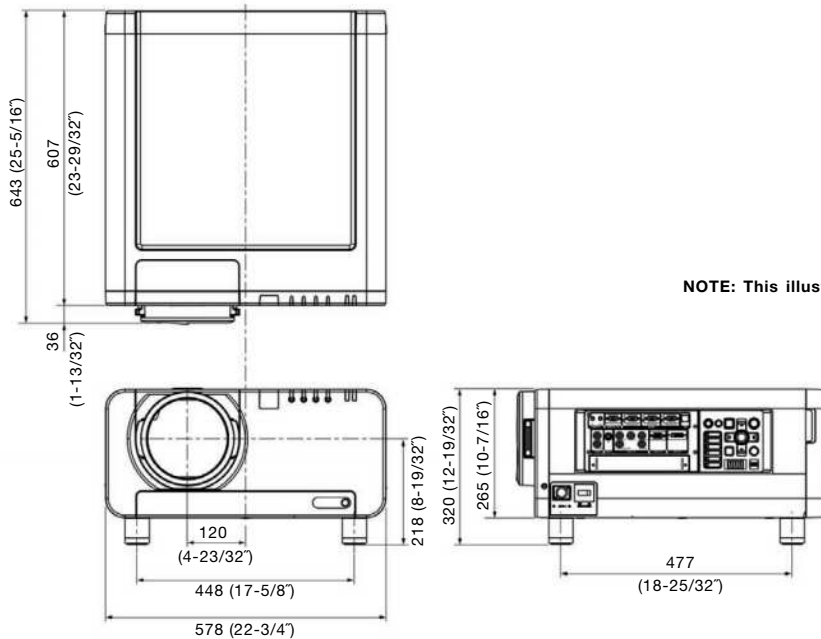

unit : mm (inch)
NOTE: This illustration is not drawn to scale.

Terminals

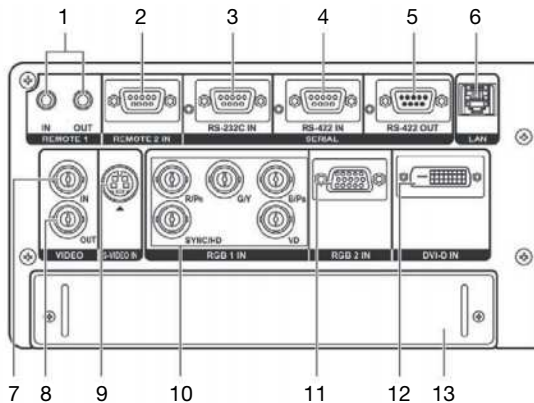

- 1 Remote 1 input/output
- 2 Remote 2 input
- 3 Serial input (RS-232C)
- 4 Serial input (RS-422)
- 5 Serial output (RS-422)
- 6 LAN connector (10Base-T/100Base-TX)
- 7 Video input
- 8 Video output
- 9 S-Video input
- 10 RGB 1 (YPbPr) input
- 11 RGB 2 Input
- 12 DVI-D input
- 13 Optional board slot

Standard setting-up positions

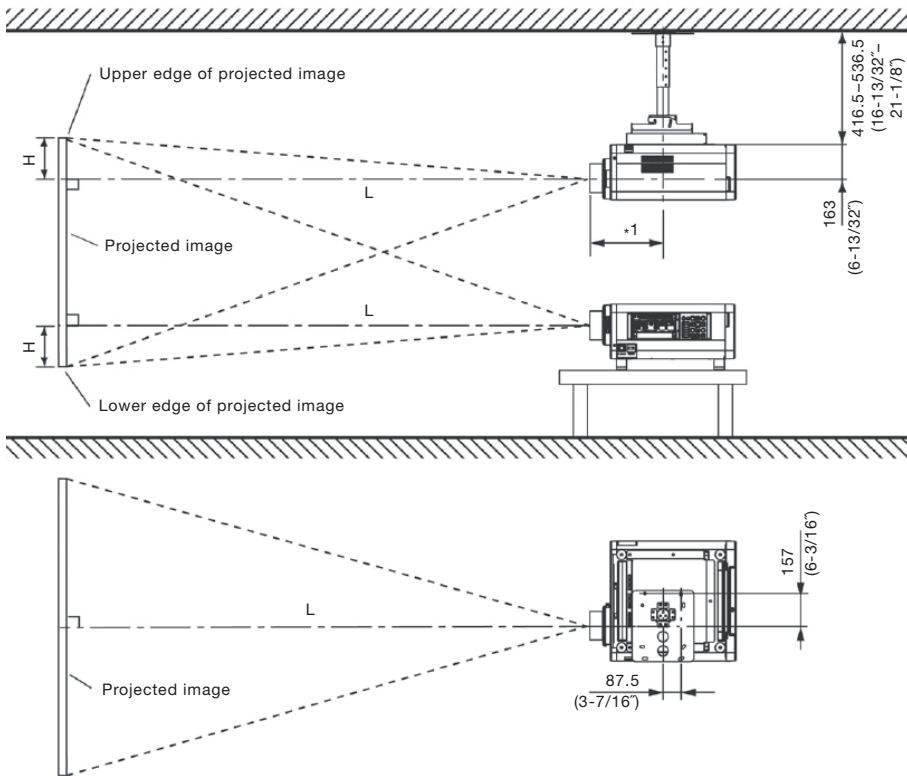

*1 When the lens protrudes to the maximum.
 414 mm (16-5/16") with the ET-D75LE6
 316.5 mm (12-15/32") with the ET-D75LE1
 301 mm (11-27/32") with the ET-D75LE2
 304.5 mm (12") with the ET-D75LE3
 328.4 mm (12-15/16") with the ET-D75LE4
 456.5 mm (17-31/32") with the ET-D75LE8
 404.5 mm (15-15/16") with the ET-D75LE5

unit : mm (inch)

NOTE:

Illustrations show the projector installed using optional ceiling bracket ET-PKD100H and an optional lens. This illustration is not drawn to scale.

Projection distance (screen aspect ratio 4:3)

Lens (Throw ratio)	Distance to screen												ET-D75LE5 Fixed-focus lens (0.8:1)	Height from the edge of screen to center of lens (H)						
	Zoom						Fixed-focus							Zoom lenses		Fixed-focus lens*2				
	ET-D75LE6 Zoom lens (1.0-1.2:1)		ET-D75LE1 Zoom lens (1.5-2.0:1)		ET-D75LE2 Zoom lens (2.0-3.0:1)		ET-D75LE3 Zoom lens (3.0-5.0:1)		ET-D75LE4 Zoom lens (5.0-8.0:1)		ET-D75LE8 Zoom lens (7.9-15.0:1)			ET-D75LE6 except ET-D75LE6						
min.	max.	min.	max.	min.	max.	min.	max.	min.	max.	min.	max.	min.	max.	min.	max.	min.	max.	min.	max.	
70	1,393 4.6	1,662 5.5	2,072 6.8	2,768 9.1	2,801 9.2	4,215 13.8	4,226 13.9	7,094 23.3	7,101 23.3	11,374 37.3	11,091 36.4	21,142 69.4	1,022 3.4	0-1,067 0-3.50	107-960 0.35-3.15	533 1.75				
80	1,600 5.2	1,910 6.3	2,379 7.8	3,178 10.4	3,212 10.5	4,832 15.9	4,843 15.9	8,125 26.7	8,132 26.7	13,013 42.7	12,730 41.8	24,214 79.4	1,180 3.9	0-1,219 0-4.00	122-1,097 0.40-3.60	610 2.00				
90	1,807 5.9	2,158 7.1	2,686 8.8	3,588 11.8	3,624 11.9	5,449 17.9	5,460 17.9	9,156 30.0	9,163 30.1	14,652 48.1	14,370 47.1	27,286 89.5	1,338 4.4	0-1,372 0-4.50	137-1,234 0.45-4.05	686 2.25				
100	2,014 6.6	2,406 7.9	2,992 9.8	3,998 13.1	4,035 13.2	6,067 19.9	6,077 19.9	10,187 33.4	10,193 33.4	16,292 53.5	16,009 52.5	30,358 99.6	1,496 4.9	0-1,524 0-5.00	152-1,372 0.50-4.50	762 2.50				
120	2,428 8.0	2,902 9.5	3,606 11.8	4,817 15.8	4,858 15.9	7,301 24.0	7,312 24.0	12,248 40.2	12,255 40.2	19,570 64.2	19,288 63.3	36,501 119.8	1,812 5.9	0-1,829 0-6.00	183-1,646 0.60-5.40	914 3.00				
150	3,049 10.0	3,646 12.0	4,526 14.8	6,047 19.8	6,093 20.0	9,153 30.0	9,164 30.0	15,341 50.3	15,348 50.4	24,488 80.3	24,207 79.4	45,717 150.0	2,286 7.5	0-2,286 0-7.50	229-2,057 0.75-6.75	1,143 3.75				
200	4,084 13.4	4,886 16.0	6,060 19.9	8,096 26.6	8,150 26.7	12,240 40.2	12,250 40.2	20,496 67.2	20,502 67.3	32,685 107.2	32,404 106.3	61,076 200.4	3,076 10.1	0-3,048 0-10.00	305-2,743 1.00-9.00	1,524 5.00				
250	5,119 16.8	6,126 20.4	7,594 24.9	10,145 33.3	10,208 33.5	15,326 50.3	15,337 50.3	25,650 84.2	25,657 84.2	40,881 134.1	40,602 133.2	76,435 250.8	3,866 12.7	0-3,810 0-12.50	381-3,429 1.25-11.25	1,905 6.25				
300	6,154 20.2	7,366 24.2	9,128 29.9	12,194 40.0	12,265 40.2	18,413 60.4	18,423 60.4	30,805 101.1	30,811 101.1	49,078 161.0	48,799 160.1	91,794 301.2	4,656 15.3	0-4,572 0-15.00	457-4,115 1.50-13.50	2,286 7.50				
400	8,224 27.0	9,846 32.3	12,196 40.0	16,292 53.5	16,380 53.7	24,586 80.7	24,596 80.7	41,114 134.9	41,120 134.9	65,471 214.8	65,194 213.9	122,512 401.9	-	0-6,096 0-20.00	610-5,486 2.00-18.00	-				
500	10,294 33.8	12,326 40.4	15,264 50.0	20,390 66.9	20,495 67.2	30,759 100.9	30,769 100.9	51,423 168.7	51,429 168.7	81,864 268.6	81,589 267.7	153,230 502.7	-	0-7,620 0-25.00	762-6,858 2.50-22.50	-				
600	12,364 40.6	14,806 48.6	18,332 60.1	24,488 80.3	24,610 80.7	36,932 121.2	36,942 121.2	61,732 202.5	61,738 202.6	98,257 322.4	97,984 321.5	183,948 603.5	-	0-9,144 0-30.00	914-8,230 3.00-27.00	-				

- The figures in the above table may vary by approximately ±5% depending on the projection lens that is used.
 - When vertical keystone correction is used, the image is corrected in the direction that reduces its projected size.
 - At the shortest projection distance, the zoom lens characteristics may cause slight image distortion.
- *2: The shift range function does not operate when the fixed-focus lens is installed.

millimeters
feet

Calculation of the projection distance

For a screen size different from the above, use the equation below to calculate the projection distance.

4:3 aspect ratio	ET-D75LE6	minimum	$L \text{ (mm)} = (\text{diagonal screen size in inches}) \times 20.7 - 56.6$
		maximum	$L \text{ (mm)} = (\text{diagonal screen size in inches}) \times 24.8 - 73.6$
	ET-D75LE1	minimum	$L \text{ (mm)} = (\text{diagonal screen size in inches}) \times 30.68 - 76.0$
		maximum	$L \text{ (mm)} = (\text{diagonal screen size in inches}) \times 40.98 - 100.4$
	ET-D75LE2	minimum	$L \text{ (mm)} = (\text{diagonal screen size in inches}) \times 41.15 - 79.5$
		maximum	$L \text{ (mm)} = (\text{diagonal screen size in inches}) \times 61.73 - 106.4$
	ET-D75LE3	minimum	$L \text{ (mm)} = (\text{diagonal screen size in inches}) \times 61.73 - 95.8$
		maximum	$L \text{ (mm)} = (\text{diagonal screen size in inches}) \times 103.09 - 121.6$
	ET-D75LE4	minimum	$L \text{ (mm)} = (\text{diagonal screen size in inches}) \times 103.09 - 115.8$
		maximum	$L \text{ (mm)} = (\text{diagonal screen size in inches}) \times 163.93 - 101.3$
	ET-D75LE8	minimum	$L \text{ (mm)} = (\text{diagonal screen size in inches}) \times 163.95 - 386.2$
		maximum	$L \text{ (mm)} = (\text{diagonal screen size in inches}) \times 307.18 - 359.8$
	ET-D75LE5	(fixed focus)	$L \text{ (mm)} = (\text{diagonal screen size in inches}) \times 15.798 - 83.5$

- The figures in the above table may vary by approximately ±5% depending on the projection lens that is used.
- When vertical keystone correction is used, the image is corrected in the direction that reduces its projected size.
- At the shortest projection distance, the zoom lens characteristics may cause slight image distortion.

Installable Angle

Install the projector at an angle within the range shown below.

• Vertical direction

The projector may be installed at a vertical angle of 360°.

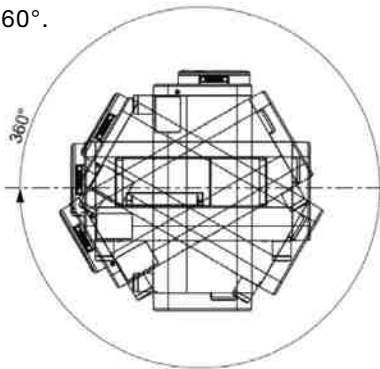

• Horizontal direction

The projector may be installed at a horizontal angle of ±15°.

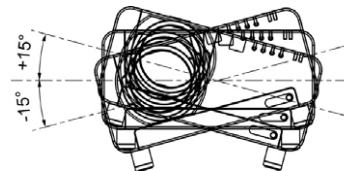

Shift range

Optical axis shift function allows to shift the position of a projected image as shown below.

ET-D75LE1/D75LE2/D75LE3/D75LE4/D75LE8

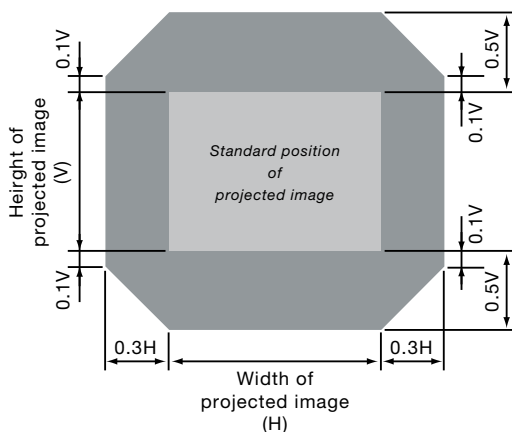

ET-D75LE6

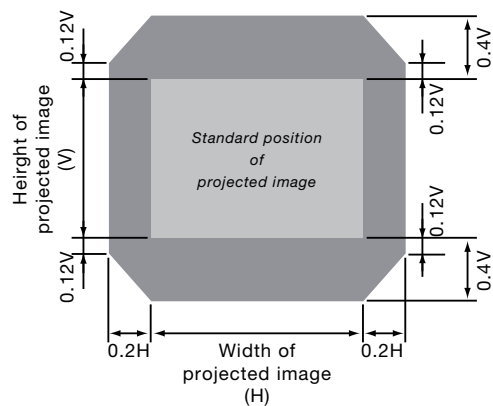

- Because the ETD75LE5 is a fixed short-throw lens, the lens shift function cannot be used with it.

List of compatible signals

This projector supports RGB signals with horizontal frequencies of 15 to 100 kHz, vertical frequencies of 24 to 120 Hz and dot clock frequencies of 20 MHz to 162 MHz.

NOTE: The native resolution of this projector is 1,400 x 1,050 pixels. If the display resolution of the input signal is different from the native resolution, image compression or expansion will be used to convert the input signal to a level within the native resolution.

Display mode	Display resolution (dots) ¹	Scanning frequency		Dot clock frequency (MHz)	Format	Plug and Play compatibility		
		H (kHz)	V (kHz)			RGB 2 input	DVI-D input EDID1	EDID2
NTSC/NTSC4.43/PAL-M/PAL60	720 x 480i	15.7	59.9	–	VIDEO/S-VIDEO	–	–	–
PAL/PAL-N/SECAM	720 x 576i	15.6	50.0	–				
480i	720 x 480i	15.7	59.9	13.5	YPbPr/RGB	–	–	–
576i	720 x 576i	15.6	50.0	13.5				
480p	720 x 483	31.5	59.9	27.0	YPbPr/RGB/DVI	No	Yes	No
576p	720 x 576	31.3	50.0	27.0				
720/60p	1,280 x 720	45.0	60.0	74.3				
720/50p		37.5	50.0	74.3				
1080/60i	1,920 x 1,080i	33.8	60.0	74.3				
1080/50i		28.1	50.0	74.3				
1080/24p	1,920 x 1,080	27.0	24.0	74.3				No
1080/24sF	1,920 x 1,080i	27.0	24.0	74.3				No
1080/25p	1,920 x 1,080	28.1	50.0	74.3		No	Yes	No
1080/30p		33.8	60.0	74.3				No
1080/60p		67.5	60.0	148.5		No	Yes	NO
1080/50p		56.3	50.0	148.5				
VGA400	640 x 400	31.5	70.1	25.2	RGB/DVI			No
		37.9	85.1	31.5				
VGA480	640 x 480	31.5	59.9	25.2	RGB/DVI			Yes
		35.0	66.7	30.2				No
		37.9	72.8	31.5		Yes	No	Yes
		37.5	75.0	31.5				
		43.3	85.0	36.0				No
SVGA	800 x 600	35.2	56.3	36.0		Yes	No	Yes
		37.9	60.3	40.0				
		48.1	72.2	50.0				
		46.9	75.0	49.5				
		53.7	85.1	56.3				No
MAC16	832 x 624	49.7	74.6	57.3		Yes	No	Yes
XGA	1,024 x 768	39.6	50.0	51.9				No
		48.4	60.0	65.0		Yes	No	Yes
		56.5	70.1	75.0				
		60.0	75.0	78.8				
		65.5	81.6	86.0				No
		68.7	85.0	94.5				
	1,024 x 768i	35.5	87.0	44.9	RGB	Yes		No
	1,024 x 768	80.0	100.0	105.0	RGB/DVI			No
		96.7	120.0	130.0				
MXGA	1152 x 864	64.0	71.2	94.2				
		67.5	74.9	108.0				
		76.7	85.0	121.5				
MAC21	1152 x 870	68.7	75.1	100.0		Yes	No	Yes
1280 x 768	1,280 x 768	39.6	49.9	65.3				No
		47.8	59.9	79.5				
1280 x 80	1,280 x 800	41.3	50.0	68.0				
		49.7	59.8	83.5				
MSXGA	1,280 x 960	60.0	60.0	108.0				
SXGA	1,280 x 1,024	52.4	50.0	88.0				
		64.0	60.0	108.0		Yes	No	Yes
		72.3	66.3	125.0				No
		78.2	72.0	135.1				
		80.0	75.0	135.0		Yes	No	Yes
		91.1	85.0	157.5				No
SXGA+	1,400 x 1050	65.2	60.0	122.6		Yes	No	Yes
		78.8	72.0	149.3				No
		82.2	75.0	155.9				
WXGA+	1,440 x 900	55.9	59.9	106.5				
UXGA	1,600 x 1,200	75.0	60.0	162.0		Yes	No	Yes
WSXGA+	1,680 x 1,050	65.3	60.0	146.3				No
1920 x 1080 ²	1,920 x 1,080	66.6	59.9	138.5				
WUXGA ²	1,920 x 1,200	74.0	60.0	154.0		Yes	No	Yes

1. The “i” appearing after the resolution indicates an interlaced signal. Line flicker occurs when an interlaced signal is input.
 2. WUXGA resolution is supported only when the signals are compliant with VESA CVT-RB (Coordinated Video Timing-Reduced Blanking).

Serial connector

The serial connector complies with RS-232C. To control the projector from a personal computer, commands must be input through communication software, based on the format and satisfying the communication conditions shown below.

Pin assignments and signal names

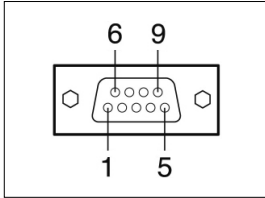

D-sub 9-pin (female)
Serial input

No.	Signal name	Description	No.	Signal name	Description
1	-	NC	6	-	NC
2	TXD	Send data	7	CTS	Connected internally
3	RXD	Receive data	8	RTS	Connected internally
4	-	Connected internally	9	-	NC
5	GND	Ground			

Pin assignments and signal names

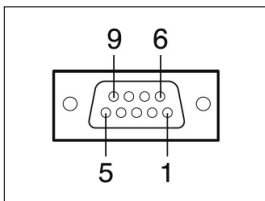

D-sub 9-pin (male)
Serial output

No.	Signal name	Description	No.	Signal name	Description
1	-	NC	6	-	NC
2	RXD	Receive data	7	RTS	Connected internally
3	TXD	Send data	8	CTS	Connected internally
4	-	Connected internally	9	-	NC
5	GND	Ground			

Communication conditions (factory setting)

Signal level	RS-232C-compliant
Synchronization method	Start-stop synchronization
Baud rate	9,600 bps
Parity	None
Character length	8 bits
Stop bit	1 bit
X parameter	None
S parameter	None

Basic format

Transmission from the computer begins with STX, then the ID, command, parameter, and ETX are sent in this order. Add parameters according to the details of control.

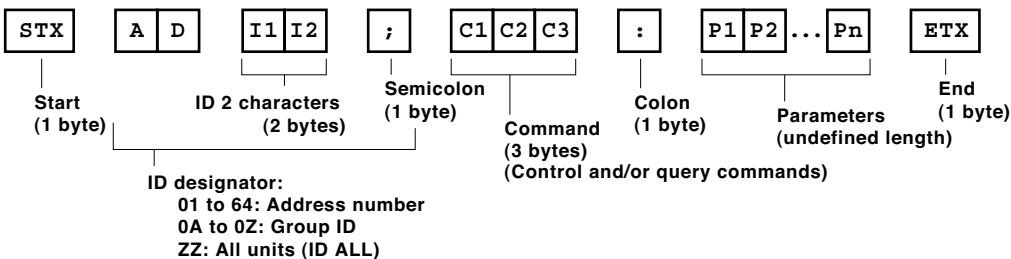

CAUTION

- It may not be possible to send or receive commands for about 10 to 60 seconds when the lamp is first turned on. If this occurs, wait for 60 seconds, then try sending or receiving again.
- When sending multiple commands, be sure to wait for at least 0.5 second after receiving a response from the projector before sending the next command.
- Additional time is sometimes required for response due to processing inside the projector. Set the time-out period for command response to 10 seconds or more.

Cable specifications

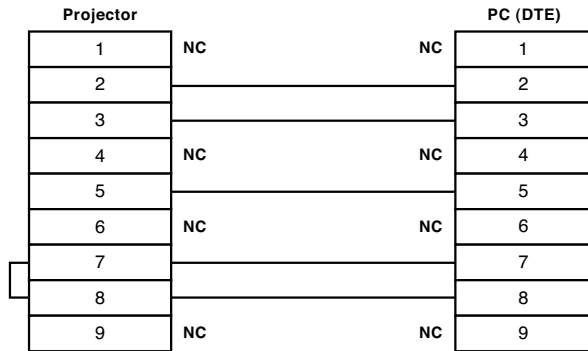

Control commands

Command : Parameter	Function		Callback
PON	POWER (STANDBY)	Standby power on	PON
POF		Standby power off	POF
IIS:RG1	INPUT SELECT	RGB 1	IIS:RG1
IIS:RG2		RGB 2	IIS:RG2
IIS:VID		Video	IIS:VID
IIS:SVD		S-Video	IIS:SVD
IIS:DVI		DVI	IIS:DVI
IIS:AUX		AUX	IIS:AUX
LPM:0	LAMP SELECT	Quad (four lamps)	LPM:0
LPM:1		Lamp 1 + 4	LPM:1
LPM:2		Lamp 2 + 3	LPM:2
LPM:3		Dual (two lamps)	LPM:3
LPM:4		Lamp 1 + 2 + 3	LPM:4
LPM:5		Lamp 1 + 2 + 4	LPM:5
LPM:6		Lamp 1 + 3 + 4	LPM:6
LPM:7		Lamp 2 + 3 + 4	LPM:7
LPM:8		Triple (three lamps)	LPM:8
LPM:9		Lamp 1	LPM:9
LPM:10		Lamp 2	LPM:10
LPM:11		Lamp 3	LPM:11
LPM:12		Lamp 4	LPM:12
LPM:13		Single lamp	LPM:13
OSH:1	SHUTTER	Shutter on	OSH:1
OSH:0		Shutter off	OSH:0
OPP:0	P IN P SELECT	P in P off	OPP:0
OPP:1		User 1	OPP:1
OPP:2		User 2	OPP:2
OPP:3		User 3	OPP:3
OAS	AUTO SETUP		OAS
VPM:NAT	PICTURE MODE	Natural	VPM:NAT
VPM:STD		Standard	VPM:STD
VPM:DYN		Dynamic	VPM:DYN
VPM:CIN		Cinema	VPM:CIN
VPM:GRA		Graphic	VPM:GRA
OTE:0	COLOR TEMPERATURE	Low	OTE:0
OTE:1		Middle	OTE:1
OTE:2		High	OTE:2
OTE:4		User 1	OTE:4
OTE:9		User 2	OTE:9
OTE:10		Default	OTE:10
TSD:y1y2y3y4m1m2d1d2w	DATE	Date setting	TSD:y1y2y3y4m1m2d1d2w
TST:h1h2m1m2s1s2	TIME	Time setting	TST:h1h2m1m2s1s2
OOS:1	ON SCREEN	On-screen display on	OOS:1
OOS:0		On-screen display off	OOS:0

Status asking commands

Command:Parameter	Function	Callback	Description
QPW	Main power status	001	On
		000	Off
QSH	Shutter function status	1	On
		0	Off
QIN	Input signal status	RG1	RGB 1
		RG2	RGB 2
		VID	Video
		SVD	S-Video
		DVI	DVI
		AUX	AUX
QOS	On-screen display status	1	On
		0	Off
QST	Projector run time	00000-99999	0000h-9999h
Q\$L:p1	Lamp 1 run time	0000-9999	0000h-9999h
Q\$L:p2	Lamp 2 run time	0000-9999	0000h-9999h
Q\$L:p3	Lamp 3 run time	0000-9999	0000h-9999h
Q\$L:p4	Lamp 4 run time	0000-9999	0000h-9999h
QSL	Lamp operation mode status	0	Quad (four lamps)
		1	Lamp 1 + 4
		2	Lamp 2 + 3
		3	Dual (two lamps)
		4	Lamp 1 + 2 + 3
		5	Lamp 1 + 2 + 4
		6	Lamp 1 + 3 + 4
		7	Lamp 2 + 3 + 4
		8	Triple (three lamps)
		9	Lamp 1
		10	Lamp 2
		11	Lamp 3
		12	Lamp 4
QIB	Optional board slot status	13	Single lamp
		MD77SD1	ET-MD77SD1
		MD77SD3	ET-MD77SD3
		MD100SD4	ET-MD100SD4
		MD77DV	ET-MD77DV
		NONE	Uninstalled
QPP	P in P status	UNKNOWN	Unknown
		NOT SUPPORT	Not supported
		0	Off
QGD	Date setting status	1	User 1
		2	User 2
		3	User 3
QGT	Time setting status	y1y2y3y4m1m2d1d2w	yyyymmdd (day of week) (*1)
		h1h2m1m2s1s2	hhmmss (*2)

*1 Day of week: Monday = 1, Tuesday = 2, ... Sunday = 7
 *2 Set the date and time to UTC (universal time coordinated).

NOTE: If a wrong command is received, the projector will send an ER401 or ER402 command to the computer.

Command example

To set the on-screen display off, send the command as shown below.

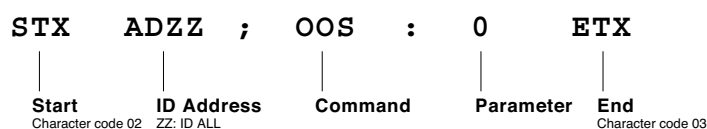

NOTE: When sending commands without parameters, a colon (:) is not necessary.

Notes on Projector Placement and Operation

The projector uses a high-wattage lamp that becomes very hot during operation. Please observe the following precautions.

1. Never place objects on top of the projector while it is operating.
2. Make sure there is an unobstructed space of 500 mm (19-11/16") or more around the projector's exhaust openings.
3. Do not stack projector units directly on top of one another for the purpose of multiple (stacked) projection. When stacking projector units, be sure to provide the amount of space indicated below between them. These space requirements also apply to installations where only one projector unit is operating at one time and the other unit is used as a backup.
4. If the projector is placed in a box or enclosure, ensure the temperature of the air surrounding the projector is between 0°C/32°F and 40°C/104°F. Also make sure the projector's intake and exhaust openings are not blocked. Take particular care to ensure that hot air from the exhaust openings is not sucked into the intake openings.

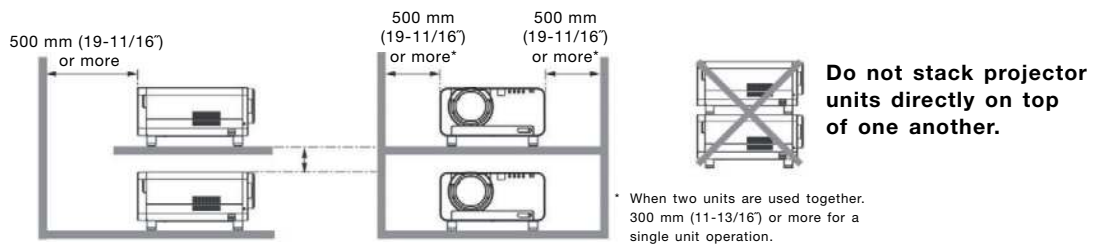

Direction of Air Intake and Exhaust

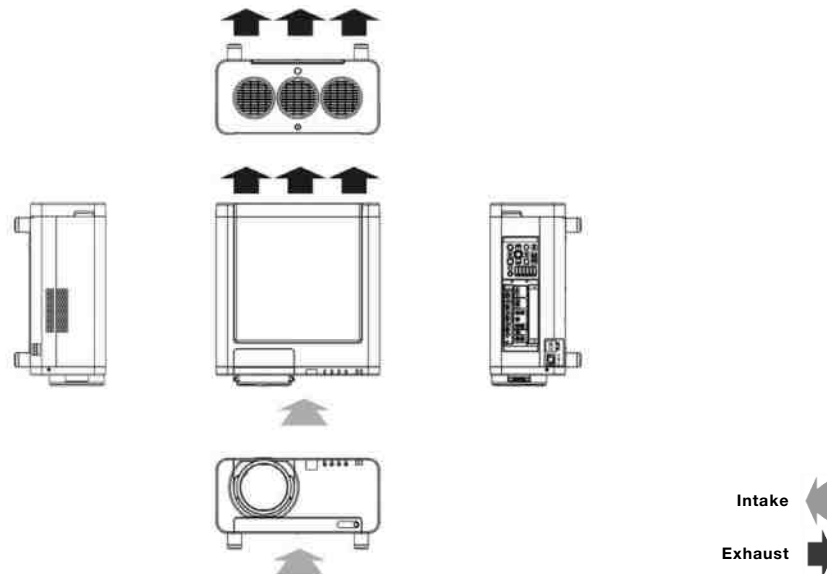

Operating the Projector Continuously

1. If the projector is to be operated continuously 24 hours, use the lamp relay mode. The projector cannot be operated continuously 24 hours in quad-lamp mode. Allow a minimum of two hours per day of non-operation time if the projector is to be operated continuously more than 22 hours.
2. The lamp replacement cycle duration becomes shorter if the projector is operated repeatedly for short periods.

Weights and dimensions shown are approximate. Specifications are subject to change without notice. This product may be subject to export control regulations. DLP and the DLP logo are trademarks of Texas Instruments. UHM is a trademark of Matsushita Electric. The PJLink is an application trademark in Japan, the United States, and other countries and regions or registered trademarks. All other trademarks are the property of their respective trademark owners.